



**DESIGN AND
CONSTRUCTION
STANDARD DRAWINGS
2017**

DEPARTMENT OF ENGINEERING AND CAPITAL PROJECTS

SHEET INDEX

<i>STD.</i>	<i>SHT.</i>	<i>TITLE</i>	<i>PREV. STD.</i>
<i>DRAINAGE – (DRN)</i>			
<i>DRN-01</i>		<i>2-YEAR, 6-HOUR PRECIPITATION</i>	<i>CVD DR02</i>
<i>DRN-02</i>		<i>10-YEAR, 6-HOUR PRECIPITATION</i>	<i>CVD DR03</i>
<i>DRN-03</i>		<i>50-YEAR, 6-HOUR PRECIPITATION</i>	<i>CVD DR04</i>
<i>DRN-04</i>		<i>100-YEAR, 6-HOUR PRECIPITATION</i>	<i>CVD DR05</i>
<i>DRN-05</i>		<i>STREET DRAINAGE 36'-WIDE STREETS</i>	<i>CVD DR08</i>
<i>DRN-06</i>		<i>STREET DRAINAGE – 40' & 64' WIDE STREETS</i>	<i>CVD DR09</i>
<i>DRN-07</i>		<i>INLET DESIGN – LENGTH OF INLET</i>	<i>CVD DR06</i>
<i>DRN-08</i>		<i>INLET DESIGN – PARTIAL INTERCEPTION OF GUTTER FLOW</i>	<i>CVD DR07</i>
<i>DRN-09</i>	<i>1</i>	<i>CURB INLET OPENING</i>	<i>CVCS 45</i>
<i>DRN-09</i>	<i>2</i>	<i>CURB INLET CURB HEIGHT AND PAVEMENT TRANSITION</i>	<i>CVCS 45</i>
<i>DRN-10</i>	<i>1</i>	<i>SIDEWALK UNDERDRAIN CURB OUTLET DETAIL</i>	<i>CVCS 17</i>
<i>DRN-11</i>		<i>STORM DRAIN STENCIL</i>	<i>CVCS 24</i>
<i>DRN-12</i>	<i>1</i>	<i>LANDSCAPE MEDIAN DRAIN</i>	<i>CVCS 5</i>
<i>DRN-12</i>	<i>2</i>	<i>LANDSCAPE MEDIAN DRAIN SECTIONS</i>	<i>CVCS 5</i>
<i>GRADING – (GRD)</i>			
<i>GRD-01</i>		<i>VERTICAL SLOPE ROUNDING</i>	<i>CVD GR02</i>
<i>GRD-02</i>		<i>HORIZONTAL SLOPE ROUNDING</i>	<i>CVD GR03</i>
<i>GRD-03</i>		<i>DRIVEWAYS VERTICAL DESIGN</i>	<i>CVD GR04</i>
<i>GRD-04</i>		<i>DRIVEWAYS MINIMUM GARAGE SETBACK</i>	<i>CVD GR05</i>
<i>GRD-05</i>	<i>1</i>	<i>RETAINING WALL REQUIREMENTS PUBLICATION OUTLINES</i>	<i>CVCS 30</i>
<i>GRD-05</i>	<i>2</i>	<i>RETAINING WALL REQUIREMENTS PUBLICATION OUTLINES</i>	<i>CVCS 30</i>
<i>GRD-05</i>	<i>3</i>	<i>RETAINING WALL REQUIREMENTS PUBLICATION OUTLINES</i>	<i>CVCS 30</i>
<i>GRD-05</i>	<i>4</i>	<i>RETAINING WALL REQUIREMENTS PUBLICATION OUTLINES</i>	<i>CVCS 30</i>
<i>GRD-05</i>	<i>5</i>	<i>RETAINING WALL REQUIREMENTS PUBLICATION OUTLINES</i>	<i>CVCS 30</i>
<i>GRD-05</i>	<i>6</i>	<i>RETAINING WALL REQUIREMENTS PUBLICATION OUTLINES</i>	<i>CVCS 30</i>
<i>GRD-05</i>	<i>7</i>	<i>RETAINING WALL TYPE I</i>	<i>CVCS 31</i>
<i>GRD-05</i>	<i>8</i>	<i>RETAINING WALL TYPE II</i>	<i>CVCS 32</i>
<i>GRD-05</i>	<i>9</i>	<i>RETAINING WALL, CAP, KEY, & DRAINAGE DETAILS</i>	<i>CVCS 33</i>
<i>GRD-05</i>	<i>10</i>	<i>RETAINING WALL STEP FOOTING & JOINT DETAILS</i>	<i>CVCS 34</i>
<i>GRD-05</i>	<i>11</i>	<i>TABLE FOR VARIABLE HEEL, LEVEL BACKFILL, & 2 TO 1 SLOPE</i>	<i>CVCS 35</i>
<i>GRD-05</i>	<i>12</i>	<i>TABLE FOR VAR. HEEL, 1.5-1 SLOPE, 250 PSF, & SURCHARGE</i>	<i>CVCS 36</i>
<i>GRD-05</i>	<i>13</i>	<i>TABLE FOR 6-IN HEEL, LEVEL BACKFILL, & 2 TO 1 SLOPE</i>	<i>CVCS 37</i>
<i>GRD-05</i>	<i>14</i>	<i>TABLE FOR 6-IN HEEL, 1.5 TO 1 SLOPE, 250 PSF, & SURCHARGE</i>	<i>CVCS 38</i>
<i>GRD-05</i>	<i>15</i>	<i>TABLE FOR 2-IN HEEL, LEVEL BACKFILL, & 2 TO 1 SLOPE</i>	<i>CVCS 39</i>
<i>GRD-05</i>	<i>16</i>	<i>TABLE FOR 2-IN HEEL, 1.5 TO 1 SLOPE, 250 PSF & SURCHARGE</i>	<i>CVCS 40</i>
<i>GRD-06</i>		<i>GRADED SLOPES</i>	<i>CVD GR01</i>



SHEET INDEX

(CONTINUED)

STD.	SHT.	TITLE	PREV. STD.
<i>GENERAL SURFACE IMPROVEMENTS – (GSI)</i>			
<i>GSI-01</i>	1	<i>DRIVEWAY WITH MONOLITHIC CURB, GUTTER, AND SIDEWALK</i>	<i>CVCS 1</i>
<i>GSI-01</i>	2	<i>DRIVEWAY WITH NON-CONTIGUOUS SIDEWALK</i>	<i>CVCS 1</i>
<i>GSI-01</i>	3	<i>DRIVEWAY NOTES</i>	<i>CVCS 1</i>
<i>GSI-02</i>	1	<i>CROSS GUTTER</i>	<i>CVCS 2</i>
<i>GSI-02</i>	2	<i>CROSS GUTTER DOWEL CONNECTIONS</i>	<i>CVCS 2</i>
<i>GSI-03</i>	1	<i>TRENCH BACKFILL TYPE I AND J</i>	<i>CVCS 3</i>
<i>GSI-03</i>	2	<i>TRENCH BACKFILL NOTES</i>	<i>CVCS 4</i>
<i>GSI-03</i>	3	<i>MORATORIUM ROADWAY TRENCH RESURFACING</i>	
<i>GSI-04</i>		<i>CURB & SIDEWALK JOINT DETAILS</i>	<i>CVCS 41</i>
<i>GSI-05</i>		<i>SIDEWALK THICK EDGE AT DRIVEWAY</i>	<i>CVCS 42</i>
<i>GSI-06</i>		<i>MANHOLE ADJUSTMENT</i>	<i>CVCS 48</i>
<i>GSI-7</i>		<i>STAMPED CONCRETE</i>	<i>CVCS 43</i>
<i>GSI-08</i>	1	<i>CURB RAMP TYPES A & B – NEW CONSTRUCTION</i>	<i>CVCS 25</i>
<i>GSI-08</i>	2	<i>CURB RAMP TYPE A1 B1 – EXISTING SIDEWALK</i>	<i>CVCS 26</i>
<i>GSI-08</i>	3	<i>CURB RAMP TYPE C</i>	<i>CVCS 27</i>
<i>GSI-08</i>	4	<i>CURB RAMP TYPE D</i>	<i>CVCS 28</i>
<i>GSI-08</i>	5	<i>CURB RAMP NOTES</i>	<i>CVCS 29</i>
<i>GSI-08</i>	6	<i>TRUNCATED DOMES</i>	<i>CVCS 29</i>
<i>MISCELLANEOUS – (MSC)</i>			
<i>MSC-01</i>		<i>SURVEY MONUMENT (LOCATED IN STREET)</i>	<i>CVCS 15</i>
<i>MSC-02</i>		<i>POST & RAIL FENCE</i>	<i>CVCS 16</i>
<i>MSC-03</i>		<i>CHAIN LINK TENNIS COURT FENCE</i>	<i>CVCS 13</i>
<i>MSC-04</i>		<i>BUS STOP & IRRIGATION PIPE SLEEVE</i>	<i>CVCS 44</i>
<i>MSC-05</i>		<i>MAILBOX INSTALLATION</i>	<i>CVCS 46</i>
<i>ROADWAY – (RWY)</i>			
<i>RWY-01</i>	1	<i>6-LANE PRIME STREET SECTION WITH CONTIGUOUS SIDEWALK</i>	<i>CVD ST01</i>
<i>RWY-01</i>	2	<i>4-LANE MAJOR AND COLLECTOR STREET WITH CONTIGUOUS SIDEWALK</i>	<i>CVD ST02</i>
<i>RWY-01</i>	3	<i>2-LANE COLLECTOR & RESIDENTIAL STREET WITH CONTIGUOUS SIDEWALK</i>	<i>CVD ST03</i>
<i>RWY-01</i>	4	<i>2-LANE RESIDENTIAL & INDUSTRIAL STREET WITH CONTIGUOUS SIDEWALK</i>	<i>CVD ST04</i>
<i>RWY-02</i>	1	<i>MAJOR & COLLECTOR STREETS WITH NON-CONTIGUOUS SIDEWALK</i>	<i>CVD ST21</i>
<i>RWY-02</i>	2	<i>COLLECTOR & RESIDENTIAL STREETS WITH NON-CONTIGUOUS SIDEWALK</i>	<i>CVD ST22</i>
<i>RWY-02</i>	3	<i>RESIDENTIAL & INDUSTRIAL STREETS WITH NON-CONTIGUOUS SIDEWALK</i>	<i>CVD ST23</i>
<i>RWY-03</i>	1	<i>OTAY RANCH – EXPRESSWAY, PRIME & MAJOR STREET SECTIONS</i>	<i>CVD ST31</i>
<i>RWY-03</i>	2	<i>OTAY RANCH – VILLAGE ENTRY STREET SECTIONS</i>	<i>CVD ST32</i>
<i>RWY-03</i>	3	<i>OTAY RANCH – SECONDARY VILLAGE ENTRY STREET SECTIONS</i>	<i>CVD ST33</i>
<i>RWY-03</i>	4	<i>OTAY RANCH – PROMENADE STREET SECTIONS</i>	<i>CVD ST34</i>



SHEET INDEX

(CONTINUED)

STD.	SHT.	TITLE	PREV. STD.
<i>ROADWAY CONTINUED – (RWY)</i>			
<i>RWY-03</i>	<i>5</i>	<i>OTAY RANCH – PKWY, RESIDENTIAL, & INDUSTRIAL ST SECTIONS</i>	<i>CVD ST35</i>
<i>RWY-04</i>	<i>1</i>	<i>6-LANE PRIME INTERSECTION STANDARDS</i>	<i>CVD ST12</i>
<i>RWY-04</i>	<i>2</i>	<i>6-LANE MAJOR INTERSECTION STANDARDS</i>	<i>CVD ST13</i>
<i>RWY-04</i>	<i>3</i>	<i>6-LANE MAJOR INTERSECTION STANDARDS 2</i>	<i>CVD ST14</i>
<i>RWY-04</i>	<i>4</i>	<i>4-LANE MAJOR INTERSECTION STANDARDS</i>	<i>CVD ST15</i>
<i>RWY-04</i>	<i>5</i>	<i>4-LANE MAJOR & COLLECTOR INTERSECTION STANDARDS</i>	<i>CVD ST16</i>
<i>RWY-04</i>	<i>6</i>	<i>OTAY RANCH – VILLAGE INTERSECTION STANDARDS</i>	<i>CVD ST36</i>
<i>RWY-05</i>	<i>1</i>	<i>SIGHT DISTANCE REQUIREMENTS</i>	<i>CVD TR07</i>
<i>RWY-05</i>	<i>2</i>	<i>SIGHT DISTANCE REQUIREMENTS ADDITIONAL NOTES</i>	<i>CVD TR07</i>
<i>RWY-05</i>	<i>3</i>	<i>SIGHT DISTANCE REQUIREMENTS FOR STREETS 40’ OR LESS</i>	<i>CVD TR08</i>
<i>RWY-06</i>	<i>1</i>	<i>TURN LANE REQUIREMENTS</i>	<i>CVD ST11</i>
<i>RWY-06</i>	<i>2</i>	<i>OTAY RANCH – TURN LANE REQUIREMENTS</i>	<i>CVD ST37</i>
<i>RWY-07</i>		<i>KNUCKLES TYPE I AND TYPE II</i>	<i>CVD ST05</i>
<i>RWY-08</i>		<i>CUL-DE-SAC</i>	<i>CVD ST06</i>
<i>RWY-09</i>		<i>LOCATION OF UNDERGROUND UTILITIES IN STREET</i>	<i>CVD ST07</i>
<i>SEWER – (SWR)</i>			
<i>SWR-01</i>		<i>PEAK TO AVERAGE SEWER FLOW</i>	<i>CVD SW01</i>
<i>SWR-02</i>		<i>DEEP SEWER CONNECTION</i>	<i>CVCS 14</i>
<i>SWR-03</i>		<i>DEEP CUT HOUSE CONNECTION SEWER LATERAL</i>	<i>CVCS 18</i>
<i>SWR-04</i>		<i>SEWER LATERAL IN LANDSCAPED AREAS</i>	<i>CVCS 20</i>
<i>SWR-05</i>		<i>SEWER LATERAL IN PCC DRIVEWAY</i>	<i>CVCS 21</i>
<i>SWR-06</i>		<i>SEWER LATERAL IN LANDSCAPE SW & DRY UTILITIES IN R.O.W.</i>	<i>CVCS 22</i>
<i>SWR-07</i>		<i>SEWER LATERAL IN PCC DWY – SW & DRY UTILITIES IN R.O.W.</i>	<i>CVCS 23</i>
<i>SWR-08</i>		<i>SEWER MAIN REPAIR DETAILS</i>	<i>CVCS 49</i>
<i>TRAFFIC – (TRF)</i>			
<i>TRF-01</i>		<i>TRAFFIC SIGNAL STANDARD LOCATIONS</i>	<i>CVD TR01</i>
<i>TRF-02</i>		<i>TYPICAL SIGN POST PLACEMENT</i>	<i>CVD TR02</i>
<i>TRF-03</i>		<i>STREET LIGHT LOCATIONS</i>	<i>CVD TR04</i>
<i>TRF-04</i>		<i>TYPICAL SIDEWALK AND CROSSWALK LOCATIONS</i>	<i>CVD TR05</i>
<i>TRF-05</i>		<i>SIGNAL HEAD MOUNTING BRACKET AND MAST ARM INSTALLATION</i>	<i>CVCS 8</i>
<i>TRF-06</i>		<i>EVPE DETECTOR</i>	<i>CVCS 12</i>
<i>TRF-07</i>	<i>1</i>	<i>STREET NAME SIGNS</i>	<i>CVD TR06A</i>
<i>TRF-07</i>	<i>2</i>	<i>STREET NAME SIGNS DETAILS</i>	<i>CVD TR06B</i>
<i>TRF-07</i>	<i>3</i>	<i>OVERHEAD STREET NAME SIGNS</i>	
<i>TRF-07</i>	<i>4</i>	<i>OVERHEAD STREET NAME SIGN DETAILS</i>	
<i>TRF-07</i>	<i>5</i>	<i>OVERHEAD STREET NAME SIGN ABBREVIATIONS</i>	



SHEET INDEX

(CONTINUED)

<i>STD.</i>	<i>SHT.</i>	<i>TITLE</i>	<i>PREV. STD.</i>
<i>TRAFFIC CONTINUED – (TRF)</i>			
<i>TRF-08</i>	<i>1</i>	<i>STREET LIGHTING STANDARD</i>	<i>CVCS 6</i>
<i>TRF-08</i>	<i>2</i>	<i>STREET LIGHT STANDARD FOUNDATION DETAIL</i>	<i>CVCS 7</i>
<i>TRF-08</i>	<i>3</i>	<i>STREET LIGHTING STANDARD ELECTRICAL DETAILS</i>	<i>CVCS 9</i>
<i>TRF-09</i>		<i>PULL BOXES</i>	<i>CVCS 11</i>
<i>TRF-09</i>		<i>STREET LIGHT & TRAFFIC SIGNAL CONDUIT TRENCH</i>	<i>CVCS 10</i>
<i>TRF-10</i>	<i>1</i>	<i>BREAK-AWAY SIGN POST</i>	<i>CVD TR03</i>
<i>TRF-10</i>	<i>2</i>	<i>BREAKAWAY POST ON MEDIAN</i>	<i>CVCS 47</i>
<i>TRF-11</i>		<i>LADDER CROSSWALK MARKINGS LAYOUTS AND NOTES</i>	

DESCRIPTION	CITY STANDARD DRAWING	LEGEND	
		PROPOSED	EXISTING (GHOSTED)
CONTROLLER			
TRAFFIC SIGNAL WITH MASTARM, SAFETY LIGHT; SIGNAL INDICATION, BACK PLATE AND INTERNALLY ILLUMINATED STREET NAME SIGN.			
FLASHING BEACON, ONE WAY			
INDUCTIVE LOOP DETECTOR			
ELECTRICAL CONDUIT			
EMERGENCY VEHICLE PRE-EMPTION EQUIPMENT (E.V.P.E.)			
METER PEDESTAL			
SERVICE POINT			
STREET LIGHTS	TRF-08 TRF-08		
OVERHEAD CONDUCTOR			
PEDESTRIAN PUSH BUTTON ON SPECIAL PUSH BUTTON POST	TRF-08		
POWER POLE			
PULL BOX			
INDUCTIVE LOOP DETECTOR PULL BOX AND STUB-OUT			
TELEPHONE POLE			
TRAFFIC SIGNAL WITH THREE LENS INDICATION AND BLACK PLATE (UNLESS OTHERWISE INDICATED)			
TRAFFIC SIGNAL WITH THREE INDICATION (GREEN ARROW) AND BLACK PLATE (UNLESS OTHERWISE INDICATED)			
WALK-WAIT PEDESTRIAN SIGNAL			

REVISION	BY	APPROVED	DATE
ORIGINAL	ARR		7/95
10/15/02	CVM	C. SWANSON	7/95
11/21/17	DPH	W. VALLE	11/17

CITY OF CHULA VISTA
ENGINEERING & CAPITAL PROJECTS
STANDARD DRAWING
SYMBOLS FOR TRAFFIC SIGNAL &
LIGHTING INSTALLATIONS





WILLIAM S. VALLE 11/21/2017
CITY ENGINEER
IV

DESCRIPTION	CITY STANDARD DRAWING	LEGEND (REMARKS IN PARENTHESES ARE EXPLANATORY ONLY.) NEW CONSTRUCTION SYMBOLS ARE SOLID. EXISTING CONSTRUCTION IS GHOSTED.
--------------------	--------------------------------------	---

BOUNDARIES & CENTERLINES:

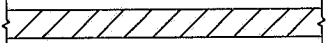
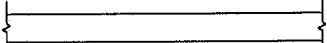
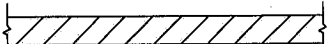
CITY BOUNDARY LINE		COUNTY OF SAN DIEGO (NO.3 PEN) CITY OF CHULA VISTA (IDENTIFY BOUNDARIES)
SUBDIVISION & RECORD OF SURVEY BOUNDARIES		(NO.2 PEN) (IDENTIFY SUBDIVISION OR R.O.S.)
PROPERTY LINES ALONG STREETS & ALLEYS		(NO.1 PEN)
LOT LINES BETWEEN LOTS, PARCEL & LOT SPLIT LINES		(NO.0 PEN)
EASEMENTS & SETBACK LINES		(NO.00 PEN) (INDICATE SIZE, TYPE & C OF EASEMENTS)
CENTERLINES		C

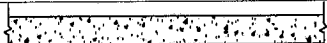
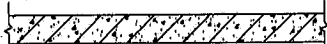
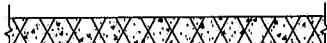
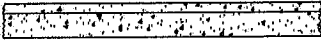
STREETS:

GRADING		
OVERLAY USING A.C. SURFACING ONLY SHOWN SHADED		
GRADING USING A.B. & A.C. SURFACING SHOWN SHADED		
OVERLAY USING A.B. & A.C. SURFACING SHOWN SHADED		
OVERLAY USING P.C.C. SURFACING		
GRADING USING P.C.C. SURFACING		
OVERLAY USING A.B. & P.C.C. SURFACING		
CURB & GUTTER		(INDICATE WHETHER 6" OR 8" & TRANSITION LOCATIONS)
CURB OR BERM OR DIKE		AC BERM OR PCC CURB (INDICATE TYPE & SIZE)
MONOLITHIC CURB, GUTTER, & SIDEWALK		
SIDEWALK		

REVISION	BY	APPROVED	DATE
ORIGINAL	ARR		8/69
11/05/01	CVM	C. SWANSON	11/02
11/21/17	DPH	W. VALLE	11/17

CITY OF CHULA VISTA
ENGINEERING & CAPITAL PROJECTS
STANDARD DRAWING

PROPERTY AND STREET SYMBOLS

William S. Valle
WILLIAM S. VALLE 11/21/2017
CITY ENGINEER

V

DESCRIPTION

CITY
STANDARD
DRAWING

LEGEND

(REMARKS IN PARENTHESES ARE EXPLANATORY ONLY.)
NEW CONSTRUCTION SYMBOLS ARE SOLID.
EXISTING CONSTRUCTION IS GHOSTED.

STREETS CONTINUED:

DRIVEWAY APPROACH	GSI-01	
ALLEY APPROACH	GSI-01 RADIUS	
CROSS GUTTER	GSI-02	
EDGE OF PAVEMENT		
RAILWAY TRACKS		
BARRICADE		
STREET SIGNS		

UTILITIES:

GAS MAIN		 (SHOW DIAMETER & TYPE)
GAS SERVICE CONNECTION		 (SHOW SIZE IF OTHER THAN 3/4")
GAS VALVE		
POWER LINES, OVERHEAD		 (SHOW NO. OF WIRES, VOLTAGE, ETC.)
POWER LINES UNDERGROUND		 (SHOW SIZE OF CONDUIT, VOLTAGE, ETC.)
POWER OR TELEPHONE MANHOLE		
POLE ANCHOR OR DEADMAN		
TELEPHONE LINES, OVERHEAD		 (SHOW NO. OF WIRES, ETC.)
TELEPHONE LINES, UNDERGROUND		 (SHOW SIZE, NO., CONDUIT, ETC.)

REVISION	BY	APPROVED	DATE
ORIGINAL	ARR		8/69
10/15/02	CVM	C. SWANSON	11/02
11/21/17	DPH	W. VALLE	11/17

CITY OF CHULA VISTA
ENGINEERING & CAPITAL PROJECTS
STANDARD DRAWING

STREET AND UTILITY SYMBOLS

William S. Valle
WILLIAM S. VALLE 11/21/2017
CITY ENGINEER

DESCRIPTION

CITY
STANDARD
DRAWING

LEGEND

(REMARKS IN PARENTHESES ARE EXPLANATORY ONLY.)
NEW CONSTRUCTION SYMBOLS ARE SOLID.
EXISTING CONSTRUCTION IS GHOSTED.

UTILITIES CONTINUED:

SEWER MAIN	
SEWER LATERALS	
SEWER MANHOLE	
SEWER PLUG	
SEWER MAIN CLEANOUT	
CONCRETE CRADLE	
CONCRETE ENCASEMENT	
WATER MAIN	
WATER SERVICE	
WATER (GATE) VALVE	
WATER METER	
BLOW OFF	
FIRE HYDRANT	

DRAINAGE:

STORM DRAIN OR CULVERT	
BOX CULVERT	
DRAINAGE CHANNEL OR DITCH	
HEADWALL OR ENDWALL	
CURB INLET	
STORM DRAIN CLEANOUT	

REVISION	BY	APPROVED	DATE
ORIGINAL	ARR		8/69
11/05/01	CVM	C. SWANSON	11/02
11/21/17	DPH	W. VALLE	11/17

CITY OF CHULA VISTA
ENGINEERING & CAPITAL PROJECTS
STANDARD DRAWING

William S. Valle
WILLIAM S. VALLE 11/21/2017
CITY ENGINEER

UTILITY AND DRAINAGE SYMBOLS

DESCRIPTION	CITY STANDARD DRAWING	LEGEND (REMARKS IN PARENTHESES ARE EXPLANATORY ONLY.) NEW CONSTRUCTION SYMBOLS ARE SOLID. EXISTING CONSTRUCTION IS GHOSTED.
-------------	-----------------------------	---

DRAINAGE CONTINUED:

CURB OUTLET		
PIPE COLLAR		

MONUMENTS:

BENCH MARK		(BM) (ELEV. _____)
SURVEY WELL MONUMENT		

MISCELLANEOUS:

TREES		(SHOW DIAMETER AT GROUND & TYPE OF TREE AS APPLICABLE)
FENCE (CHAIN LINK, WIRE)		6' C.L. 6' WIRE (SHOW HEIGHT)
WALL		8' CONC. BLOCK RET. (SHOW TYPE-CONC. BLOCK, BRICK, ETC., WHETHER FREE STANDING OR RETAINING & HEIGHT)
WOOD FENCE		6' WOOD FENCE (SHOW HEIGHT)

GRADING & LANDSCAPING:

ORIGINAL GROUND (PROFILE)		
FINISH ELEVATION		EL. = 180.25
EXISTING ELEVATION		EL. = (111.12)
EXISTING CONTOUR		
FINISH GRADE CONTOUR		
DAYLIGHT LINE		CUT FILL
SWALES & DIRECTION OF FLOW		
RIP RAP		
SLOPE PLANTING		
FILL SLOPE		TOP BOTTOM SHADE
CUT SLOPE		TOP BOTTOM

REVISION	BY	APPROVED	DATE
ORIGINAL	ARR		8/69
11/05/01	CVM	C. SWANSON	11/02
11/21/17	DPH	W. VALLE	11/17

CITY OF CHULA VISTA
ENGINEERING & CAPITAL PROJECTS
STANDARD DRAWING

SURVEY, GRADING &
MISCELLANEOUS SYMBOLS

William S. Valle
WILLIAM S. VALLE 11/21/2017
CITY ENGINEER

VIII

DRAINAGE

(DRN)



**DESIGN AND
CONSTRUCTION
STANDARD DRAWINGS
2017**

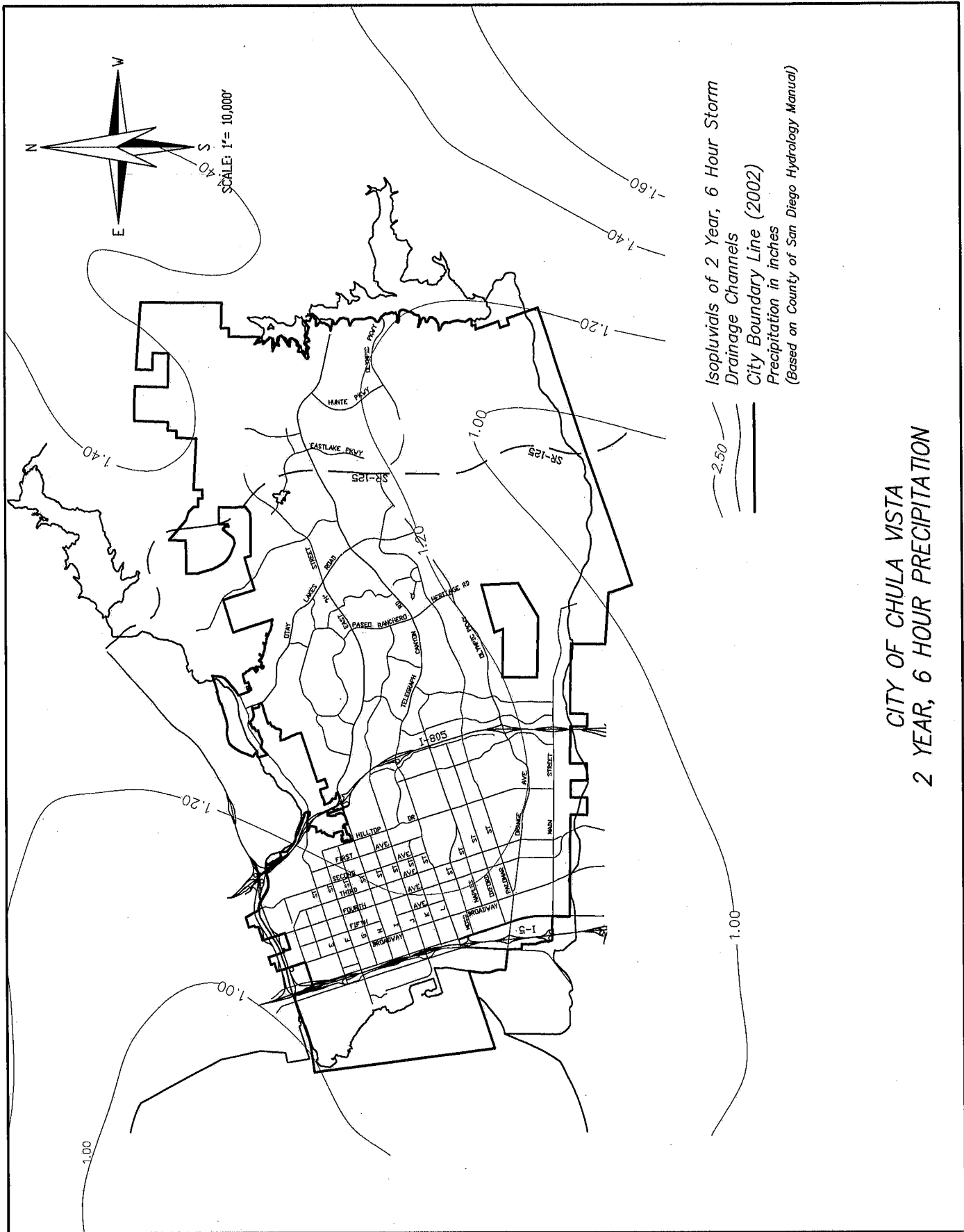

Isopleths of 2 Year, 6 Hour Storm
 Drainage Channels
 City Boundary Line (2002)
 Precipitation in inches
 (Based on County of San Diego Hydrology Manual)

CITY OF CHULA VISTA
 2 YEAR, 6 HOUR PRECIPITATION

REVISION	BY	APPROVED	DATE
ORIGINAL	CVM		01/02
REVISION	CVM	C. SWANSON	11/02
REVISION	DPH	W. VALLE	11/17

CITY OF CHULA VISTA
 ENGINEERING & CAPITAL PROJECTS
 STANDARD DRAWING
 2-YEAR, 6-HOUR PRECIPITATION

William S. Valle
 WILLIAM S. VALLE 11/21/2017
 CITY ENGINEER
 DRN-01

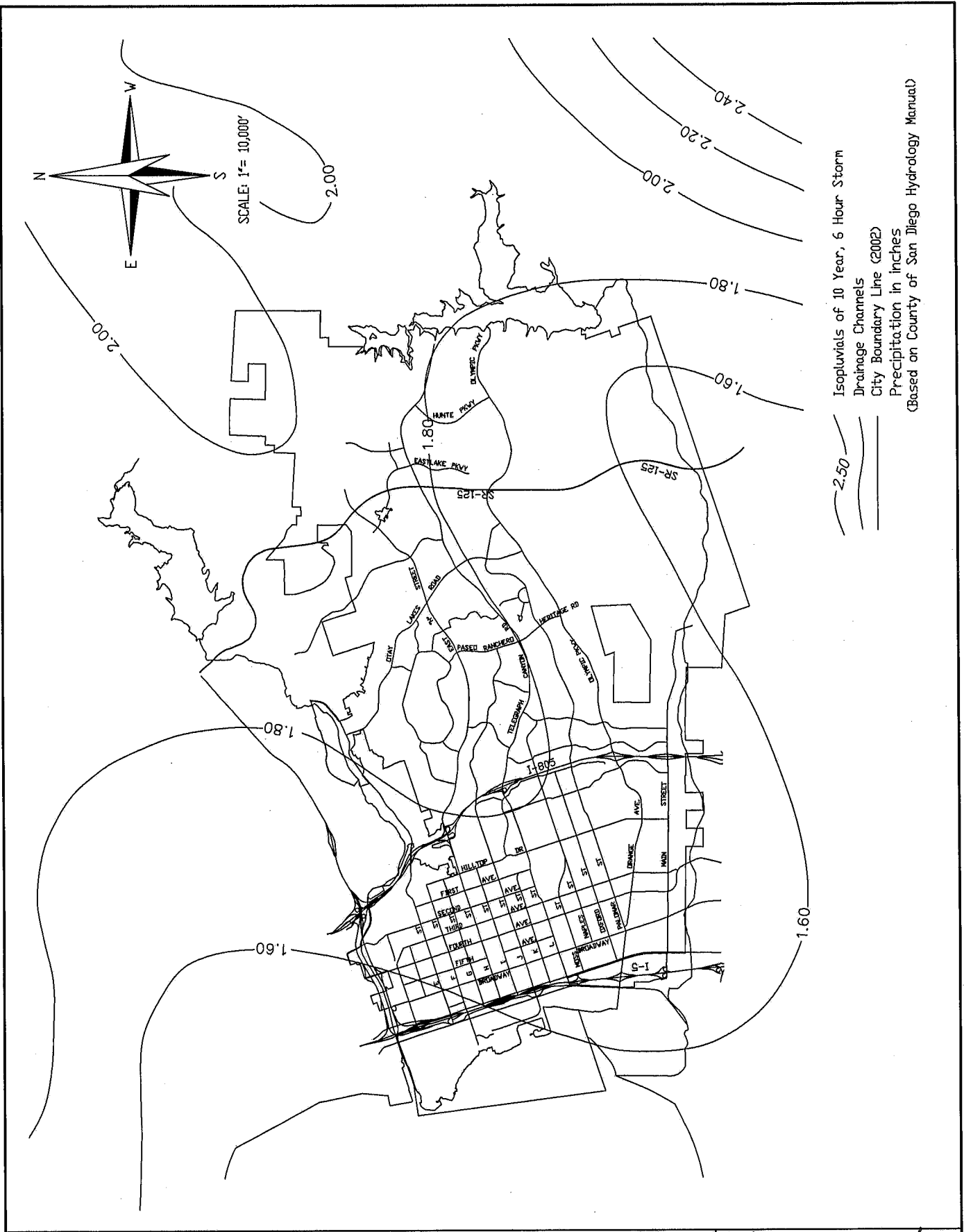

Isopleths of 10 Year, 6 Hour Storm
 Drainage Channels
 City Boundary Line (2002)
 Precipitation in inches
 (Based on County of San Diego Hydrology Manual)

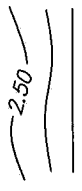

REVISION	BY	APPROVED	DATE
ORIGINAL	CVM		01/02
REVISION	CVM	C. SWANSON	11/02
REVISION	DPH	W. VALLE	11/17

CITY OF CHULA VISTA
 ENGINEERING & CAPITAL PROJECTS
 STANDARD DRAWING

10-YEAR, 6-HOUR PRECIPITATION

William S. Valle
 WILLIAM S. VALLE 11/21/2017
 CITY ENGINEER

DRN-02

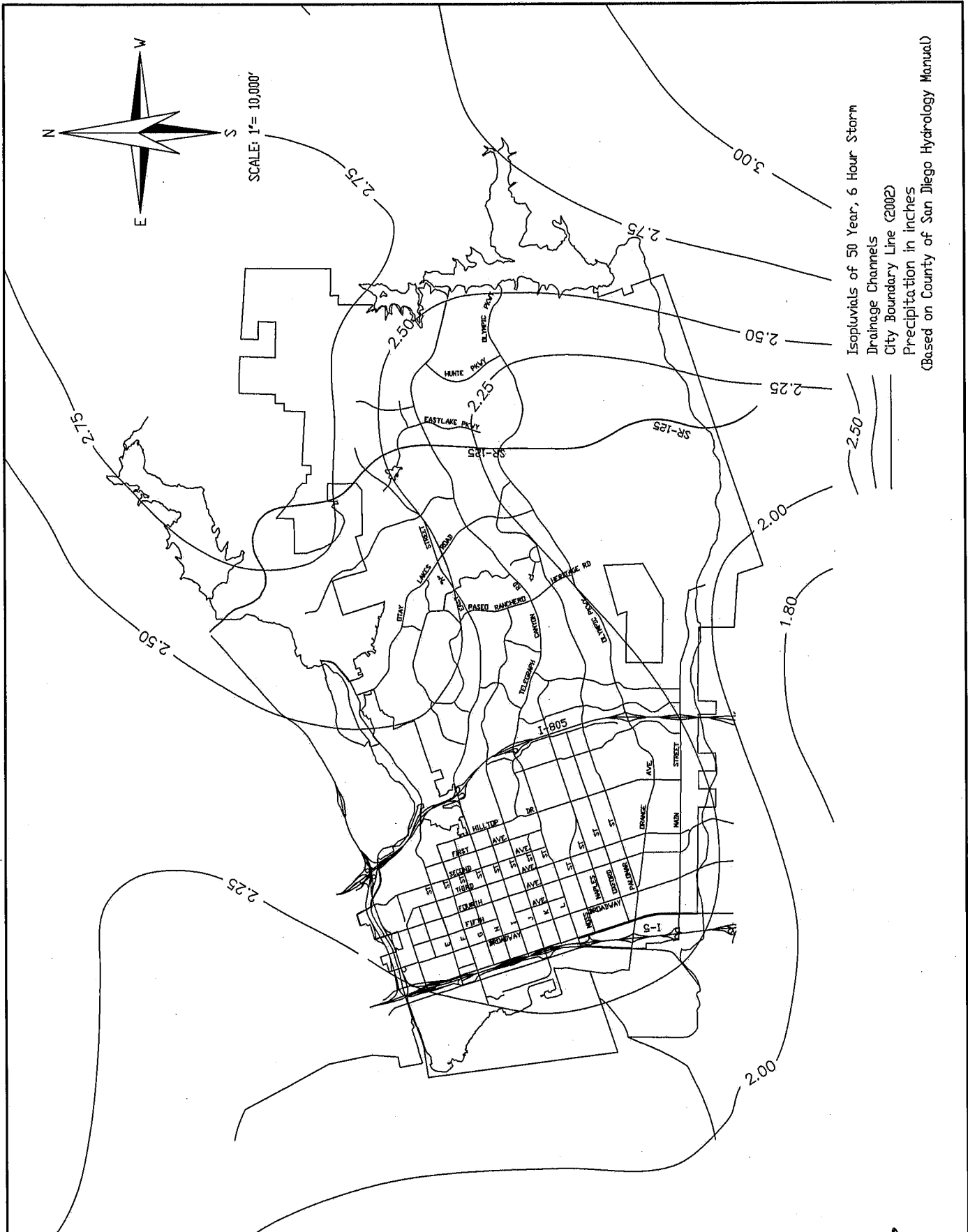

Isopleths of 50 Year, 6 Hour Storm
 Drainage Channels
 City Boundary Line (2002)
 Precipitation in inches
 (Based on County of San Diego Hydrology Manual)

REVISION	BY	APPROVED	DATE
ORIGINAL			01/02
REVISION	CVM	C. SWANSON	11/02
REVISION	DPH	W. VALLE	11/17

CITY OF CHULA VISTA
 ENGINEERING & CAPITAL PROJECTS
 STANDARD DRAWING

50-YEAR, 6-HOUR PRECIPITATION

William S. Valle
 WILLIAM S. VALLE 11/21/2017
 CITY ENGINEER

DRN-03

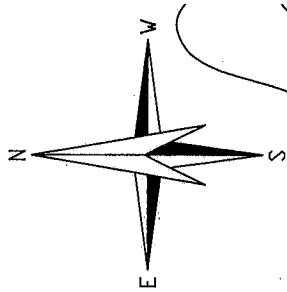

SCALE: 1" = 10,000'

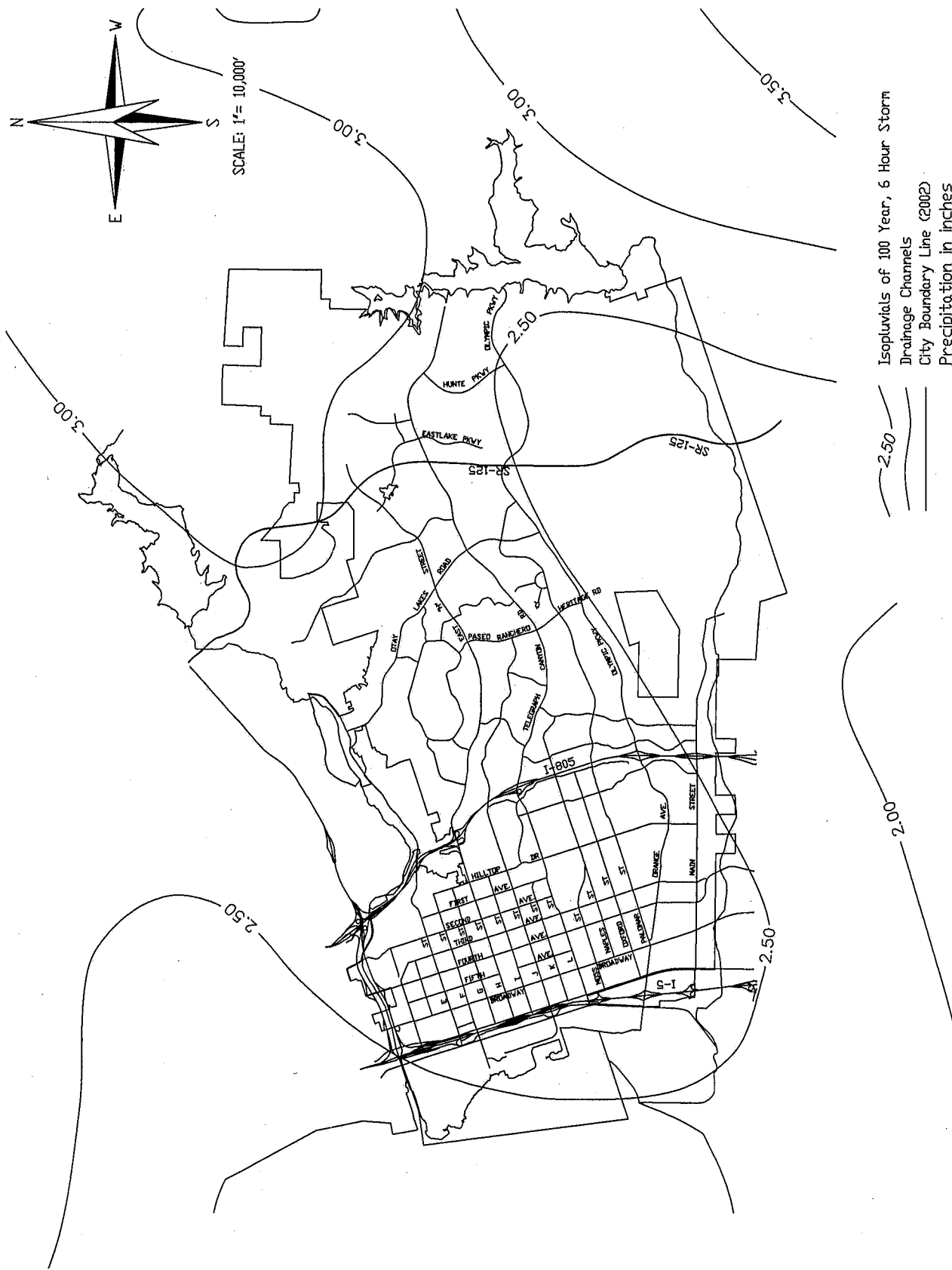

Isopleths of 100 Year, 6 Hour Storm
 Drainage Channels
 City Boundary Line (2002)
 Precipitation in inches
 (Based on County of San Diego Hydrology Manual)

REVISION	BY	APPROVED	DATE
ORIGINAL			01/02
REVISION	CVM	C. SWANSON	11/02
REVISION	DPH	W. VALLE	11/17

CITY OF CHULA VISTA
 ENGINEERING & CAPITAL PROJECTS
 STANDARD DRAWING

100-YEAR, 6-HOUR PRECIPITATION

William S. Valle
 WILLIAM S. VALLE 11/21/2017
 CITY ENGINEER

DRN-04

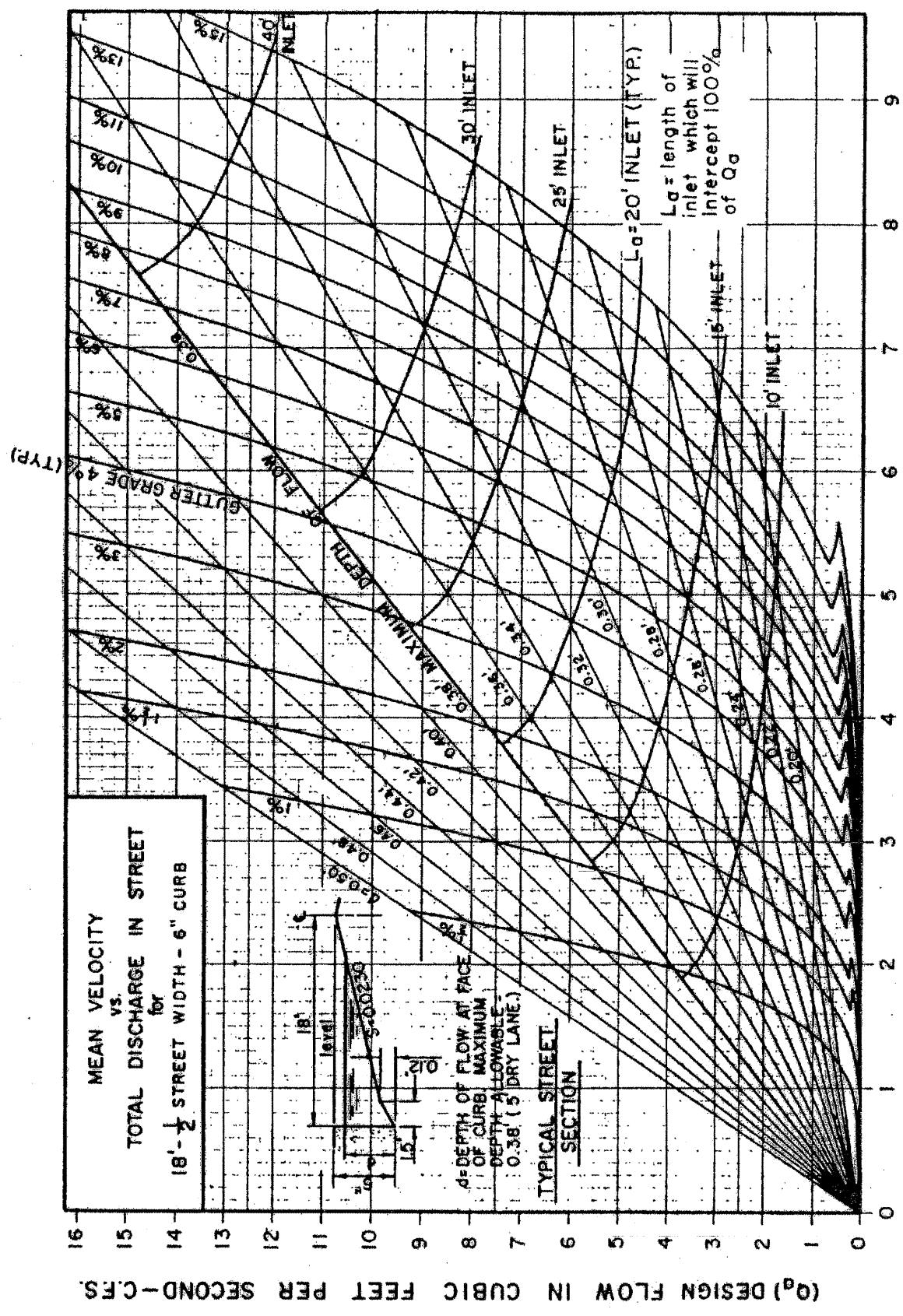

REVISION	BY	APPROVED	DATE
ORIGINAL	JWH		10/72
		C. SWANSON	11/02
REVISION	DPH	W. VALLE	11/17
REVISION	RAR	W. VALLE	04/19

CITY OF CHULA VISTA
 ENGINEERING & CAPITAL PROJECTS
 STANDARD DRAWING

STREET DRAINAGE 36'-WIDE
 STREETS

William S. Valle

WILLIAM S. VALLE 04/09/2019
 CITY ENGINEER

DRN-05

TO DETERMINE LENGTH OF INLET TO INTERCEPT 100% OF GUTTER FLOW

ITEM	UNITS	DESCRIPTION	HOW DETERMINED
Q_d	c.f.s.	AMOUNT OF FLOW IN GUTTER ON ONE SIDE OF STREET.	HYDROLOGY STUDY OF AREA.
d	ft.	DEPTH OF FLOW AT FACE OF CURB.(NOT CONSIDERING INLET DEPRESSION)	SEE CVD-DR06 OR CVD-DR07 (INTERSECTION OF Q_d LINE AND GUTTER GRADE LINE WILL FALL BETWEEN d LINES. INTERPOLATE FOR VALUES.)
L_d	ft.	LENGTH OF INLET WHICH WILL INTERCEPT 100% OF Q_d AT GIVEN GUTTER GRADE.	CVD-DR06 AND CVD-DR07 (INTERSECTION OF Q_d LINE AND GUTTER GRADE LINE WILL FALL BETWEEN d LINES. INTERPOLATE FOR VALUES.)

TO DETERMINE LENGTH OF INLET TO INTERCEPT A PORTION OF GUTTER FLOW

(THIS METHOD TRIES DIFFERENT LENGTHS OF INLETS TO DETERMINE HOW MUCH FLOW WILL BE INTERCEPTED BY EACH LENGTH INLET AND HOW MUCH FLOW WILL CONTINUE PAST INLET. FIRST DETERMINE Q_d , d AND L_d AS ABOVE.)

ITEM	UNITS	DESCRIPTION	HOW DETERMINED
L	ft.	LENGTH OF PROPOSED INLET	SELECT TRIAL LENGTH
L/L_d		RATIO OF L TO L_d	DIVIDE L BY L_d
a	ft.	AMOUNT FLOW LINE OF GUTTER IS DEPRESSED AT INLET.	STD. DWG. OF INLET BEING CONSIDERED FOR USE.
a/d		RATIO OF a TO d	DIVIDE a BY d
Q	c.f.s.	FLOW INTERCEPTED BY INLET OF LENGTH L.	CVD-DR05 (INTERSECTION OF L/L_d LINE AND a/d LINE WILL FALL BETWEEN Q/Q_d LINE. INTERPOLATE FOR VALUES $Q = Q_d \times Q/Q_d$)
$Q_d - Q$	c.f.s.	FLOW CONTINUING PAST INLET.	SUBTRACT Q FROM Q_d

NOTE:

DRN-07 OR DRN-08 MAY ALSO BE USED BEGINNING WITH A SELECTED Q TO DETERMINE L.

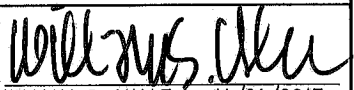
REVISION	BY	APPROVED	DATE	CITY OF CHULA VISTA ENGINEERING & CAPITAL PROJECTS STANDARD DRAWING	 WILLIAM S. VALLE CITY ENGINEER
ORIGINAL			08/78		
REVISION	CM	C. SWANSON	11/02		
REVISION	DPH	W. VALLE	11/17	INLET DESIGN - LENGTH OF INLET	11/21/2017
					DRN-07

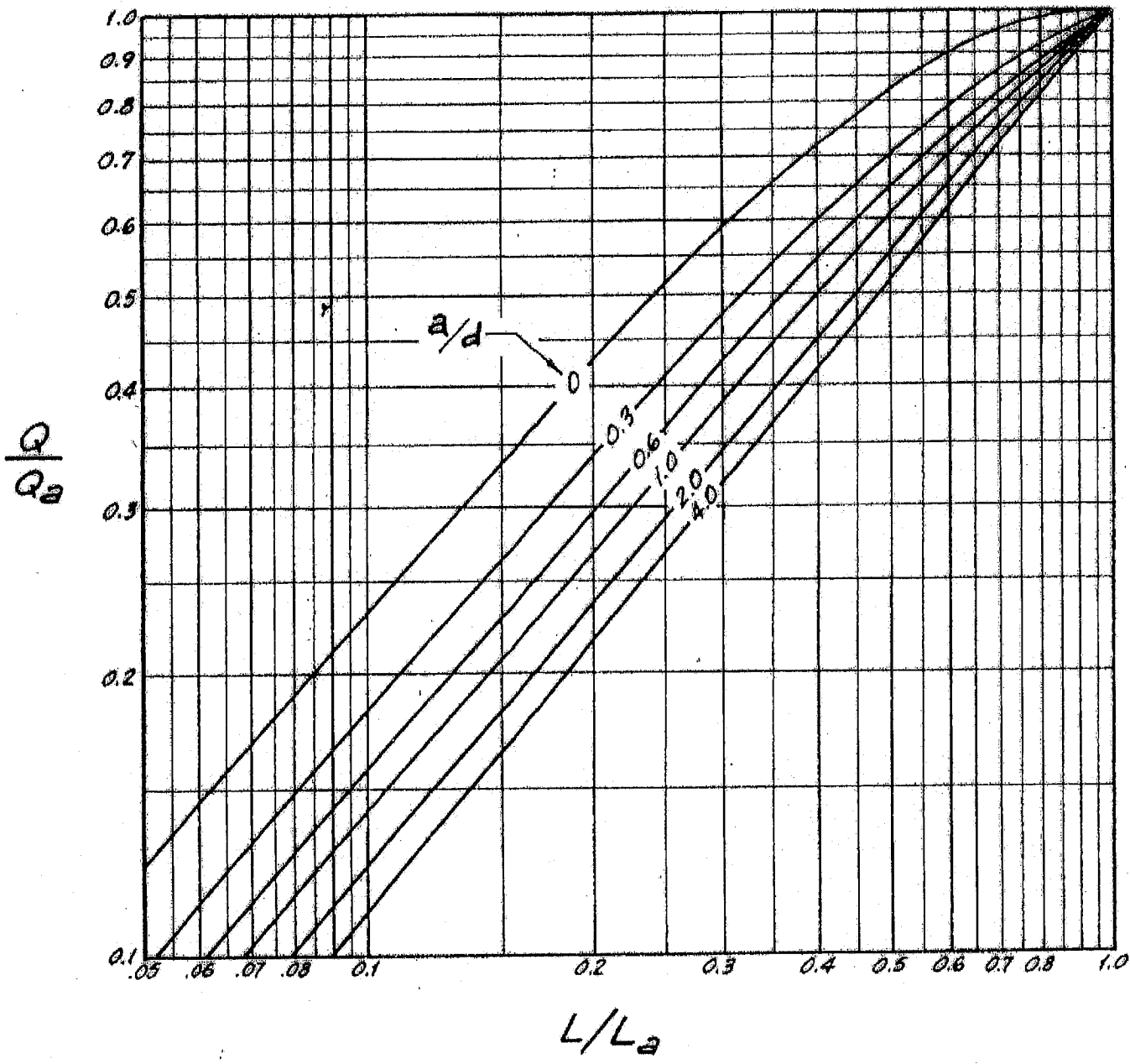

NOTE: SEE VIII FOR IDENTIFICATION OF SYMBOLS

REVISION	BY	APPROVED	DATE
ORIGINAL	JWH		11/72
		C. SWANSON	11/02
REVISION	DPH	W. VALLE	11/17

CITY OF CHULA VISTA
 ENGINEERING & CAPITAL PROJECTS
 STANDARD DRAWING

INLET DESIGN – PARTIAL
 INTERCEPTION OF GUTTER FLOW

William S. Valle
 WILLIAM S. VALLE 11/21/2017
 CITY ENGINEER

DRN-08

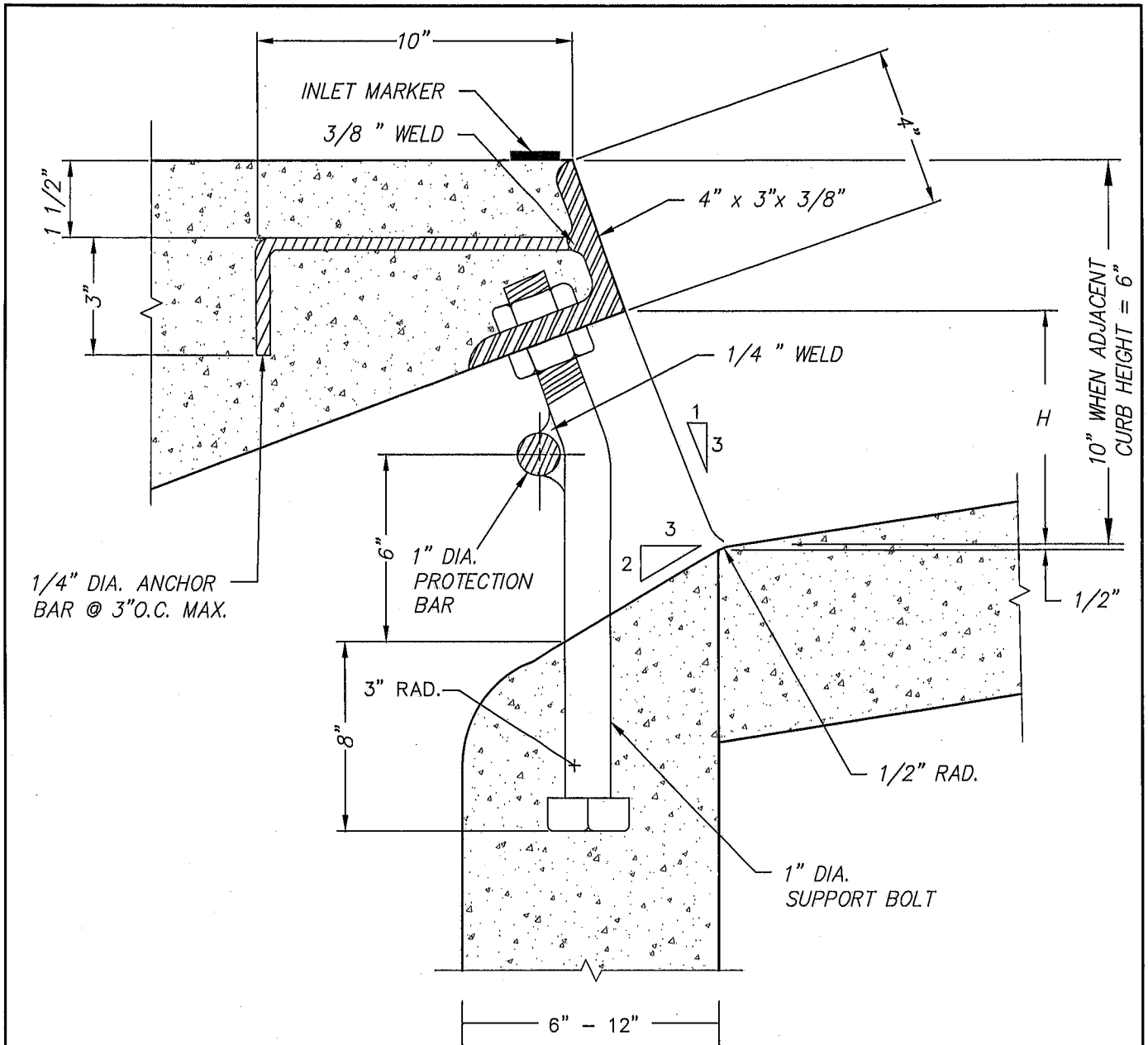

NOTES:

1. FACE ANGLE SHALL BE CAST INTO STRUCTURE CONTINUOUS FOR THE FULL LENGTH "L".
2. EXPOSED METAL PARTS SHALL BE HOT-DIPPED GALVANIZED AFTER FABRICATION.
3. WHEN CURB INLET OPENING HEIGHT (H) EXCEEDS 8", INSTALL 1" DIA. STEEL PROTECTION BAR. STEEL PROTECTION BAR SHALL BE EMBEDDED 8" INTO CURB INLET.
4. INSTALL ADDITIONAL BARS AT 3 1/2" CLEAR SPACING ABOVE FIRST BAR WHEN OPENING EXCEEDS 16".
5. WHEN CURB INLET OPENING LENGTH EXCEEDS 8', INSTALL 1" DIA. STEEL SUPPORT BOLTS, SPACED AT NOT MORE THAN 5' OC.

SHEET 1 OF 2

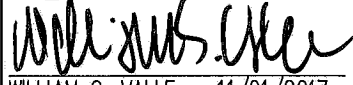
REVISION	BY	APPROVED	DATE	CITY OF CHULA VISTA ENGINEERING & CAPITAL PROJECTS STANDARD DRAWING	 WILLIAM S. VALLE CITY ENGINEER
ORIGINAL	DPH	W. VALLE	11/17		
				CURB INLET OPENING	DRN-09

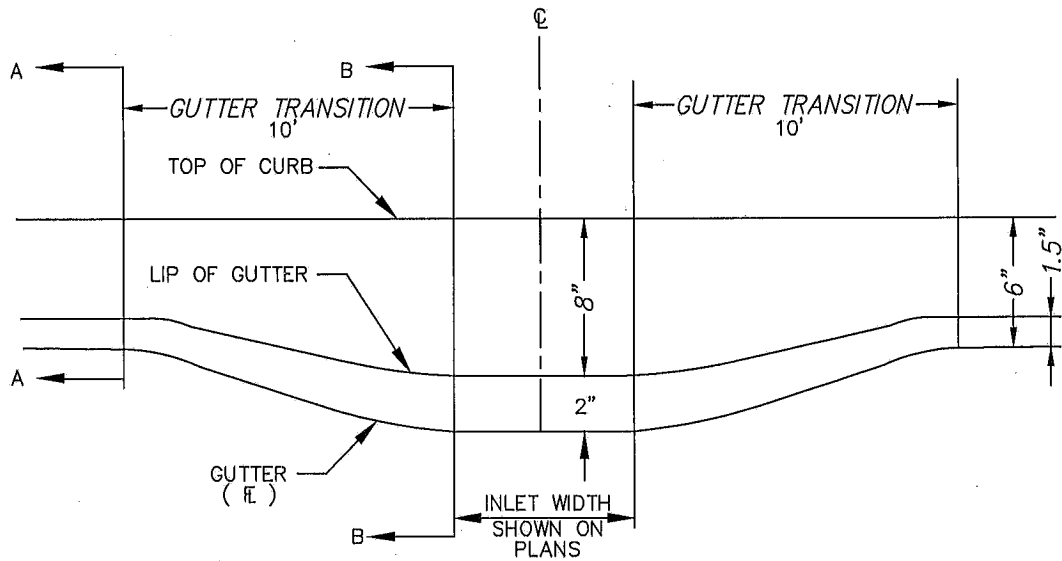
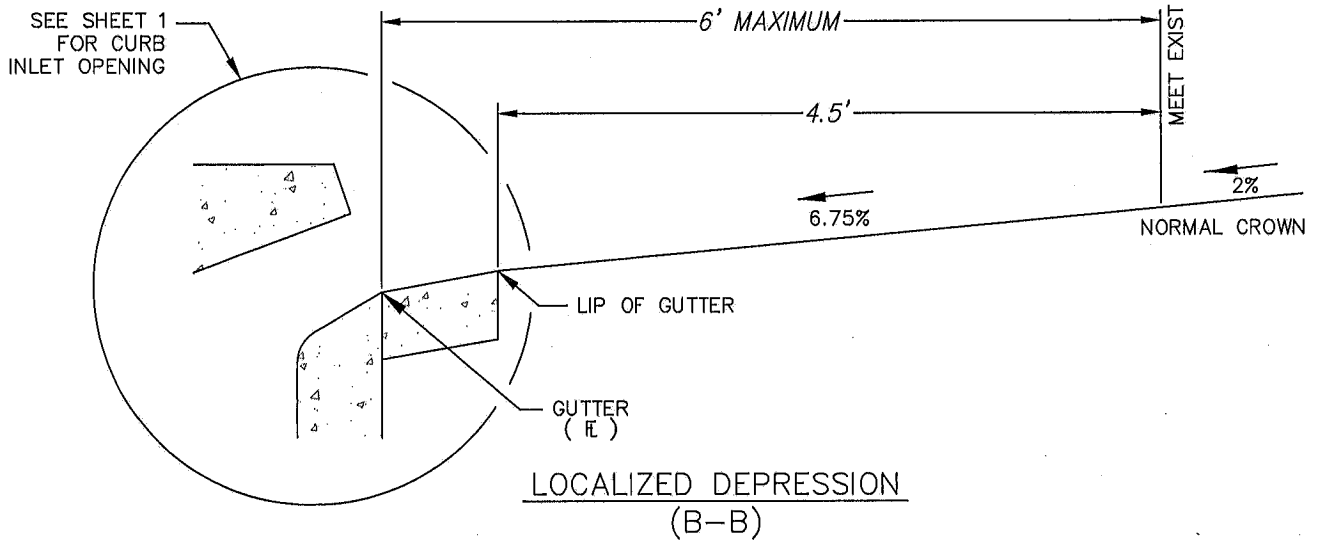
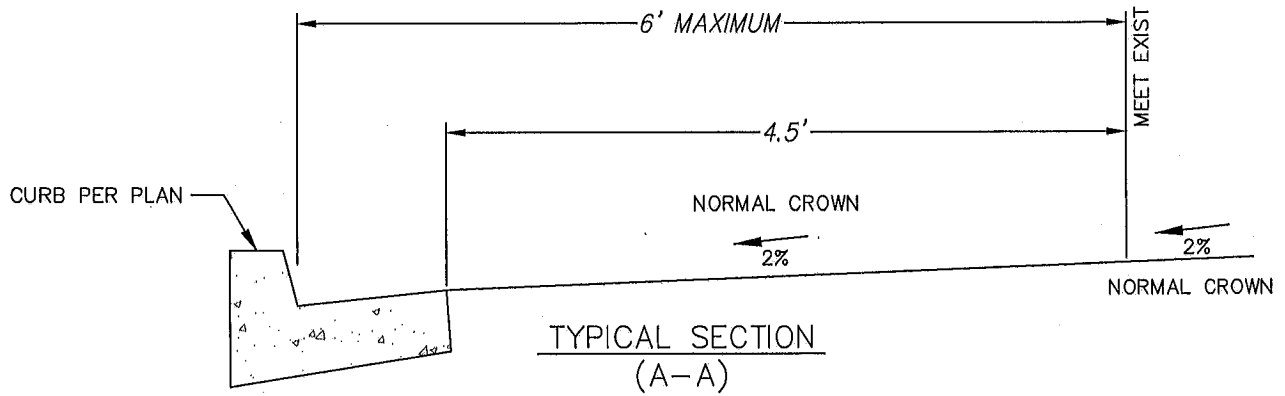

SHEET 2 OF 2

REVISION	BY	APPROVED	DATE	CITY OF CHULA VISTA ENGINEERING & CAPITAL PROJECTS STANDARD DRAWING	 WILLIAM S. VALLE CITY ENGINEER
ORIGINAL	DPH	W. VALLE	11/17		
				CURB INLET CURB HEIGHT AND PAVEMENT TRANSITION	DRN-09

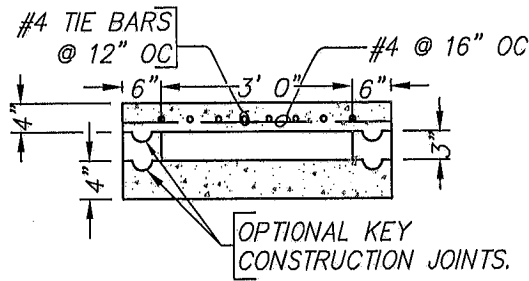

SECTION "A-A"
NO SCALE

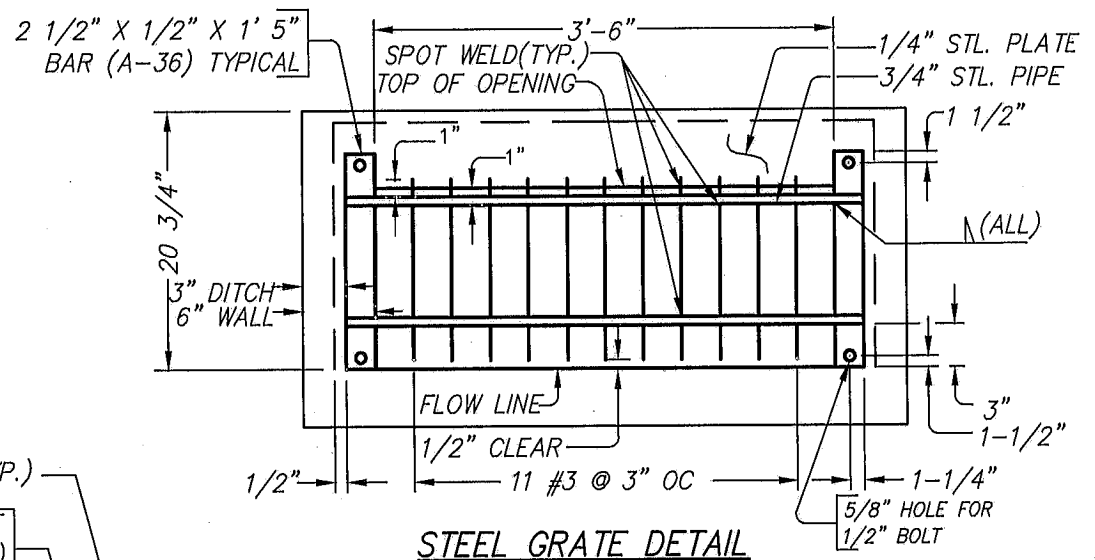

STEEL GRATE DETAIL
NO SCALE
GRATE TO BE HOT DIPPED GALVANIZED AFTER FABRICATION

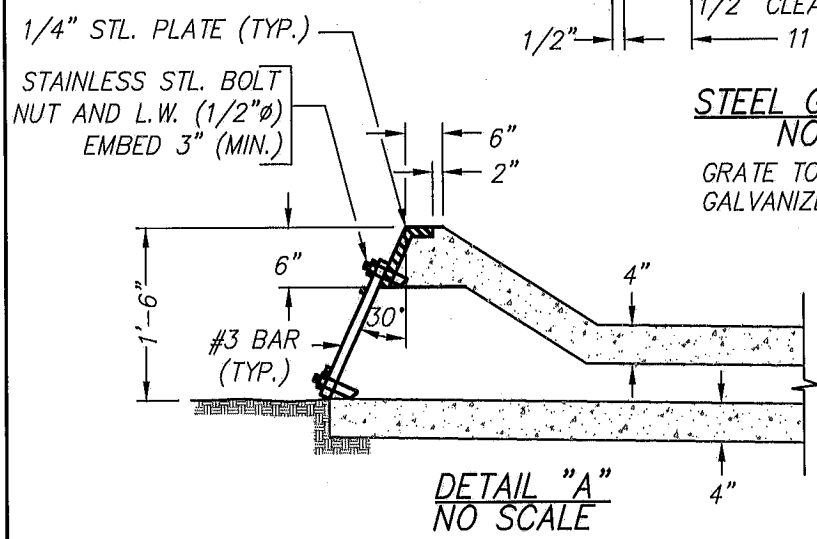

DETAIL "A"
NO SCALE

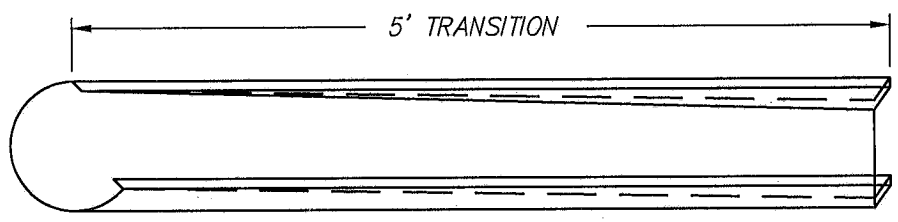

BROW DITCH TRANSITION DETAIL
NO SCALE

REVISION	BY	APPROVED	DATE
ORIGINAL			12/90
REVISION	CVM	C. SWANSON	11/02
REVISION	DPH	W. VALLE	11/17

CITY OF CHULA VISTA
ENGINEERING & CAPITAL PROJECTS
STANDARD DRAWING
SIDEWALK UNDERDRAIN BROW DITCH
TRANSITION DETAIL

William S. Valle
WILLIAM S. VALLE 11/21/2017
CITY ENGINEER
DRN-10

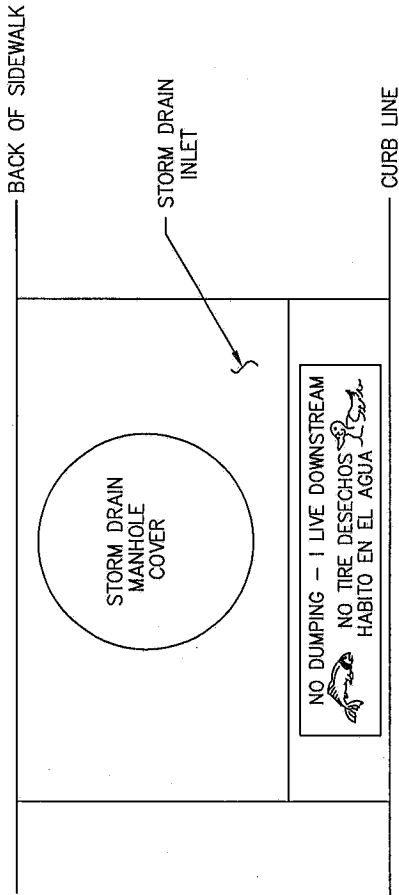

PLAN VIEW

STENCIL LOCATION
NO SCALE

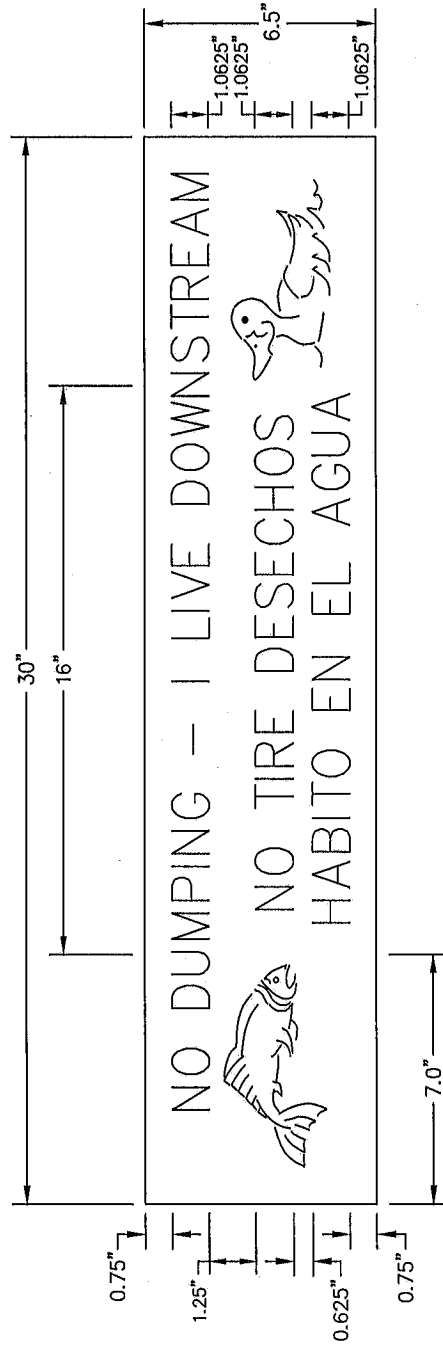

DETAIL: STENCIL

NO SCALE

NOTES:

1. DEPTH OF IMPRINT SHALL BE 0.25 INCH, MINIMUM.
2. STAMP SHALL BE RIGID AND FABRICATED FROM METAL, HARD RUBBER, OR APPROVED EQUAL.

REVISION	BY	APPROVED	DATE	CITY OF CHULA VISTA ENGINEERING & CAPITAL PROJECTS STANDARD DRAWING	 WILLIAM S. VALLE 11/21/2017 CITY ENGINEER
ORIGINAL	CVM	C. SWANSON	11/02		
REVISION	DPH	W. VALLE	11/17		
STORM DRAIN STENCIL				DRN-11	

NOTES:

- 1: CITY ENGINEER MAY APPROVE ALTERNATE DESIGNS AND PRODUCTS
- 2: PIPE PRODUCTS, FABRICS, ETC. SHALL BE IN ACCORDANCE WITH MANUFACTURER'S RECOMMENDATIONS AND/OR THE STANDARD SPECIFICATIONS.
- 3: PLACE HEADWALL APPROX. 10 FEET FROM STORM DRAIN TIE IN.
- 4: COORDINATE AREA DRAIN LOCATIONS WITH PROPOSED TREE LOCATIONS.
- 5: SOLID PIPE FITTINGS USE SAN SEWER ANGLE & WYE CONNECTIONS.

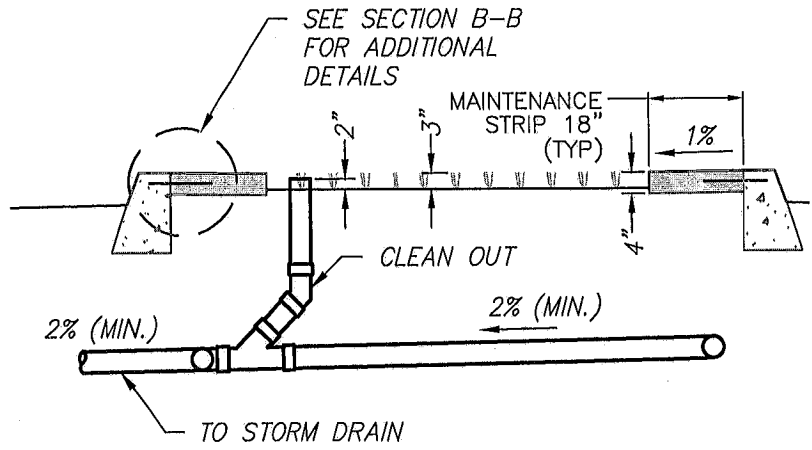

SECTION A-A

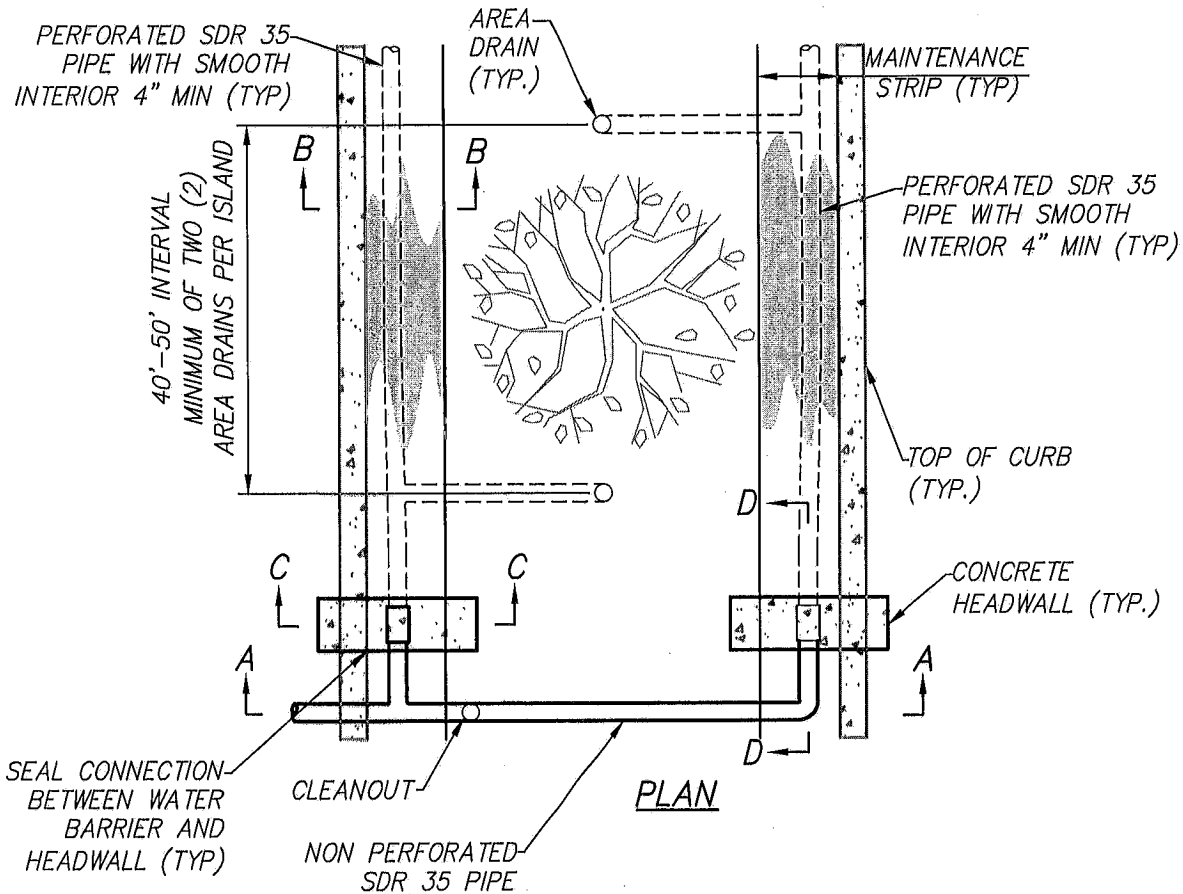

SHEET 1 OF 2

REVISION	BY	APPROVED	DATE	CITY OF CHULA VISTA ENGINEERING & CAPITAL PROJECTS STANDARD DRAWING	 WILLIAM S. VALLE CITY ENGINEER
ORIGINAL			07/75		
REVISION	CVM	C. SWANSON	11/02		
REVISION	DPH	W. VALLE	11/17		11/21/2017
				LANDSCAPE MEDIAN DRAIN	DRN-12

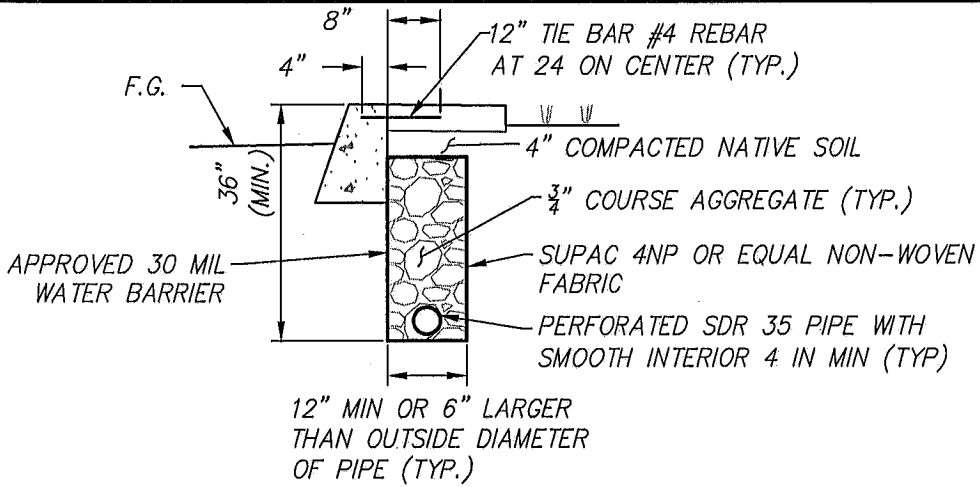

SECTION B-B
PERFORATED PIPE ALONG MEDIAN CURB

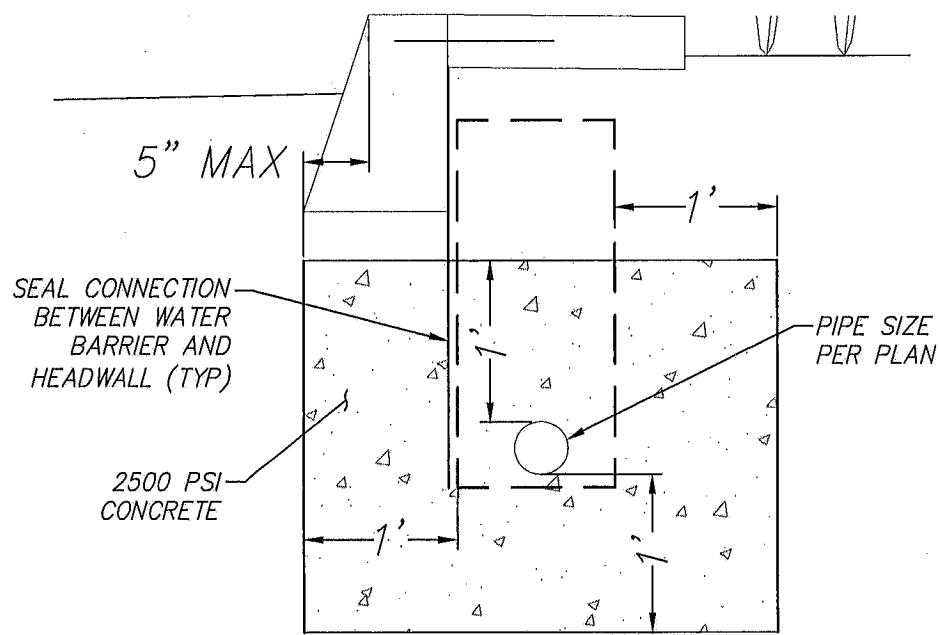

SECTION C-C:
PERFORATED PIPE CONNECTION AT HEADWALL

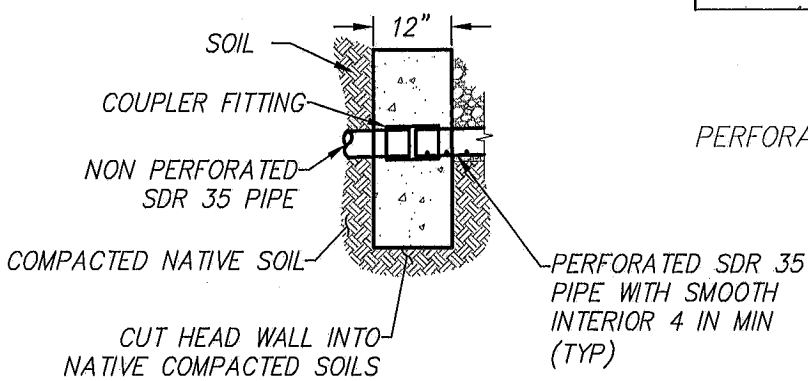

SECTION D-D
PERFORATED PIPE COUPLING AT HEADWALL

SHEET 2 OF 2

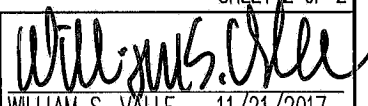
REVISION	BY	APPROVED	DATE	CITY OF CHULA VISTA ENGINEERING & CAPITAL PROJECTS STANDARD DRAWING	 WILLIAM S. VALLE CITY ENGINEER
ORIGINAL			07/75		
REVISION	CVM	C. SWANSON	11/02		
REVISION	DPH	W. VALLE	11/17	LANDSCAPE MEDIAN DRAIN SECTIONS	11/21/2017
					DRN-12

GRADING

(GRD)



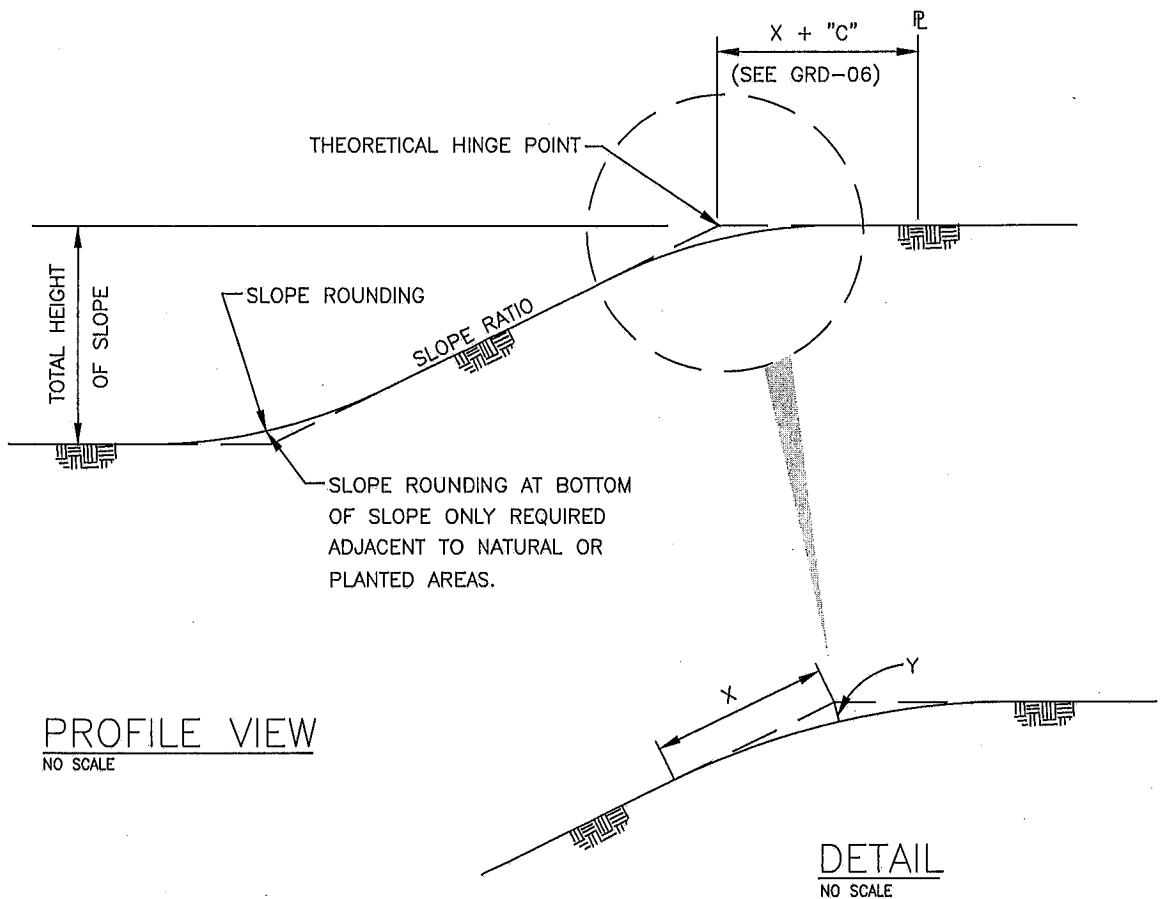

X = DISTANCE FROM THEORETICAL HINGE POINT TO POINT OF TANGENCY.
 Y = DEPTH OF CUT AT THEORETICAL HINGE POINT.

VERTICAL SLOPE ROUNING				
SLOPE RATIO	TOP OF SLOPE		BOTTOM OF SLOPE AND BENCHES	
	X	Y	X	Y
STEEPER THAN 2:1	16'	3'	8'	1.5'
2:1 TO 3:1	10'	2'	5'	1'
FLATTER THAN 3:1	6'	1'	3'	0.5'

NOTES:

1. SLOPE ROUNING IS REQUIRED FOR ALL SLOPES, EXCEPT WHERE WALLS ARE INSTALLED PER DEPARTMENT OF PLANNING AND BUILDING REQUIREMENTS.
2. FOR SLOPE GRADING AND SLOPE BENCHES, SEE GRD-06.
3. FOR BROW AND TERRACE DITCHES, SEE REG. STD. DWG. D-75.

REVISION	BY	APPROVED	DATE
ORIGINAL			07/75
REVISION	CM	C. SWANSON	11/02
REVISION	DPH	W. VALLE	11/17

CITY OF CHULA VISTA
 ENGINEERING & CAPITAL PROJECTS
 STANDARD DRAWING

VERTICAL SLOPE ROUNING

William S. Valle
 WILLIAM S. VALLE 11/21/2017
 CITY ENGINEER

GRD-01

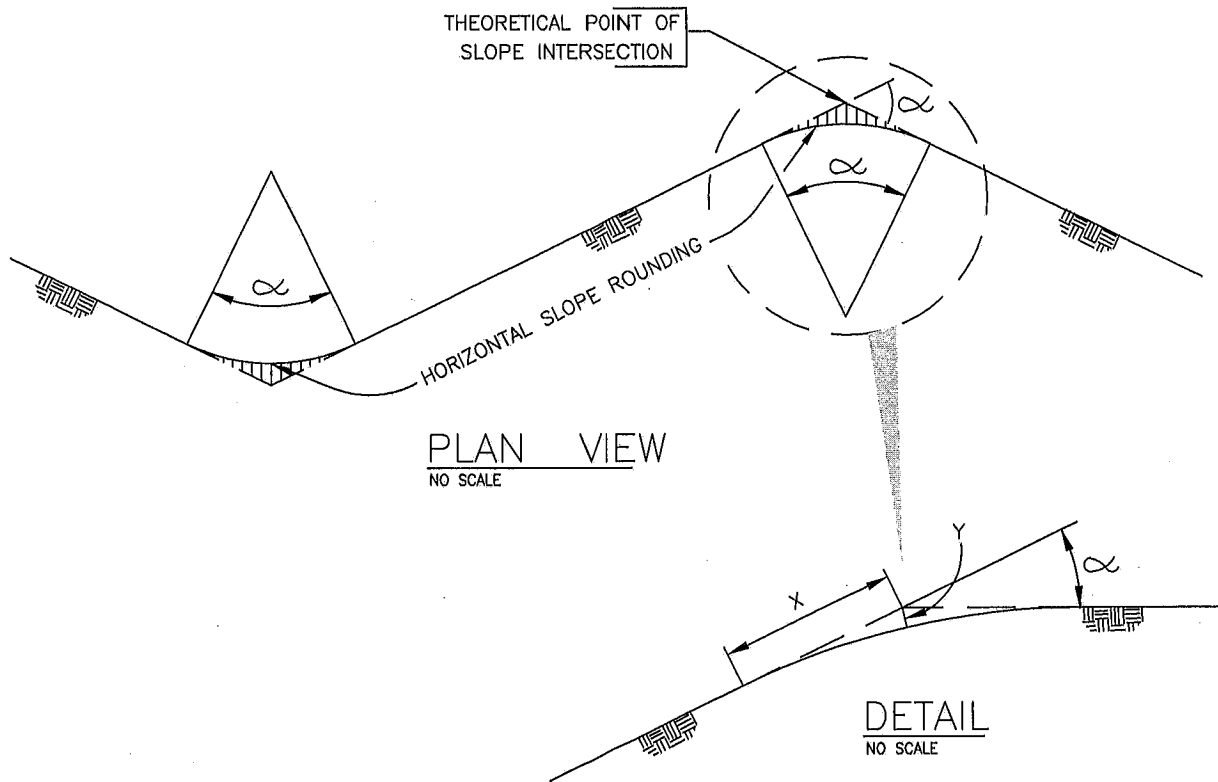

NOTES: SLOPE ROUNDING IS REQUIRED FOR ALL SLOPES.

X = DISTANCE FROM THEORETICAL POINT OF SLOPE INTERSECTION TO POINT OF TANGENCY.

Y = DEPTH OF CUT AT THEORETICAL POINT OF SLOPE INTERSECTION.

α = ANGLE OF SLOPE INTERSECTION.

HORIZONTAL SLOPE ROUNDING		
(α) ANGLE OF SLOPE INTERSECTION	X	Y
MORE THAN 60°	29'	8'
30° - 60°	21'	5'
LESS THAN 30°	14'	2'

REVISION	BY	APPROVED	DATE
ORIGINAL			07/75
REVISION	CM	C. SWANSON	11/02
REVISION	DPH	W. VALLE	11/17

CITY OF CHULA VISTA
ENGINEERING & CAPITAL PROJECTS
STANDARD DRAWING

William S. Valle
WILLIAM S. VALLE 11/21/2017
CITY ENGINEER

HORIZONTAL SLOPE ROUNDING

GRD-02

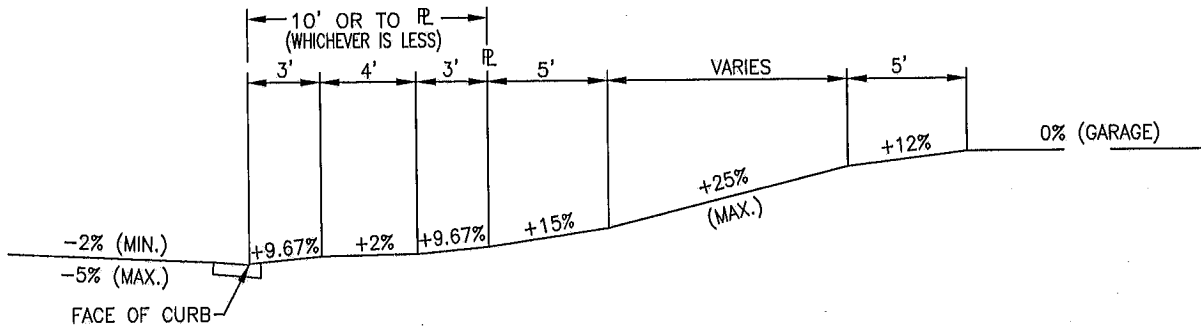

UPHILL DRIVEWAY
NO SCALE

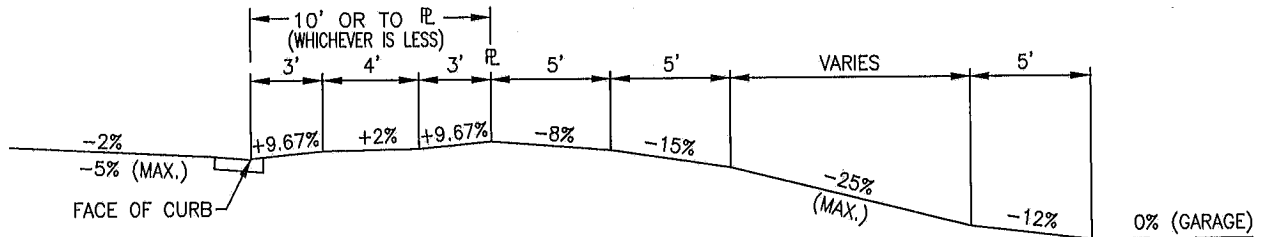

DOWNHILL DRIVEWAY
NO SCALE

NOTES:

1. PORTLAND CEMENT CONCRETE 564-C-3000 SHALL BE USED IF ANY PORTION OF DRIVEWAY GRADE EXCEEDS 12%.
2. VERTICAL CURVES (6' MIN. LENGTH) SHALL BE USED FOR CHANGE OF GRADE OF 6% OR GREATER.
3. SEE GSI-01 FOR CONSTRUCTION OF DRIVEWAY APPROACH.

REVISION	BY	APPROVED	DATE
ORIGINAL			10/74
REVISION	CVM	C. SWANSON	11/02
REVISION	DPH	W. VALLE	11/17

CITY OF CHULA VISTA
ENGINEERING & CAPITAL PROJECTS
STANDARD DRAWING

William S. Valle
WILLIAM S. VALLE 11/21/2017
CITY ENGINEER

DRIVEWAYS VERTICAL DESIGN

GRD-03

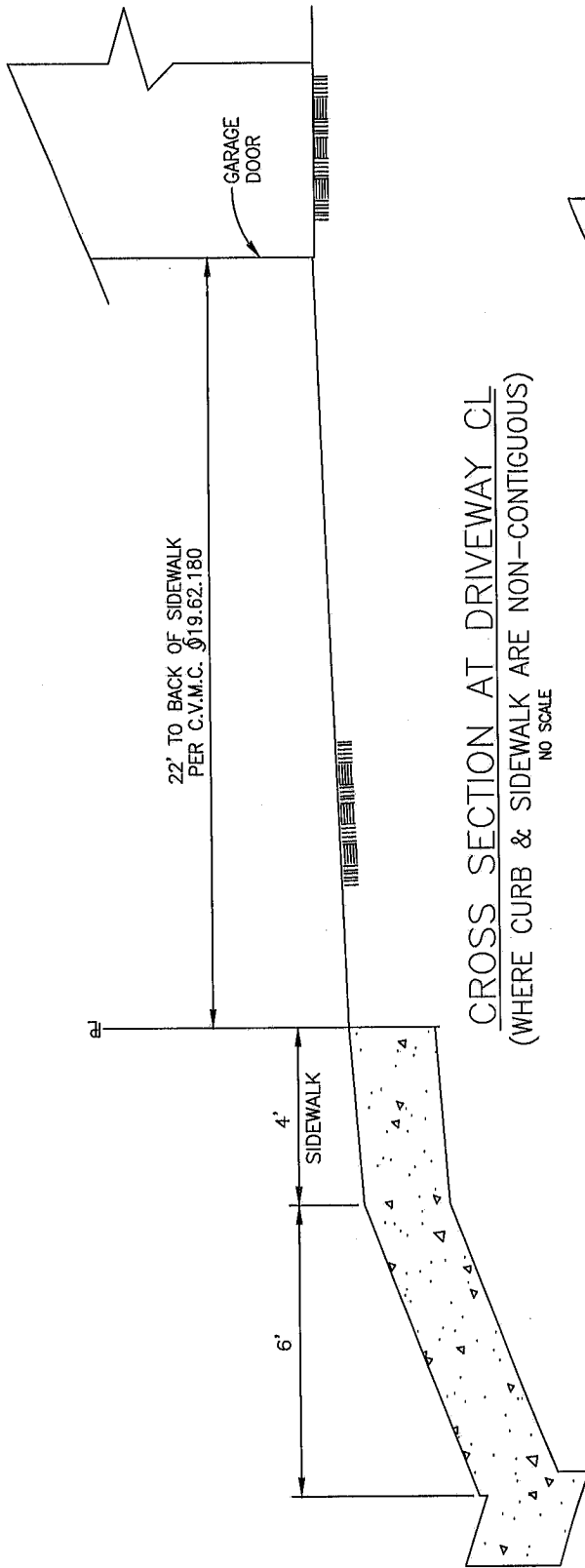

CROSS SECTION AT DRIVEWAY CL
(WHERE CURB & SIDEWALK ARE NON-CONTIGUOUS)
NO SCALE

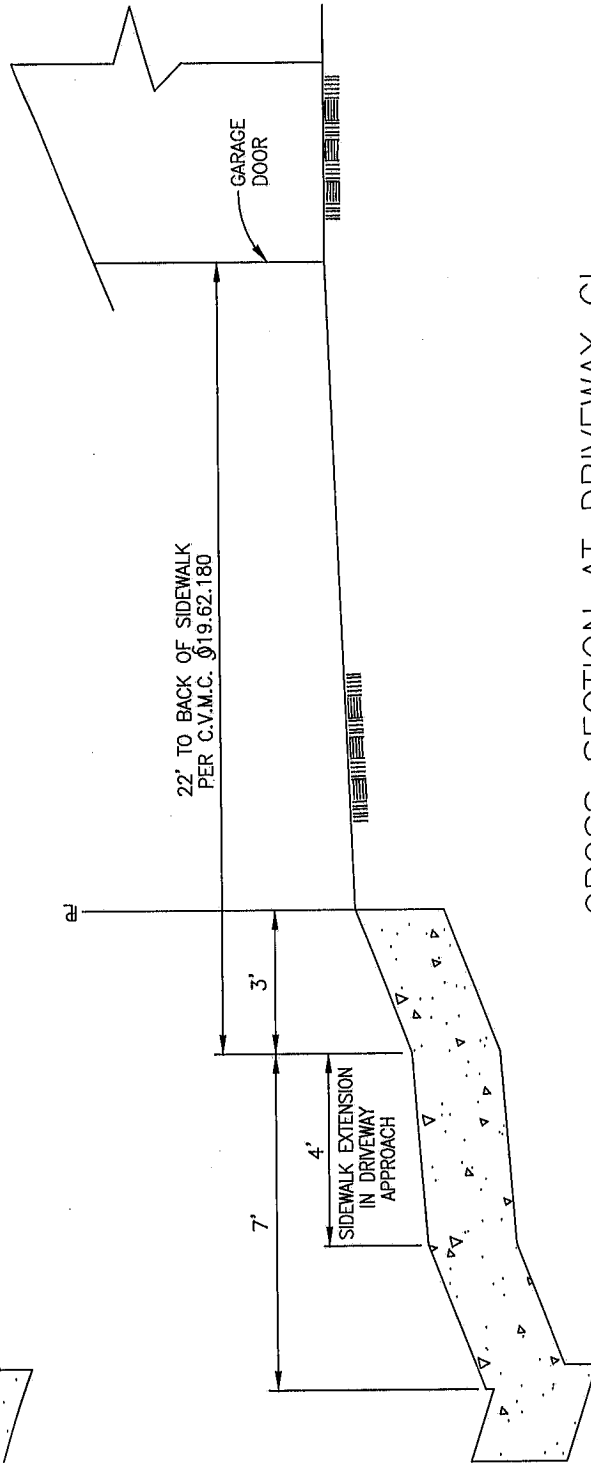

CROSS SECTION AT DRIVEWAY CL
(WHERE CURB & SIDEWALK ARE CONTIGUOUS)
NO SCALE

NOTE
SEE GSI-01 FOR ADDITIONAL NOTES, DETAILS AND DIMENSIONS FOR DRIVEWAYS.

REVISION	BY	APPROVED	DATE
ORIGINAL			01/98
REVISION	CVM	C. SWANSON	11/02
REVISION	DPH	W. VALLE	11/17

CITY OF CHULA VISTA
ENGINEERING & CAPITAL PROJECTS
STANDARD DRAWING
DRIVEWAYS MINIMUM GARAGE
SETBACK

William S. Valle
WILLIAM S. VALLE 11/21/2017
CITY ENGINEER
GRD-04

MASONRY RETAINING WALLS

The City of Chula Vista requires a permit for the construction of retaining walls, except those less than three feet in height and not supporting surcharge. This publication outlines the city's requirements for retaining walls with level backfill, with sloping backfill and with vehicular surcharge.

If construction does not involve grading, contact the Building Division of the Planning & Building Department for information on how to obtain a permit for a retaining wall (619-691-5272). If construction does involve grading, contact the Engineering Division of the Public Works Department (619-691-5024).

I. INSPECTIONS

You must call the City for inspections after several specific phases of construction. To schedule an inspection for a retaining wall permit having a permit number starting with a "B", call the Building Division at (619) 691-5009. For permit numbers starting with "PG", call the Engineering Division at (619) 585-5737.

Please call for these inspections at the following times, and do not proceed to the next phase of construction until the City inspector has given you written approval to proceed:

A. Call for a footing inspection after you have made the excavation for the footing, tied the steel securely in its final position, and made the site ready for concrete placement. Do not place concrete until the City inspector has given you written approval to proceed.

B. Call for a masonry pre-grout inspection after you have laid the block and have set the reinforcing steel in place, but before you place the grout. Do not lay blocks higher than 6 feet without a pre-grout inspection.

1. If cleanout holes are required, lay the block to the full height of the grout pour before you call for the pre-grout inspection. Place grout in a continuous pour in grout lifts not more than 4 feet in height.
2. If cleanout holes are not required, call for a masonry pre-grout inspection prior to each grout pour. Do not lay block higher than the grout pour. Note that cleanouts are required for all grout pours over 5 feet in height.

C. Call for a backfill/drainage inspection after grouting is completed and rock or rubble wall drains are in place, but before earth backfill is placed.

D. Call for a final inspection after you have completed the construction and, if the City has required one, after a licensed professional has prepared a compaction report. (See Section VII).

SHEET 1 OF 16

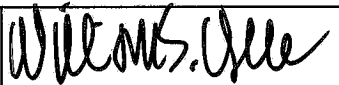
REVISION	BY	APPROVED	DATE	CITY OF CHULA VISTA ENGINEERING & CAPITAL PROJECTS STANDARD DRAWING	
ORIGINAL	CVM	C. SWANSON	12/01		WILLIAM S. VALLE 11/21/2017 CITY ENGINEER
REVISION	DPH	W. VALLE	11/17	RETAINING WALL REQUIREMENTS PUBLICATION OUTLINES	GRD-05

II. DESIGN TABLES

The design tables, found towards the end of this publication, address a variety of different loading conditions and footing configurations. If you have a loading condition that is not shown in this publication, you must have a licensed professional engineer or architect design the wall specifically for conditions existing on the site. Examples of loading conditions not covered in this publication include walls supporting building foundations and walls subjected to truck traffic surcharge greater than 250 psf, unless those loads are applied away from the wall a distance at least equal to the height of the wall.

Retaining wall height is measured from the top of the footing to the top of the wall. You must not build higher than the design height of the wall.

III. BLOCK

All block must be Type "N", grouted solid. (Design $f'_m = 1,500$ psi)

IV. CONCRETE MIX REQUIREMENTS

Note: Use of plastic cement is not permitted in retaining walls located in this Seismic Zone.

A. The concrete mix footings must have a compressive strength of at least $f'_c = 2,500$ psi in 28 days. You may use a mix containing the following proportions by volume.

- 1 part Portland cement
- 2 1/2 parts sand
- 3 1/2 parts 3/4-inch maximum-size gravel
- 7 gallons of water maximum per sack of cement

Note: Hand mixed concrete and grout are not permitted on projects subject to the "Standard Specifications for Public Works Construction" ("Green Book".)

B. The mortar mix must have a compressive strength of at least 1,800 psi. You may use a mix containing the following proportions by volume:

- 1 part Portland cement
- 3 1/2 parts sand
- 1/4 part hydrated lime or lime putty

C. Grout must have a compressive strength of at least 2,000 psi in 28 days. You may use a mix containing the following proportions by volume:

- 1 part Portland cement
- 3 parts sand
- 2 parts pea gravel (3/8-inch aggregate)

REVISION	BY	APPROVED	DATE	CITY OF CHULA VISTA ENGINEERING & CAPITAL PROJECTS STANDARD DRAWING	
ORIGINAL	CVM	C. SWANSON	12/01		
REVISION	DPH	W. VALLE	11/17	RETAINING WALL REQUIREMENTS PUBLICATION OUTLINES	WILLIAM S. VALLE 11/21/2017 CITY ENGINEER
					GRD-05

Note: Hand mixed concrete and grout are not permitted on projects subject to the "Standard Specifications for Public Works Construction" ("Green Book".)

Add water until you achieve pouring consistency without segregating the grout components. Rod or vibrate immediately. Re-rod or re-vibrate the grout about 10 minutes after pouring to ensure proper consolidation. When the grouting of a second lift is to be continued at later time, stop the grout placement 2 inches from the top of the masonry units.

Note: All cells must be filled solid with grout.

V. MORTAR KEY

To obtain proper bonding between the footing and the first course of block, form a mortar key by embedding a flat 2 x 4 flush with, and at the top of, the freshly placed footing concrete (See Drawing CVCS 33). Remove the 2 x 4 after the concrete has started to harden (about 1 hour). You may omit a mortar key if you set the first course of block into the freshly placed concrete footing.

VI. WALL DRAINS

Provide wall drains (4-inch-diameter) at 6-foot intervals along the length of the wall and located just above the level of the soil or paving on the front face of the wall (See Drawing CVCS 33). Alternatively, form the drains by placing a block on its side at 6-foot intervals, by leaving out the mortar in the vertical spaces between all the blocks in the first course above the soil, by paving (head joint) on the front face of the wall, or by some other equivalent method acceptable to the City. Backfill behind wall drains or open head joints must be 12 inches wide filled with gravel and must extend from the top of the footing to above the top of the drain or open joint.

VII. SOIL

Wall design, footing sizes and reinforcing steel are all based on an active earth pressure with an equivalent fluid pressure of 36 psf and a weight of 120 pounds per cubic foot (pcf). Extend all footings at least 12 inches into undisturbed natural soil or into fill that has been compacted to at least 90 percent density. Dampen soil prior to placing concrete in footings. Where the ground slopes away from the base of the wall, you must have a horizontal distance of at least 7 feet from the toe of the footing to "daylight" (See Drawing CVCS 33). The City may require a soils report, prepared by a licensed civil engineer specialized in soil mechanics or a licensed geotechnical engineer, depending on soil conditions at the site.

Footing sizes in the attached tables are based on a 1,000 psf maximum soil bearing value. If you wish to take advantage of a higher bearing value, you must have a licensed architect (a licensed architect may not design Public Works walls that are

REVISION	BY	APPROVED	DATE	CITY OF CHULA VISTA ENGINEERING & CAPITAL PROJECTS STANDARD DRAWING	
ORIGINAL	CVM	C. SWANSON	12/01		
REVISION	DPH	W. VALLE	11/17	RETAINING WALL REQUIREMENTS PUBLICATION OUTLINES	WILLIAM S. VALLE 11/21/2017 CITY ENGINEER
					GRD-05

in the right-of-way) or civil/structural engineer design the wall(s) specifically for the existing site conditions. Again, the City may require a soils report, prepared by a licensed civil engineer specialized in soil mechanics or a licensed geotechnical engineer, depending on soil conditions at the site.

VIII. REINFORCING STEEL

Use reinforcing steel bars which conform to ASTM specification A615-85, Grade 40 or 60. When you can't use one continuous bar, you must lap or splice bars a distance of at least 40-bar diameters (i.e. 15" for #3 bars, 20" for #4 bars, 25" for #5 bars, 30" for #6 bars). The required minimum lap splice for bars of different size to be based on the diameter of the larger size bar. Bends in the reinforcing steel must conform to the Manual of Standard Practice, American Concrete Institute. Backing for hooks must be at least a distance equal to four bar diameters. All required bar embedment dimensions are clear distances to outside of bar. Spacing for parallel bars is center to center of bars.

Place two or more bars longitudinally in the footing (See Tables for number of bars needed). For 6-inch or 8-inch blocks, place one #3 bar longitudinally in the center of the wall in a bond beam block every 16 inches of wall height as the blocks are laid up. For 12-inch blocks, place one #4 bar longitudinally in the center of the wall in a bond beam block every 16 inches of wall height as the blocks are laid up.

IX. JOINTS

Vertical control joints are needed at intervals of not more than 32 feet. Joints must resist shear and other lateral forces and still permit longitudinal movement. Vertical expansion joints are needed at intervals of not more than 96 feet (See Drawing CVCS 34).

X. STEP FOOTINGS

Base the footing dimensions and the amount of reinforcing steel on the maximum height of the wall on either side of a step in the footing elevation. The construction of the step must follow the details on Drawing CVCS 34.

XI. BACKFILL

Do not place backfill material against a masonry retaining wall until the grout has either reached design strength or has cured for a minimum of 28 days. Compaction of backfill material by either jetting or ponding with water is not permitted. Each layer of backfill must be moistened and thoroughly tamped, rolled or otherwise compacted until the relative compaction is not less than 90%. If the wall is within the City right-of-way, subject to vehicular surcharge or

REVISION	BY	APPROVED	DATE	CITY OF CHULA VISTA ENGINEERING & CAPITAL PROJECTS STANDARD DRAWING	
ORIGINAL	CVM	C. SWANSON	12/01		
REVISION	DPH	W. VALLE	11/17		
				RETAINING WALL REQUIREMENTS PUBLICATION OUTLINES	WILLIAM S. VALLE 11/21/2017 CITY ENGINEER
					GRD-05

subject to the "Standard Specifications for Public Works Construction" (Green Book"), the City will require a compaction test and certificate, from a soil engineer, showing that the entire fill has been compacted to at least 90%.

XII. FENCING

If a pedestrian walkway is adjacent to the top of a retaining wall that is more than 30-inches in height, you must install safety fencing at the top of the wall. If a wall is greater than 30-inches in height and is adjacent to a street, driveway or parking area, you must install a vehicular guardrail at the top of the wall.

XIII. USE OF TABLES

First, determine the height of wall you need to construct. Then determine the slope of retained earth or if the wall supports vehicular surcharge. Based on what distance you choose from the footing toe to the face of wall, use the table with the necessary wall height and slope of retained earth or surcharge. From the appropriate table, copy the wall design information, including block width, reinforcing steel size and spacing, and footing and key dimensions, on to a copy of the City's typical wall section form (Drawings CVCS 31 or CVCS 32). Use a separate form for each different design of wall. (One wall design may be used for all walls of a certain height and lower. However, there may be savings in material costs if a different, more economical, design is used for walls of lower height). Indicate on each form the locations on the property that the particular wall design will be used. See EXAMPLE at end of the attached forms.

XIV. PLAN SUBMITTAL

Prepare a land development plan (for Engineering Division permits) or plot plan (for Building Division permits) showing the location, type and height of each wall. Show all adjacent structures, driveways, parking areas and pedestrian walkways. Attach a completed form for each proposed wall design, as well as a copy of this procedure with the (following) disclaimer signed and dated.

XV. DISCLAIMER

These design standards indicate a minimum acceptable design for retaining walls meeting very specific field conditions and construction procedures. City approval of retaining walls and any related improvements shall not constitute a representation of the adequacy of the design or engineering of such retaining walls or improvements, nor shall it constitute an implied representation as to its suitability or fitness for any particular purpose. The City assumes no liability or any responsibility for damage or failure. The owner should consult with an appropriate Registered Civil Engineer or licensed architect.

REVISION	BY	APPROVED	DATE	CITY OF CHULA VISTA ENGINEERING & CAPITAL PROJECTS STANDARD DRAWING	
ORIGINAL	CVM	C. SWANSON	12/01		
REVISION	DPH	W. VALLE	11/17	RETAINING WALL REQUIREMENTS PUBLICATION OUTLINES	WILLIAM S. VALLE 11/21/2017 CITY ENGINEER
					GRD-05

HOW TO USE THE DESIGN TABLES

- Based on the site conditions and retaining wall location, determine if the wall will have a variable heel size (no limitation on the size of the heel), a 6-in or 2-in heel size, then
- Determine if the wall is retaining a level or sloping backfill, or level backfill with vehicular surcharge, then
- Based on the conditions noted above, select the appropriate design table (for ex. Variable heel (Minimum toe), 1.5 to 1 slope), then
- Move across the table and find the applicable retaining wall height (for ex. 6'-8"). Retaining wall height is measured from the top of the footing to to the top of the wall. The design data found under that column (for ex. column titled CVV15-68) is what applies to the wall. Then,
- From the design data under the applicable column, determine if the wall is TYPE I or II, in case of the example TYPE II, then
- Transfer the design data to the appropriate drawing, CVCS 31 for TYPE I wall and CVCS 32 for TYPE II wall, as shown on the attached example, then
- Indicate on the plot plan the location and extent of where each wall type (for ex. CVV15-68) is to be built.
- Repeat the above steps for each wall with different height and/or conditions (for ex. heel size, backfill slope or vehicular surcharge).

SHEET 6 OF 16

REVISION	BY	APPROVED	DATE	CITY OF CHULA VISTA ENGINEERING & CAPITAL PROJECTS STANDARD DRAWING	<i>William S. Valle</i>
ORIGINAL	CVM	C. SWANSON	12/01	RETAINING WALL REQUIREMENTS PUBLICATION OUTLINES	WILLIAM S. VALLE 11/21/2017 CITY ENGINEER
REVISION	DPH	W. VALLE	11/17		GRD-05

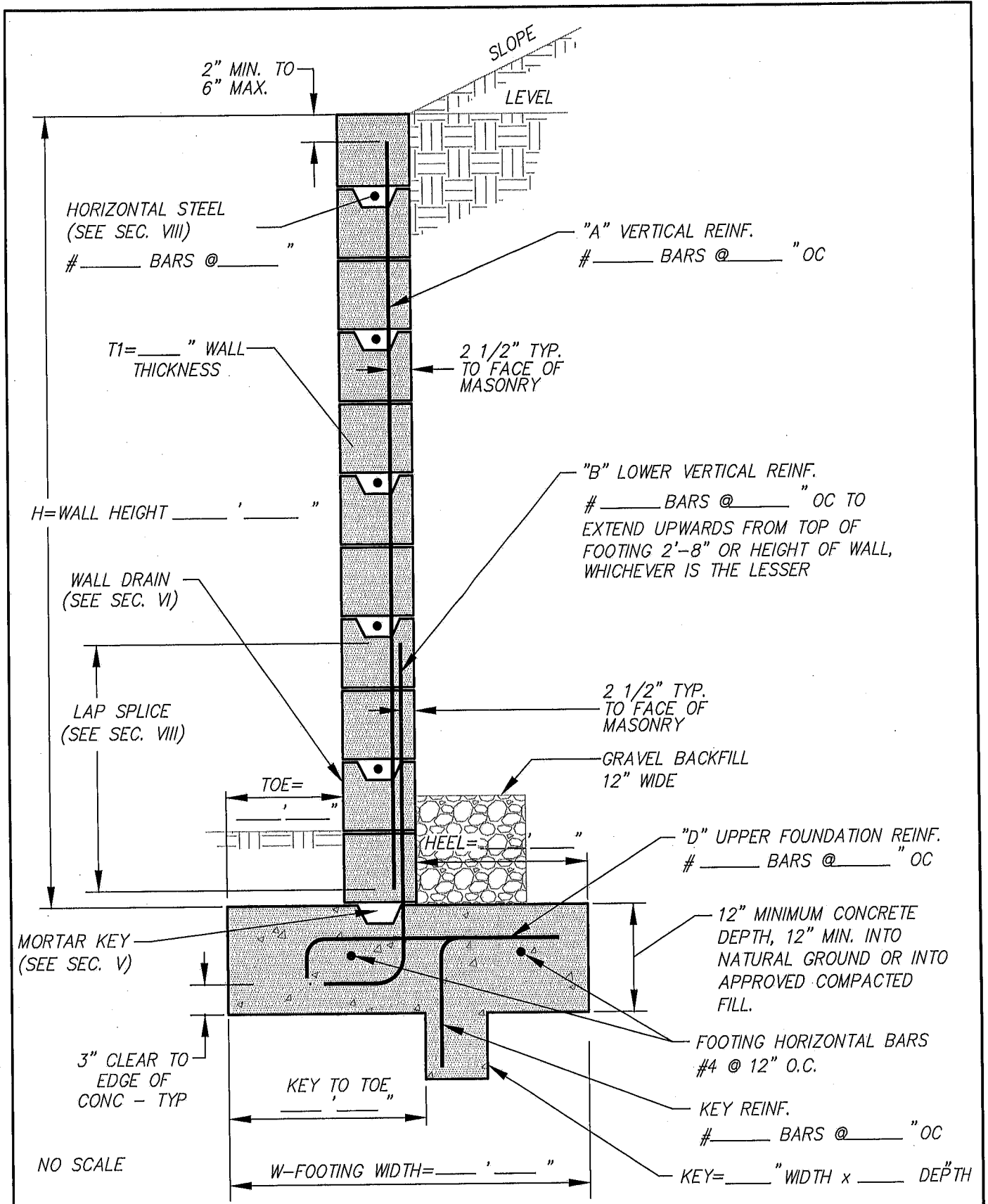

SHEET 7 OF 16

REVISION	BY	APPROVED	DATE
ORIGINAL	CVM	C. SWANSON	12/01
REVISION	DPH	W. VALLE	11/17

CITY OF CHULA VISTA
ENGINEERING & CAPITAL PROJECTS
STANDARD DRAWING

RETAINING WALL TYPE I

William S. Valle
WILLIAM S. VALLE 11/21/2017
CITY ENGINEER

GRD-05

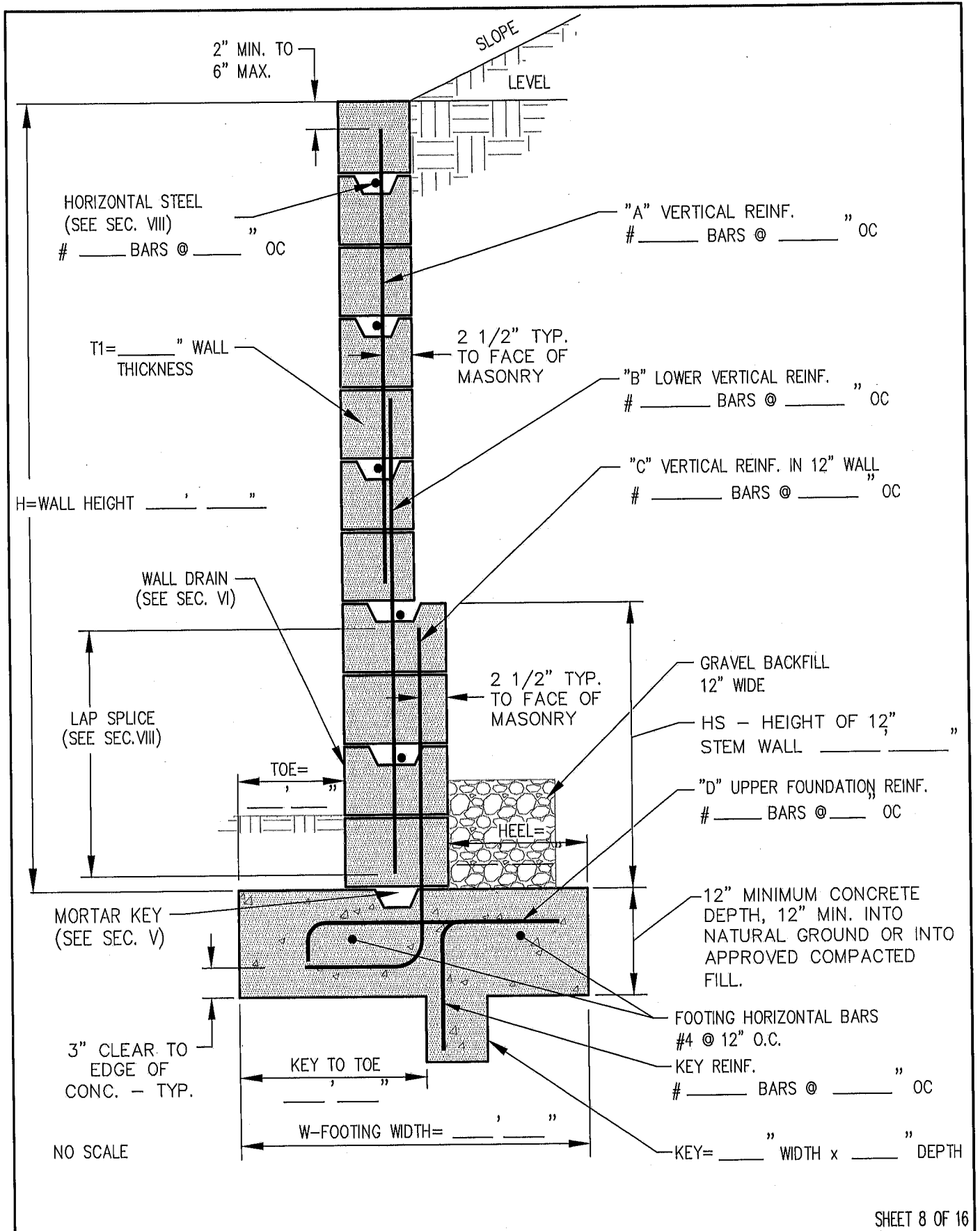

SHEET 8 OF 16

REVISION	BY	APPROVED	DATE	CITY OF CHULA VISTA ENGINEERING & CAPITAL PROJECTS STANDARD DRAWING	<i>William S. Valle</i> WILLIAM S. VALLE CITY ENGINEER
ORIGINAL	CVM	C. SWANSON	12/01		
REVISION	DPH	W. VALLE	11/17		11/21/2017
				RETAINING WALL TYPE II	GRD-05

RETAINING WALL

CAP, KEY & DRAINAGE DETAILS

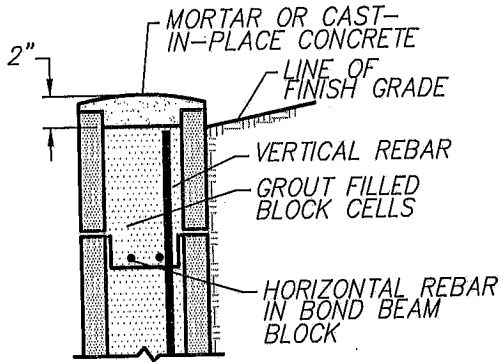

CAP DETAIL

SEE NOTE 1

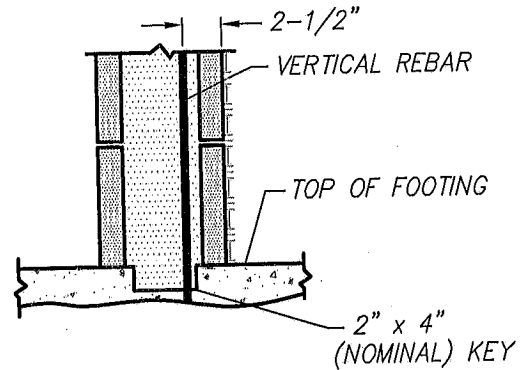

KEY DETAIL

SEE NOTE 1

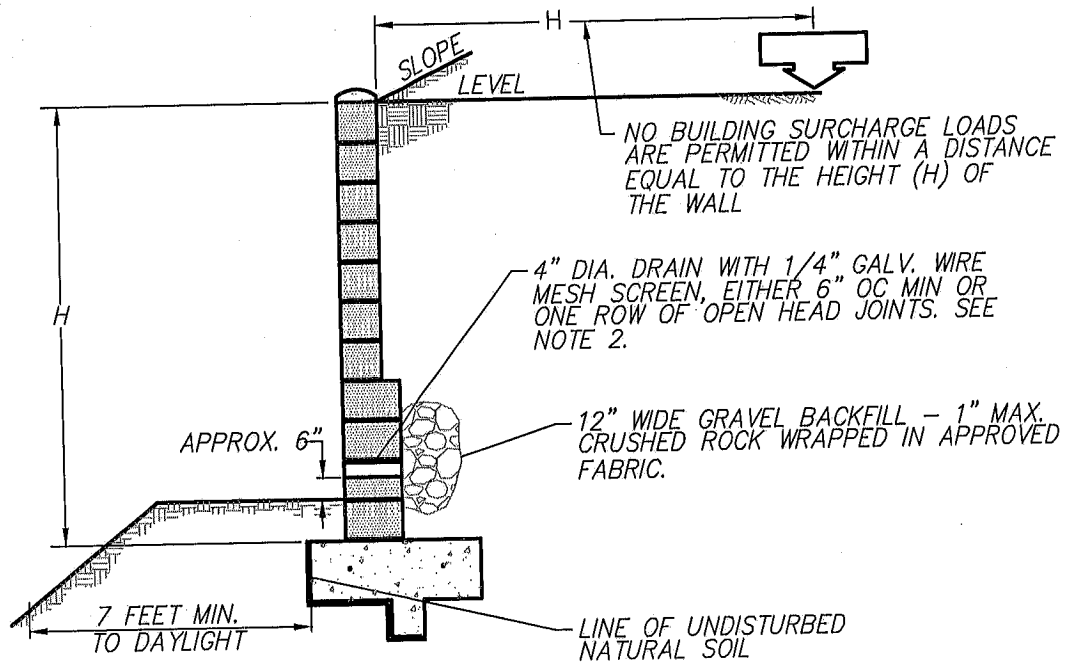

TYPICAL SECTION

NOTES:

1. ALL MASONRY WALLS MUST BE BUILT WITH CAP, KEY AND DRAINAGE DETAILS AS SHOWN ABOVE.
2. A 4-INCH DIAMETER DRAIN MAY BE FORMED BY PLACING A BLOCK ON ITS SIDE.

REVISION	BY	APPROVED	DATE	CITY OF CHULA VISTA ENGINEERING & CAPITAL PROJECTS STANDARD DRAWING	WILLIAM S. VALLE CITY ENGINEER
ORIGINAL	CVM	C. SWANSON	12/01		
REVISION	DPH	W. VALLE	11/17		
				RETAINING WALL, CAP, KEY, & DRAINAGE DETAILS	11/21/2017 GRD-05

RETAINING WALL

STEP FOOTING & JOINT DETAILS

STEP FOOTING
PLAN VIEW

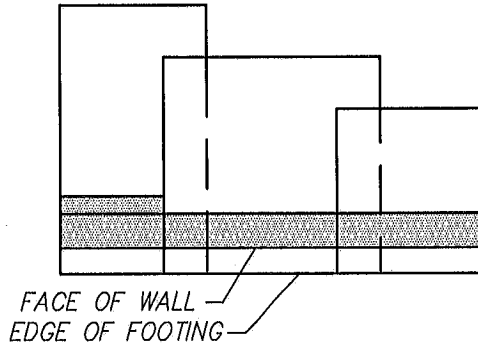

STEP FOOTING
ELEVATION

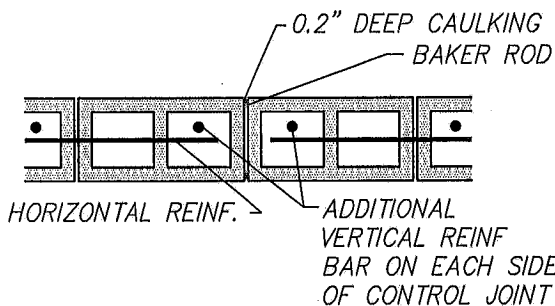
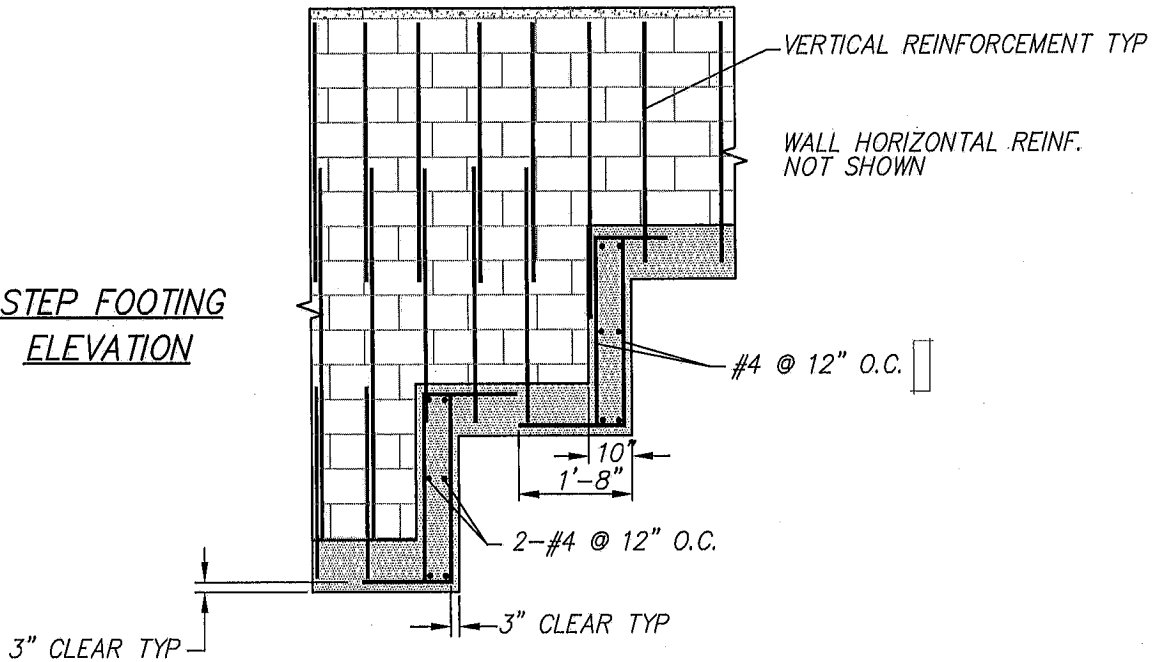

CONTROL JOINTS MUST EXTEND VERTICALLY EVERY 32 FT OC ALONG THE WALL. SOLID GROUT MAY CONTINUE THROUGH THE JOINT. RACK THE MORTAR BACK AT LEAST 1".

CONTROL JOINT

NO SCALE

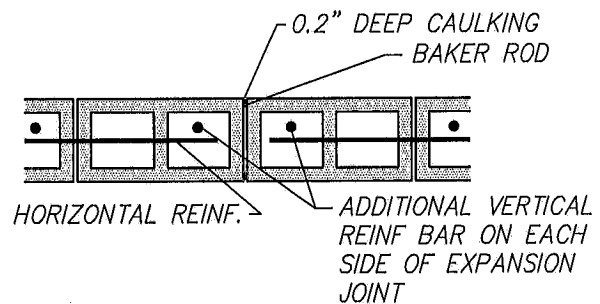

EXPANSION JOINTS MUST EXTEND VERTICALLY EVERY 96 FT OC ALONG THE WALL. JOINT MUST NOT CONTAIN ANY INCOMPRESSIBLE MATERIAL (EX. GROUT OR MORTAR).

EXPANSION JOINT

NO SCALE

SHEET 10 OF 16

REVISION	BY	APPROVED	DATE
ORIGINAL	CVM	C. SWANSON	12/01
REVISION	DPH	W. VALLE	11/17

CITY OF CHULA VISTA
ENGINEERING & CAPITAL PROJECTS
STANDARD DRAWING

RETAINING WALL STEP FOOTING &
JOINT DETAILS

William S. Valle
WILLIAM S. VALLE 11/21/2017
CITY ENGINEER

GRD-05

Variable heel (Minimum Toe), Level Backfill

CV Wall	CVVL-14	CVWL-20	CVVL-28	CVWL-34	CVVL-40	CVWL-48	CVWL-54	CVWL-60	CVWL-68	CVWL-74	CVWL-80
TYPE	I	I	I	I	I	I	I	I	I	I	I
Height -h	1'-4"	2'-0"	2'-8"	3'-4"	4'-0"	4'-8"	5'-4"	6'-0"	6'-8"	7'-4"	8'-0"
Slope	Level	Level	Level	Level	Level	Level	Level	Level	Level	Level	Level
Block-t1	6"	6"	6"	6"	8"	8"	8"	8"	8"	8"	8"
Stem Block											
Heel	0'-4"	0'-6"	0'-7"	0'-9"	0'-10"	1'-1"	1'-3"	1'-2"	1'-7"	1'-10"	2'-1"
Toe	0'-3"	0'-5"	0'-6"	0'-8"	0'-9"	1'-0"	1'-2"	1'-5"	1'-6"	1'-9"	2'-0"
Vert Bar-A				#3@24"	#4@24"	#4@24"	#4@24"	#4@24"	#4@24"	#4@24"	#4@24"
40 dia Lap				16"	20"	20"	20"	20"	20"	20"	20"
Horiz Bars	#3@16"	#3@16"	#3@16"	#3@16"	#3@16"	#3@16"	#3@16"	#4@16"	#4@16"	#4@16"	#4@16"
Lower Bar-B	#3@24"	#3@24"	#3@24"	#3@24"	#4@24"	#4@24"	#4@24"	#5@8"	#4@24"	#4@24"	#4@16"
Min. Height of 12" Stem Wall											
Stem Bar-C									#5@24"	#5@16"	#5@8"
Stem Horiz Bars									#4@16"	#4@16"	#4@16"
Top Bar-D									#4@16"	#4@16"	#4@12"
Footing Width-W	1'-1"	1'-5"	1'-7"	1'-11"	2'-3"	2'-9"	3'-1"	3'-7"	4'-1"	4'-7"	5'-1"
Footing Horiz Bars	2#4	2#4	3#4	3#4	3#4	4#4	4#4	5#4	5#4	6#4	6#4
Key to Toe	None	None	None	6" by 4"	6" by 6"	8" by 8"	12" by 10"	12" by 12"	12" by 13"	12" by 15"	12" by 18"
Key (w by d)											
Key Reinf											#4@16"

Variable heel (Minimum Toe), 2 to 1 Slope

CV Wall	CVV20-14	CVV20-20	CVV20-28	CVV20-34	CVV20-40	CVV20-48	CVV20-54	CVV20-60	CVV20-68	CVV20-74	CVV20-80
TYPE	I	I	I	I	I	I	I	I	I	I	I
Height -h	1'-4"	2'-0"	2'-8"	3'-4"	4'-0"	4'-8"	5'-4"	6'-0"	6'-8"	7'-4"	8'-0"
Slope	2.0:1	2.0:1	2.0:1	2.0:1	2.0:1	2.0:1	2.0:1	2.0:1	2.0:1	2.0:1	2.0:1
Block-t1	6"	6"	6"	8"	8"	8"	8"	8"	8"	8"	8"
Stem Block											
Heel	0'-8"	0'-6"	0'-8"	1'-2"	1'-4"	1'-1"	1'-10"	2'-9"	2'-6"	2'-6"	2'-6"
Toe	0'-2"	0'-6"	0'-8"	0'-8"	1'-0"	1'-6"	1'-6"	1'-6"	2'-0"	2'-6"	3'-0"
Vert Bar-A				#4@24"	#4@24"	#4@24"	#5@16"	#4@24"	#4@24"	#4@24"	#4@24"
40 dia Lap				20"	20"	20"	25"	20"	20"	20"	20"
Horiz Bars	#3@16"	#3@16"	#3@16"	#3@16"	#3@16"	#3@16"	#3@16"	#3@16"	#3@16"	#3@16"	#3@16"
Lower Bar-B	#3@24"	#3@24"	#3@24"	#4@24"	#4@24"	#4@16"	#5@8"	#4@24"	#4@24"	#4@24"	#4@16"
Min. Height of 12" Stem Wall											
Stem Bar-C									#6@16"	#6@8"	#8@8"
Stem Horiz Bars									#4@16"	#4@16"	#4@16"
Top Bar-D									#4@12"	#5@16"	#5@12"
Footing Width-W	1'-4"	1'-6"	1'-10"	2'-6"	3'-0"	3'-3"	4'-0"	5'-3"	5'-6"	6'-0"	6'-6"
Footing Horiz Bars	3#4	3#4	3#4	4#4	4#4	4#4	5#4	6#4	7#4	7#4	8#4
Key to Toe	0'-7"	0'-7"	1'-0"	1'-1"	1'-1"	1'-6"	2'-4"	3'-0"	2'-9"	2'-4"	2'-0"
Key (w by d)	6" by 4"	6" by 4"	8" by 8"	12" by 11"	12" by 14"	12" by 18"	12" by 22"	12" by 25"	12" by 29"	12" by 33"	12" by 37"
Key Reinf						#4@16"	#4@16"	#4@16"	#4@16"	#4@16"	#4@16"

REVISION	BY	APPROVED	DATE
ORIGINAL	CVM	C. SWANSON	12/01
REVISION	DPH	W. VALLE	11/17

CITY OF CHULA VISTA
 ENGINEERING & CAPITAL PROJECTS
 STANDARD DRAWING

TABLE FOR VARIABLE HEEL, LEVEL
 BACKFILL, & 2 TO 1 SLOPE

William S. Valle
 WILLIAM S. VALLE 11/21/2017
 CITY ENGINEER

GRD-05

Variable heel (Minimum Toe), 1.5 TO 1 Slope

CV Wall	CWV15-14	CWV15-20	CWV15-28	CWV15-34	CWV15-40	CWV15-48	CWV15-54	CWV15-60	CWV15-68	CWV15-74
TYPE	I	I	I	I	I	I	I	I	I	I
Height -h	1'-4"	2'-0"	2'-8"	3'-4"	4'-0"	4'-8"	5'-4"	6'-0"	6'-8"	7'-4"
Slope	1.5:1	1.5:1	1.5:1	1.5:1	1.5:1	1.5:1	1.5:1	1.5:1	1.5:1	1.5:1
Block-t1	6"	6"	6"	8"	8"	8"	8"	8"	8"	8"
Stem Block										
Heel	0'-8"	0'-9"	0'-11"	1'-0"	1'-3"	2'-1"	1'-9"	2'-0"	2'-4"	1'-7"
Toe	0'-4"	0'-8"	0'-10"	0'-11"	1'-2"	1'-2"	1'-8"	1'-11"	2'-3"	2'-7"
Vert Bar-A				#4@24"	#4@24"	#4@16"	#4@24"	#4@24"	#4@16"	#4@24"
40 dia Lap				20"	20"	20"	20"	20"	20"	20"
Horiz Bars	#3@16"	#3@16"	#3@16"	#3@16"	#3@16"	#3@16"	#3@16"	#3@16"	#3@16"	#3@16"
Lower Bar-B	#3@24"	#3@24"	#3@24"	#4@24"	#4@24"	#5@16"	2'-0"	2'-8"	2'-8"	4'-0"
Min. Height of 12" Stem Wall										
Stem Bar-C										
Stem Horiz Bars										
Top Bar-D										
Footing Width-W	1'-6"	1'-11"	2'-3"	2'-7"	3'-1"	3'-11"	4'-5"	4'-11"	5'-7"	6'-3"
Footing Horiz Bars	3-#4	3-#4	3-#4	4-#4	4-#4	5-#4	5-#4	6-#4	7-#4	7-#4
Key to Toe				0'-11"	1'-2"	1'-2"	1'-8"	1'-11"	2'-3"	2'-7"
Key (w by d)	None	6" by 6"	12" by 8"	12" by 11"	12" by 15"	12" by 17"	12" by 21"	12" by 25"	12" by 29"	12" by 32"
Key Reinf							#4@16"	#4@16"	#4@16"	#4@16"

Variable heel (Minimum Toe), Level, 250 PSF Vehicular Surcharge

CV Wall	CWV250-14	CWV250-20	CWV250-28	CWV250-34	CWV250-40	CWV250-48	CWV250-54	CWV250-60	CWV250-68	CWV250-74
TYPE	I	I	I	I	I	I	I	I	I	I
Height -h	1'-4"	2'-0"	2'-8"	3'-4"	4'-0"	4'-8"	5'-4"	6'-0"	6'-8"	7'-4"
Slope/Surcharge	Level / 250	Level / 250	Level / 250	Level / 250	Level / 250	Level / 250	Level / 250	Level / 250	Level / 250	Level / 250
Block-t1	6"	6"	6"	8"	8"	8"	8"	8"	8"	8"
Stem Block										
Heel	0'-9"	1'-0"	1'-0"	1'-0"	1'-9"	1'-6"	1'-9"	1'-6"	2'-3"	2'-0"
Toe	0'-3"	0'-6"	0'-9"	1'-0"	1'-0"	1'-6"	1'-6"	2'-0"	2'-0"	2'-6"
Vert Bar-A				#4@24"	#4@24"	#4@24"	#4@24"	#4@24"	#4@24"	#4@24"
40 dia Lap				20"	20"	20"	20"	20"	20"	25"
Horiz Bars	#3@16"	#3@16"	#3@16"	#3@16"	#3@16"	#3@16"	#3@16"	#3@16"	#3@16"	#3@16"
Lower Bar-B	#3@24"	#3@24"	#4@16"	#4@24"	#5@16"	#5@8"	#4@24"	#4@16"	#4@24"	#5@16"
Min. Height of 12" Stem Wall										
Stem Bar-C										
Stem Horiz Bars										
Top Bar-D										
Footing Width-W	1'-6"	2'-0"	2'-3"	2'-8"	3'-5"	3'-8"	4'-3"	4'-6"	5'-3"	5'-6"
Footing Horiz Bars	3-#4	3-#4	3-#4	4-#4	4-#4	5-#4	5-#4	6-#4	7-#4	7-#4
Key to Toe	0'-6"	0'-10"	1'-0"	1'-3"	1'-2"	1'-6"	1'-11"	2'-3"	2'-3"	2'-9"
Key (w by d)	6" by 3"	8" by 5"	8" by 8"	12" by 11"	12" by 11"	12" by 15"	12" by 17"	12" by 21"	12" by 21"	12" by 25"
Key Reinf							#4@16"	#4@16"	#4@16"	#4@16"

REVISION	BY	APPROVED	DATE
ORIGINAL	CVM	C. SWANSON	12/01
REVISION	DPH	W. VALLE	11/17

CITY OF CHULA VISTA
 ENGINEERING & CAPITAL PROJECTS
 STANDARD DRAWING

TABLE FOR VAR. HEEL, 1.5-1
 SLOPE, 250 PSF, & SURCHARGE

William S. Valle
 WILLIAM S. VALLE 11/21/2017
 CITY ENGINEER

GRD-05

6-Inch heel, Level Backfill

CV Wall	CV6L-14	CV6L-20	CV6L-28	CV6L-34	CV6L-40	CV6L-48	CV6L-54	CV6L-60	CV6L-68	CV6L-74	CV6L-80
TYPE	I	I	I	I	I	I	I	I	I	I	I
Height -h	1'-4"	2'-0"	2'-8"	3'-4"	4'-0"	4'-8"	5'-4"	6'-0"	6'-8"	7'-4"	8'-0"
Slope	Level	Level	Level	Level	Level	Level	Level	Level	Level	Level	Level
Block-t1	6"	6"	6"	6"	8"	8"	8"	8"	8"	8"	8"
Stem Block											
Heel	0'-6"	0'-6"	0'-6"	0'-6"	0'-6"	0'-6"	0'-6"	0'-6"	0'-6"	0'-6"	0'-6"
Toe	0'-3"	0'-5"	0'-7"	1'-0"	0'-11"	1'-5"	1'-8"	2'-1"	2'-1"	2'-6"	2'-11"
Vert Bar-A				#3@24"	#4@24"	#4@24"	#4@24"	#4@24"	#4@24"	#4@24"	#4@24"
40 dia Lap				15"	20"	20"	20"	20"	20"	20"	20"
Horiz Bars	#3@16"	#3@16"	#3@16"	#3@16"	#3@16"	#3@16"	#3@16"	#3@16"	#3@16"	#3@16"	#3@16"
Lower Bar-B	#3@24"	#3@24"	#3@24"	#3@24"	#4@24"	#4@24"	#4@16"	#5@8"	#4@24"	#4@24"	#4@16"
Min. Height of 12" Stem Wall											
Stem Bar-C											
Stem Horiz Bars											
Top Bar-D											
Footing Width-W	1'-3"	1'-5"	1'-7"	2'-0"	2'-1"	2'-7"	2'-10"	3'-3"	3'-7"	4'-0"	4'-5"
Footing Horiz Bars	2-#4	2-#4	3-#4	3-#4	3-#4	4-#4	4-#4	4-#4	5-#4	5-#4	5-#4
Key to Toe			0'-9"	1'-0"	1'-2"	1'-3"	1'-6"	1'-9"	2'-1"	2'-6"	2'-9"
Key (w by d)	None	None	6" by 1"	6" by 4"	8" by 7"	12" by 12"	12" by 13"	12" by 16"	12" by 18"	12" by 21"	12" by 24"
Key Reinf								#4@16"	#4@16"	#4@16"	#4@16"

6-Inch heel, 2 to 1 Slope

CV Wall	CV620-14	CV620-20	CV620-28	CV620-34	CV620-40	CV620-48	CV620-54	CV620-60	CV620-68	CV620-74
TYPE	I	I	I	I	I	I	I	I	I	I
Height -h	1'-4"	2'-0"	2'-8"	3'-4"	4'-0"	4'-8"	5'-4"	6'-0"	6'-8"	7'-4"
Slope	2.0:1	2.0:1	2.0:1	2.0:1	2.0:1	2.0:1	2.0:1	2.0:1	2.0:1	2.0:1
Block-t1	6"	6"	6"	6"	8"	8"	8"	8"	8"	8"
Stem Block										
Heel	0'-6"	0'-6"	0'-6"	0'-6"	0'-6"	0'-6"	0'-6"	0'-6"	0'-6"	0'-6"
Toe	0'-4"	0'-6"	0'-9"	1'-2"	1'-4"	1'-10"	2'-2"	2'-3"	2'-10"	3'-3"
Vert Bar-A				#4@24"	#4@24"	#4@24"	#4@24"	#4@24"	#4@24"	#4@24"
40 dia Lap				20"	20"	20"	20"	20"	20"	20"
Horiz Bars	#3@16"	#3@16"	#3@16"	#3@16"	#3@16"	#3@16"	#3@16"	#3@16"	#3@16"	#3@16"
Lower Bar-B	#3@24"	#3@24"	#3@24"	#4@24"	#4@24"	#4@16"	#5@8"	#4@24"	#4@24"	#4@24"
Min. Height of 12" Stem Wall										
Stem Bar-C										
Stem Horiz Bars										
Top Bar-D										
Footing Width-W	1'-4"	1'-6"	1'-9"	2'-2"	2'-6"	3'-0"	3'-4"	3'-9"	4'-4"	4'-9"
Footing Horiz Bars	2-#4	3-#4	3-#4	3-#4	4-#4	4-#4	4-#4	5-#4	5-#4	6-#4
Key to Toe		0'-6"	0'-9"	0'-11"	1'-3"	1'-7"	2'-0"	2'-3"	2'-8"	3'-4"
Key (w by d)	None	6" by 4"	8" by 8"	12" by 11"	12" by 14"	12" by 18"	12" by 22"	12" by 25"	12" by 28"	12" by 32"
Key Reinf							#4@16"	#4@16"	#4@16"	#4@16"

REVISION	BY	APPROVED	DATE
ORIGINAL	CVM	C. SWANSON	12/01
REVISION	DPH	W. VALLE	11/17

CITY OF CHULA VISTA
 ENGINEERING & CAPITAL PROJECTS
 STANDARD DRAWING

TABLE FOR 6-IN HEEL, LEVEL
 BACKFILL, & 2 TO 1 SLOPE

Williams, Valle
 WILLIAM S. VALLE 11/21/2017
 CITY ENGINEER

GRD-05

6-inch heel, 1.5 to 1 Slope

CV Wall	CV615-14	CV615-20	CV615-28	CV615-34	CV615-40	CV615-48	CV615-54	CV615-60	CV615-68	CV615-74
TYPE	I	I	I	I	I	I	II	II	II	II
Height -h	1'-4"	2'-0"	2'-8"	3'-4"	4'-0"	4'-8"	5'-4"	6'-0"	6'-8"	7'-4"
Slope	1.5:1	1.5:1	1.5:1	1.5:1	1.5:1	1.5:1	8"	8"	8"	8"
Block-t1	6"	6"	6"	8"	8"	8"	12"	12"	12"	12"
Stem Block										
Heel	0'-6"	0'-6"	0'-6"	0'-6"	0'-6"	0'-6"	0'-6"	0'-6"	0'-6"	0'-6"
Toe	0'-6"	1'-0"	1'-8"	1'-4"	1'-8"	2'-1"	2'-4"	2'-9"	3'-3"	3'-9"
Vert. Bar-A				#4@24"	#4@24"	#4@16"	#4@24"	#4@24"	#4@24"	#4@24"
40 dia Lap				20"	20"	20"	20"	20"	20"	20"
Horiz Bars	#3@16"	#3@16"	#3@16"	#3@16"	#3@16"	#3@16"	#3@16"	#3@16"	#3@16"	#3@16"
Lower Bar-B	#3@24"	#3@24"	#3@24"	#4@24"	#4@24"	#5@16"	#4@24"	#4@24"	#4@24"	#4@24"
Min. Height of 12" Stem Wall							2'-0"	2'-5"	2'-8"	4'-0"
Stem Bar-C							#4@16"	#5@16"	#5@8"	#8@8"
Stem Horiz Bars							#4@16"	#4@16"	#4@16"	#4@16"
Top Bar-D										
Footing Width-W	1'-6"	2'-0"	2'-8"	2'-6"	2'-10"	3'-3"	3'-10"	4'-3"	4'-9"	5'-3"
Footing Horiz Bars	3-#4	3-#4	4-#4	4-#4	4-#4	4-#4	5-#4	5-#4	6-#4	6-#4
Key to Toe		0'-6"	1'-0"	1'-0"	1'-6"	1'-11"	2'-4"	2'-9"	3'-3"	3'-9"
Key (w by d)	None	6" by 4"	8" by 10"	12" by 12"	12" by 17"	12" by 21"	12" by 25"	12" by 30"	12" by 34"	12" by 38"
Key Reinf						#4@16"	#4@16"	#4@16"	#4@16"	#4@16"

6-inch heel, Level Backfill, 250 PSF Vehicular Surcharge

CV Wall	CV6S-14	CV6S-20	CV6S-28	CV6S-34	CV6S-40	CV6S-48	CV6S-54	CV6S-60	CV6S-68	CV6S-74
TYPE	I	I	I	I	I	I	II	II	II	II
Height -h	1'-4"	2'-0"	2'-8"	3'-4"	4'-0"	4'-8"	5'-4"	6'-0"	6'-8"	7'-4"
Slope/Surcharge	Level / 250	Level / 250	Level / 250	Level / 250	Level / 250	Level / 250	Level / 250	Level / 250	Level / 250	Level / 250
Block-t1	6"	6"	6"	8"	8"	8"	8"	8"	8"	8"
Stem Block										
Heel	0'-6"	0'-6"	0'-6"	0'-6"	0'-6"	0'-6"	0'-6"	0'-6"	0'-6"	0'-6"
Toe	0'-8"	1'-0"	1'-5"	1'-5"	1'-10"	2'-4"	2'-3"	2'-9"	3'-2"	3'-9"
Vert. Bar-A				#4@24"	#4@24"	#4@24"	#4@24"	#4@24"	#4@24"	#4@24"
40 dia Lap				20"	20"	20"	20"	25"	20"	25"
Horiz Bars	#3@16"	#3@16"	#3@16"	#3@16"	#3@16"	#3@16"	#3@16"	#3@16"	#3@16"	#3@16"
Lower Bar-B	#3@24"	#3@24"	#4@16"	#4@24"	#5@16"	#5@8"	#4@24"	#5@24"	#4@24"	#5@16"
Min. Height of 12" Stem Wall							2'-0"	2'-8"	3'-4"	4'-0"
Stem Bar-C							#4@16"	#5@16"	#6@8"	#8@8"
Stem Horiz Bars							#4@16"	#4@16"	#4@16"	#4@16"
Top Bar-D										
Footing Width-W	1'-8"	2'-0"	2'-5"	2'-8"	3'-0"	3'-6"	3'-9"	4'-3"	4'-8"	5'-3"
Footing Horiz Bars	2-#4	3-#4	3-#4	3-#4	4-#4	4-#4	4-#4	5-#4	5-#4	6-#4
Key to Toe	0'-9"	2'-0"	2'-5"	2'-8"	3'-0"	3'-6"	3'-9"	4'-3"	4'-8"	5'-3"
Key (w by d)	6" by 4"	8" by 7"	8" by 10"	12" by 13"	12" by 16"	12" by 19"	12" by 22"	12" by 25"	12" by 28"	12" by 31"
Key Reinf						#4@16"	#4@16"	#4@16"	#4@16"	#4@16"

REVISION	BY	APPROVED	DATE
ORIGINAL	CVM	C. SWANSON	12/01
REVISION	DPH	W. VALLE	11/17

CITY OF CHULA VISTA
 ENGINEERING & CAPITAL PROJECTS
 STANDARD DRAWING

TABLE FOR 6-IN HEEL, 1.5 TO 1
 SLOPE, 250 PSF, & SURCHARGE

William S. Valle
 WILLIAM S. VALLE 11/21/2017
 CITY ENGINEER

GRD-05

2-inch heel, Level Backfill

CV Wall	CV2L-14	CV2L-20	CV2L-28	CV2L-34	CV2L-40	CV2L-48	CV2L-54	CV2L-60	CV2L-68	CV2L-74	CV2L-80
TYPE	I	I	I	I	I	I	I	I	I	I	I
Height -h	1'-4"	2'-0"	2'-8"	3'-4"	4'-0"	4'-8"	5'-4"	6'-0"	6'-8"	7'-4"	8'-0"
Slope	Level	Level	Level	Level	Level	Level	Level	Level	Level	Level	Level
Block-t1	6"	6"	6"	6"	8"	8"	8"	8"	8"	8"	8"
Stem Block											
Heel	0'-2"	0'-2"	0'-2"	0'-2"	0'-2"	0'-2"	0'-2"	0'-2"	0'-2"	0'-2"	0'-2"
Toe	0'-4"	0'-8"	1'-1"	1'-3"	1'-5"	1'-8"	2'-2"	2'-4"	2'-4"	2'-8"	3'-4"
Vert Bar-A				#3@24"	#4@24"	#4@24"	#4@24"	#4@24"	#4@24"	#4@24"	#4@24"
40 dia Lap				15"	20"	20"	20"	20"	20"	20"	20"
Horiz Bars	#3@16"	#3@16"	#3@16"	#3@16"	#3@16"	#3@16"	#3@16"	#3@16"	#3@16"	#3@16"	#3@16"
Lower Bar-B	#3@24"	#3@24"	#3@24"	#3@16"	#4@24"	#4@24"	#4@16"	#5@8"	#4@24"	#4@24"	#4@16"
Min. Height of 12" Stem Wall											
Stem Bar-C									#5@24"	#5@16"	#5@8"
Stem Horiz Bars									#4@16"	#4@16"	#4@16"
Top Bar-D											
Footing Width-W	1'-0"	1'-4"	1'-9"	2'-0"	2'-3"	2'-6"	3'-0"	3'-4"	3'-6"	3'-11"	4'-6"
Footing Horiz Bars	2-#4	2-#4	3-#4	3-#4	4-#4	4-#4	4-#4	4-#4	5-#4	5-#4	6-#4
Key to Toe			1'-0"	1'-1"	1'-2"	1'-0"	1'-5"	1'-9"	2'-2"	2'-6"	2'-6"
Key (w by d)	None	None	6" by 2"	6" by 6"	8" by 8"	12" by 11"	12" by 14"	12" by 17"	12" by 19"	12" by 22"	12" by 26"
Key Reinf									#4@16"	#4@16"	#4@16"

2-inch heel, 2 to 1 Slope

CV Wall	CV220-14	CV220-20	CV220-28	CV220-34	CV220-40	CV220-48	CV220-54	CV220-60	CV220-68	CV220-74
TYPE	I	I	I	I	I	I	I	I	I	I
Height -h	1'-4"	2'-0"	2'-8"	3'-4"	4'-0"	4'-8"	5'-4"	6'-0"	6'-8"	7'-4"
Slope	2:0:1	2:0:1	2:0:1	2:0:1	2:0:1	2:0:1	2:0:1	2:0:1	2:0:1	2:0:1
Block-t1	6"	6"	6"	8"	8"	8"	8"	8"	8"	8"
Stem Block										
Heel	0'-2"	0'-2"	0'-2"	0'-2"	0'-2"	0'-2"	0'-2"	0'-2"	0'-2"	0'-2"
Toe	0'-7"	0'-8"	1'-1"	1'-4"	1'-8"	2'-0"	2'-5"	2'-5"	2'-11"	3'-4"
Vert Bar-A				#4@24"	#4@24"	#4@24"	#4@24"	#4@24"	#4@24"	#4@24"
40 dia Lap				20"	20"	20"	20"	20"	20"	20"
Horiz Bars	#3@16"	#3@16"	#3@16"	#3@16"	#3@16"	#3@16"	#3@16"	#3@16"	#3@16"	#3@16"
Lower Bar-B	#3@24"	#3@24"	#3@24"	#4@24"	#4@24"	#4@16"	#5@8"	#4@24"	#4@24"	#4@24"
Min. Height of 12" Stem Wall										
Stem Bar-C								#5@24"	#6@16"	#6@8"
Stem Horiz Bars								#4@16"	#4@16"	#4@16"
Top Bar-D										
Footing Width-W	1'-3"	1'-4"	1'-9"	2'-0"	2'-6"	2'-10"	3'-3"	3'-7"	4'-1"	4'-6"
Footing Horiz Bars	2-#4	2-#4	3-#4	3-#4	3-#4	4-#4	4-#4	5-#4	5-#4	6-#4
Key to Toe		0'-7"	1'-0"	0'-11"	1'-3"	1'-7"	2'-0"	2'-5"	2'-11"	3'-4"
Key (w by d)	None	6" by 6"	8" by 8"	12" by 12"	12" by 14"	12" by 18"	12" by 22"	12" by 25"	12" by 28"	12" by 32"
Key Reinf							#4@16"	#4@16"	#4@16"	#4@16"

REVISION	BY	APPROVED	DATE
ORIGINAL	CVM	C. SWANSON	12/01
REVISION	DPH	W. VALLE	11/17

CITY OF CHULA VISTA
 ENGINEERING & CAPITAL PROJECTS
 STANDARD DRAWING

TABLE FOR 2-IN HEEL, LEVEL
 BACKFILL, & 2 TO 1 SLOPE

W. Valle
 WILLIAM S. VALLE
 CITY ENGINEER

11/21/2017

GRD-05

2-inch heel, 1.5 to 1 Slope

CV Wall	CV215-14	CV215-20	CV215-28	CV215-34	CV215-40	CV215-48	CV215-54	CV215-60	CV215-68	CV215-74
TYPE	I	I	I	I	I	I	II	II	II	II
Height -h	1'-4"	2'-0"	2'-8"	3'-4"	4'-0"	4'-8"	5'-4"	6'-0"	6'-8"	7'-4"
Slope	1.5:1	1.5:1	1.5:1	1.5:1	1.5:1	1.5:1	1.5:1	1.5:1	1.5:1	1.5:1
Block-t1	6"	6"	6"	8"	8"	8"	8"	8"	8"	8"
Stem Block										
Heel	0'-2"	0'-2"	0'-2"	0'-2"	0'-2"	0'-2"	0'-2"	0'-2"	0'-2"	0'-2"
Toe	1'-2"	1'-4"	1'-6"	1'-9"	2'-4"	2'-9"	3'-0"	3'-3"	3'-10"	5'-0"
Vert Bar-A				#4@24"	#4@24"	#4@16"	#4@24"	#4@16"	#4@16"	#4@16"
40 dia Lap				20"	20"	20"	20"	20"	20"	20"
Horiz Bars	#3@16"	#3@16"	#3@16"	#3@16"	#3@16"	#3@16"	#3@16"	#3@16"	#3@16"	#3@16"
Lower Bar-B	#3@24"	#3@24"	#3@24"	#4@24"	#4@24"	#5@8"	#4@24"	#4@16"	#4@16"	#4@16"
Min. Height of 12" Stem Wall										
Stem Bar-C										
Stem Horiz Bars										
Top Bar-D										
Footing Width-W	1'-10"	2'-0"	2'-2"	2'-7"	3'-2"	3'-7"	4'-0"	4'-5"	5'-0"	6'-2"
Footing Horiz Bars	3-#4	3-#4	3-#4	4-#4	4-#4	4-#4	5-#4	5-#4	6-#4	7-#4
Key to Toe		1'-4"	1'-2"	1'-7"	2'-2"	2'-7"	3'-2"	3'-5"	3'-10"	5'-0"
Key (w by d)	None	4" by 6"	12" by 9"	12" by 13"	12" by 17"	12" by 22"	12" by 26"	12" by 30"	12" by 34"	12" by 38"
Key Reinf						#4@16"	#4@16"	#4@16"	#4@16"	#4@16"

2-inch heel, Level Backfill, 250 PSF Vehicular Surcharge

CV Wall	CV2S-14	CV2S-20	CV2S-28	CV2S-34	CV2S-40	CV2S-48	CV2S-54	CV2S-60	CV2S-68	CV2S-74
TYPE	I	I	I	I	I	I	II	II	II	II
Height -h	1'-4"	2'-0"	2'-8"	3'-4"	4'-0"	4'-8"	5'-4"	6'-0"	6'-8"	7'-4"
Slope/Surcharge	Level / 250	Level / 250	Level / 250	Level / 250	Level / 250	Level / 250	Level / 250	Level / 250	Level / 250	Level / 250
Block-t1	6"	6"	8"	8"	8"	8"	8"	8"	8"	8"
Stem Block										
Heel	0'-2"	0'-2"	0'-2"	0'-2"	0'-2"	0'-2"	0'-2"	0'-2"	0'-2"	0'-2"
Toe	1'-4"	1'-9"	2'-2"	2'-3"	2'-10"	3'-2"	2'-8"	3'-1"	3'-8"	4'-0"
Vert Bar-A				#4@24"	#4@24"	#4@24"	#4@24"	#4@24"	#4@24"	#4@24"
40 dia Lap				20"	20"	20"	20"	25"	20"	25"
Horiz Bars	#3@16"	#3@16"	#3@16"	#3@16"	#3@16"	#3@16"	#3@16"	#3@16"	#3@16"	#3@16"
Lower Bar-B	#3@24"	#3@24"	#4@24"	#4@24"	#5@16"	#6@8"	#4@24"	#5@16"	#4@24"	#5@16"
Min. Height of 12" Stem Wall										
Stem Bar-C										
Stem Horiz Bars										
Top Bar-D										
Footing Width-W	2'-0"	2'-5"	2'-10"	3'-1"	3'-8"	4'-0"	3'-10"	4'-4"	4'-10"	5'-2"
Footing Horiz Bars	3-#4	3-#4	4-#4	4-#4	4-#4	5-#4	5-#4	5-#4	6-#4	6-#4
Key to Toe	1'-0"	1'-4"	1'-3"	1'-6"	1'-11"	2'-3"	2'-8"	3'-0"	3'-8"	4'-0"
Key (w by d)	6" by 4"	8" by 8"	12" by 11"	12" by 14"	12" by 17"	12" by 20"	12" by 23"	12" by 26"	12" by 30"	12" by 34"
Key Reinf						#4@16"	#4@16"	#4@16"	#4@16"	#4@16"

REVISION	BY	APPROVED	DATE
ORIGINAL	CVM	C. SWANSON	12/01
REVISION	DPH	W. VALLE	11/17

CITY OF CHULA VISTA
 ENGINEERING & CAPITAL PROJECTS
 STANDARD DRAWING
 TABLE FOR 2-IN HEEL, 1.5 TO 1
 SLOPE, 250 PSF & SURCHARGE

William S. Valle
 WILLIAM S. VALLE 11/21/2017
 CITY ENGINEER
 GRD-05

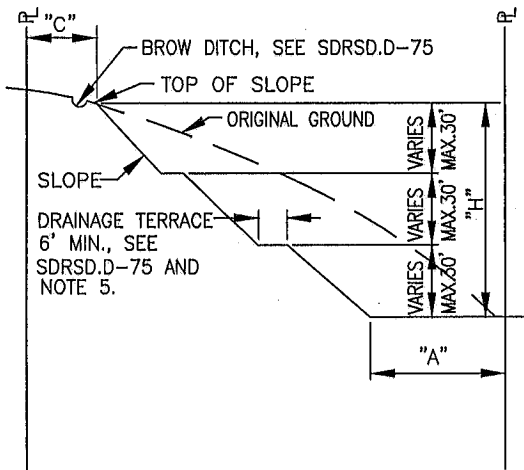

PROFILE-TYPICAL CUT SLOPE

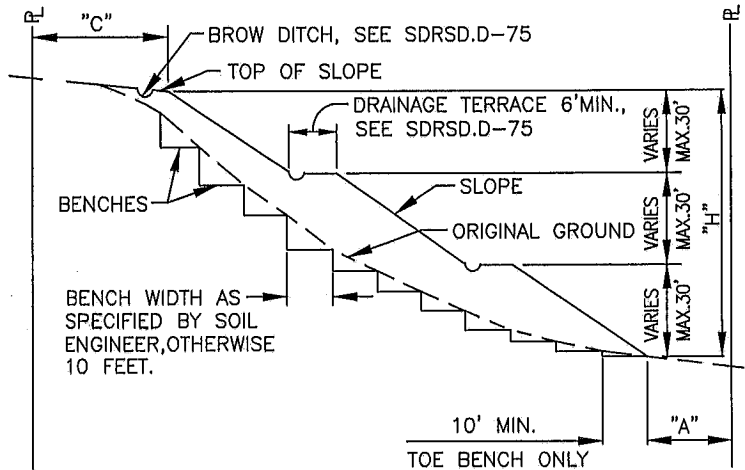

PROFILE-TYPICAL FILL SLOPE

H = VERTICAL HEIGHT OF SLOPE.

A = DISTANCE TOE OF SLOPE TO OUTER BOUNDARIES OF THE PERMIT AREA, INCLUDING SLOPE RIGHT AREAS AND EASEMENTS.

C = DISTANCE TOP OF SLOPE TO OUTER BOUNDARIES OF THE PERMIT AREA, INCLUDING SLOPE RIGHT AREAS AND EASEMENTS. WHERE BROW DITCH IS TO BE CONSTRUCTED "C" DISTANCE MUST BE A MINIMUM OF 3 FEET.

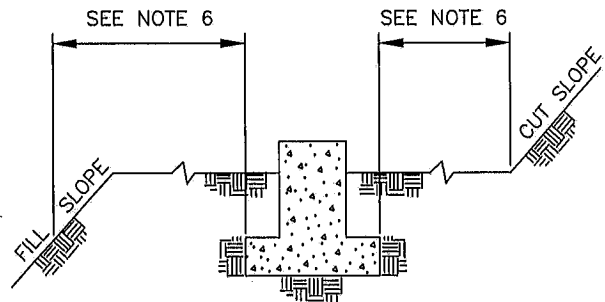

BUILDING FOUNDATION
CLEARANCE
CUT/FILL SLOPE

HEIGHT OF CUT/FILL	REQUIRED SETBACKS FROM CUT/FILL SLOPES	
H	A	C
0 - 5'	1 - 6'	1'
5' - 30'	H/2	H/5
OVER 30'	15'	6'

NOTES:

1. GRADING SHALL BE DONE IN ACCORDANCE WITH THE PROVISIONS OF THE GRADING ORDINANCE AND GRADING PERMIT.
2. SLOPE RATIOS SHALL NOT BE STEEPER THAN 2:1 CUTS AND FILLS.
3. LANDSCAPING AND IRRIGATION SHALL BE DONE IN ACCORDANCE WITH CITY LANDSCAPE MANUAL.
4. FENCING SHALL BE INSTALLED AS DIRECTED BY CITY ENGINEER.
5. SLOPE TERRACES ARE OPTIONAL UNLESS DIRECTED BY SOILS ENGINEER.
6. SEE SOILS REPORT, ZONING & BUILDING CODE REQUIREMENTS FOR LOCATION OF FOOTINGS.

REVISION	BY	APPROVED	DATE
ORIGINAL			1/95
REVISION	CVM	C. SWANSON	4/02
REVISION	DPH	W. VALLE	11/17

CITY OF CHULA VISTA
ENGINEERING & CAPITAL PROJECTS
STANDARD DRAWING

William S. Valle
WILLIAM S. VALLE 11/21/2017
CITY ENGINEER

GRADED SLOPES

GRD-06

GENERAL SURFACE IMPROVEMENTS (GSI)



**DESIGN AND
CONSTRUCTION
STANDARD DRAWINGS
2017**

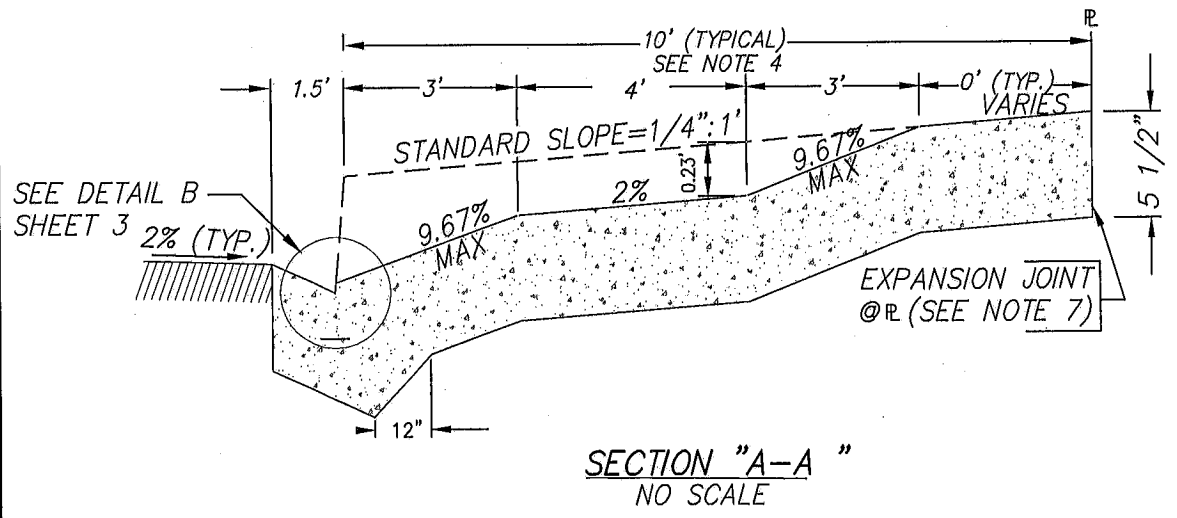
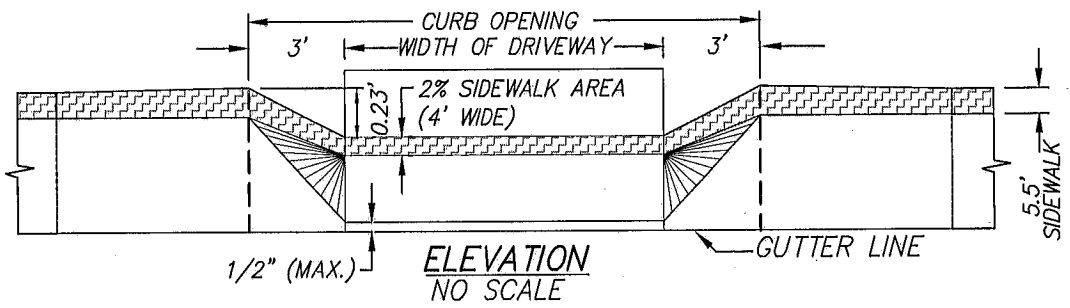
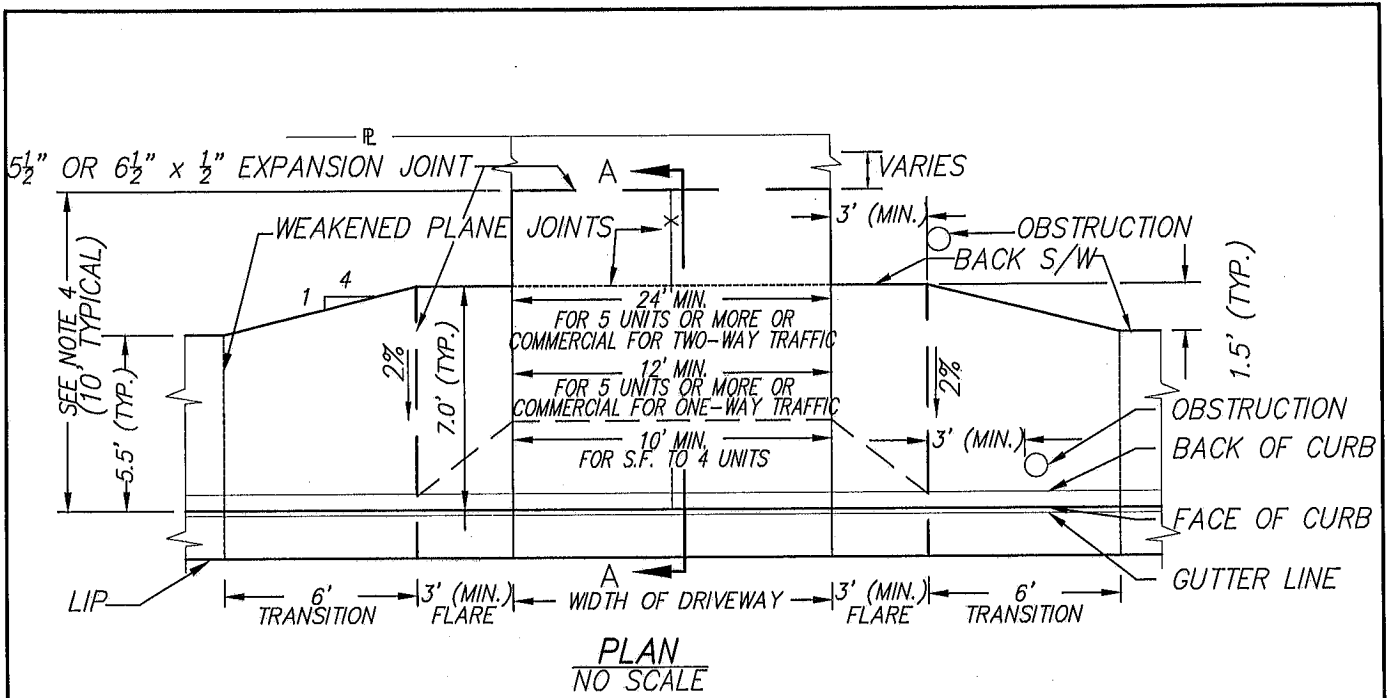

SHEET 1 OF 3

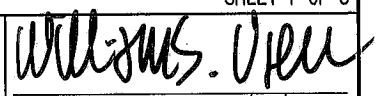
REVISION	BY	APPROVED	DATE	CITY OF CHULA VISTA ENGINEERING & CAPITAL PROJECTS STANDARD DRAWING	 WILLIAM S. VALLE CITY ENGINEER
ORIGINAL			7/75		
REVISION	CVM	C. SWANSON	11/02		
REVISION	DPH	W. VALLE	11/17		
DRIVEWAY WITH MONOLITHIC CURB, GUTTER, AND SIDEWALK				GSI-01	

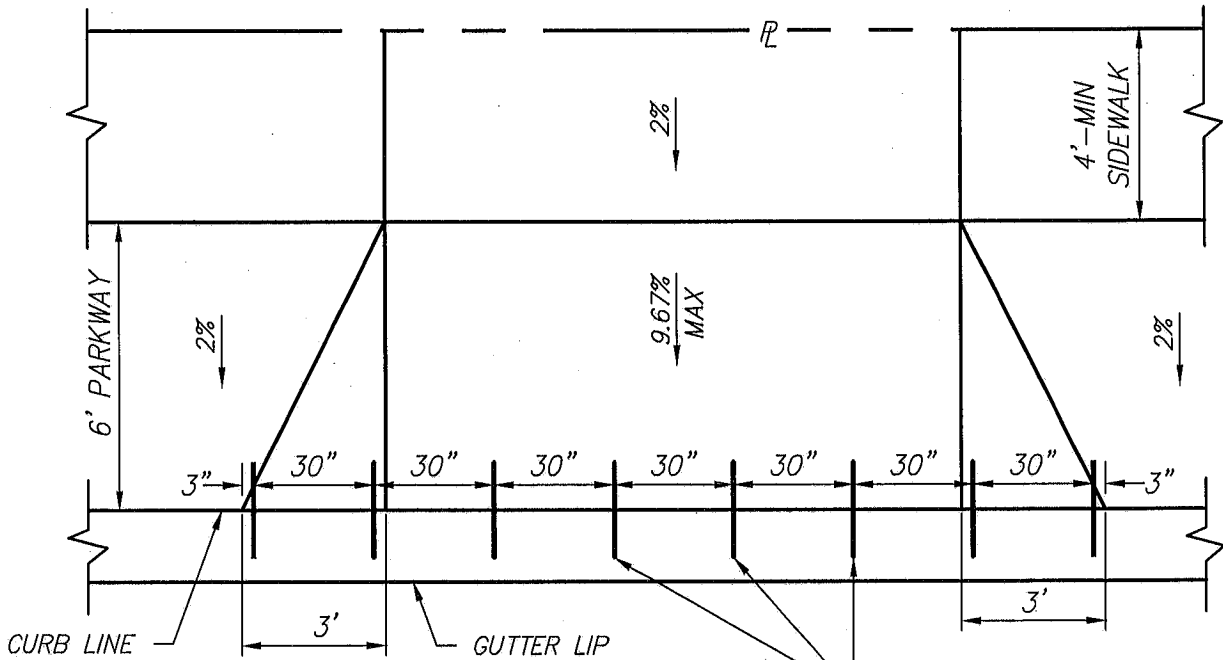

PLAN

24" TIE BAR WITH REBAR @ 30" O.C.

10' (TYPICAL)

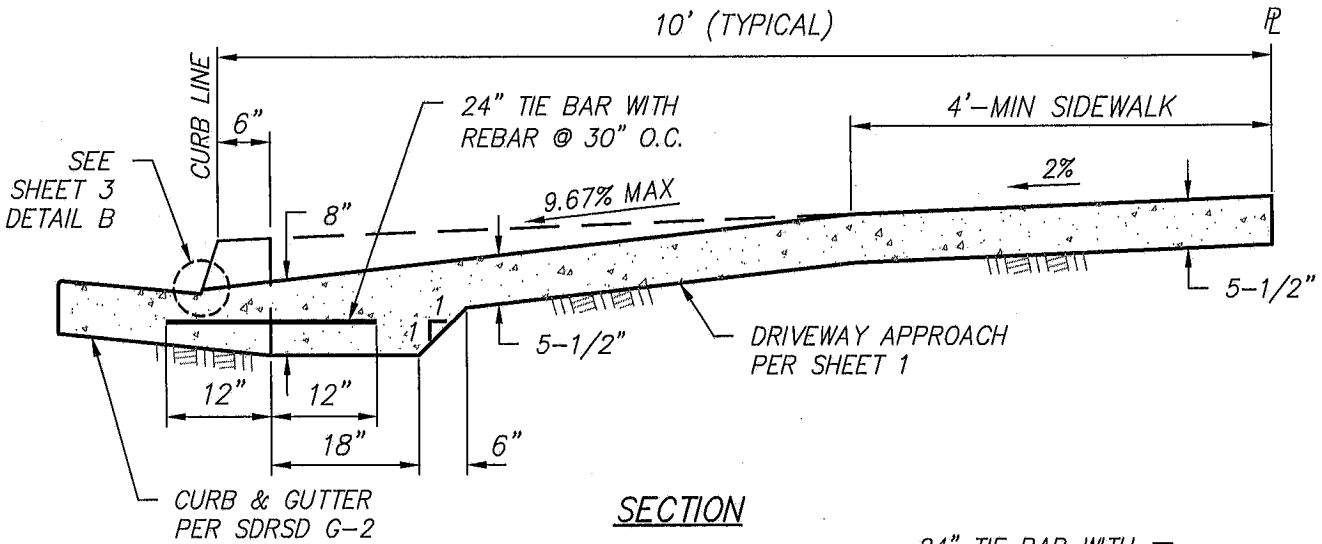

SECTION

24" TIE BAR WITH REBAR @ 30" O.C.

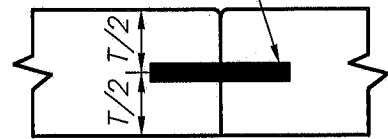

CONCRETE JOINT DETAIL

NOTE:

TIE BARS SHALL BE CAST IN CONCRETE AND HELD IN POSITION BY MEANS APPROVED BY THE INSPECTOR OR TIE BARS MAY BE INSTALLED BY DRILLING AND BONDING WITH AN APPROVED EPOXY ADHESIVE. (EPOXY ADHESIVE SHALL HAVE A MINIMUM BOND STRENGTH IN 1 DAY EQUAL TO 2000 PSI. DRILL BIT SHALL EQUAL BAR DIAMETER PLUS 1/8".)

FOR ADDITIONAL NOTES AND SPECIFICATIONS, SEE SHEET 3.

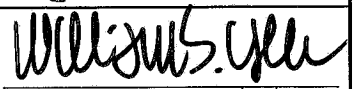
REVISION	BY	APPROVED	DATE	CITY OF CHULA VISTA ENGINEERING & CAPITAL PROJECTS STANDARD DRAWING	 WILLIAM S. VALLE CITY ENGINEER
ORIGINAL			3/99		
REVISION	CVM	C. SWANSON	11/02		
REVISION	DPH	W. VALLE	11/17		
				DRIVEWAY WITH NON-CONTIGUOUS SIDEWALK	GSI-01

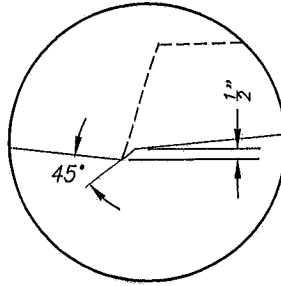

DETAIL B:
NO SCALE

GENERAL NOTES:

1. THIS STANDARD SHALL GOVERN THE CONSTRUCTION OF ALL DRIVEWAYS.
2. CURB OPENINGS PER LOT:
SINGLE FAMILY RESIDENTIAL – 16’ MIN., 25’ MAX. A MAXIMUM OF 40% FRONTAGE FOR CURB OPENINGS, UNLESS OTHERWISE APPROVED BY THE CITY ENGINEER.
MULTI-RESIDENTIAL & COMMERCIAL – 16’ MIN., 35’ MAX. A MAXIMUM OF 60% FRONTAGE FOR CURB OPENINGS, UNLESS OTHERWISE APPROVED BY THE CITY ENGINEER.
3. BOTH RESIDENTIAL & COMMERCIAL CURB OPENING SHALL BE A MINIMUM OF 8’ FROM ANY P.C.R., AND 3’ FROM ANY OBSTRUCTION, I.E. POLES, HYDRANTS, ETC., UNLESS OTHERWISE APPROVED.
4. THE MINIMUM DISTANCE SHALL BE 10’ OR TO PROPERTY LINE WHICH EVER IS LESS.
5. FOR CONCRETE JOIN DETAILS SEE STANDARDS SSM.
6. ALL CONCRETE SHALL BE 517-C-2500 EXCEPT FOR COMMERCIAL DRIVEWAYS.
7. IF PROPERTY LINE IS LESS THAN 10’ FROM FACE OF CURB, PLACE EXPANSION JOINT AT PROPERTY LINE.
8. FOR COMMERCIAL DRIVEWAYS, CONCRETE SHALL BE 560-C-3250 IN CURB OPENING AREA. WHERE THE R-VALUE IS LESS THAN 40, THE THICKNESS SHALL BE INCREASED TO 6½” FOR COMMERCIAL DRIVEWAYS ONLY.
- *9. ADDITIONAL WEAKENED PLANE JOINTS ARE REQUIRED WHEN THE WIDTH OF DRIVEWAY EXCEEDS 18’. THE NUMBER OF ADDITIONAL WEAKENED PLANE JOINTS ARE DETERMINED AS FOLLOWS: DIVIDE THE WIDTH OF THE DRIVEWAY BY 1.5 TIMES THE DEPTH (NORMALLY 10’). E.G. 25/1.5 X 10 = 1.67. LESS THAN 2, THEREFORE USE 1 JOINT.
10. NOT TO BE USED WHEN CURB EXCEEDS 6’

REVISION	BY	APPROVED	DATE	CITY OF CHULA VISTA ENGINEERING & CAPITAL PROJECTS STANDARD DRAWING	 WILLIAM S. VALLE 11/21/2017 CITY ENGINEER
ORIGINAL			7/75		
REVISION	CVM	C. SWANSON	11/02		
REVISION	DPH	W. VALLE	11/17		
				DRIVEWAY NOTES	GSI-01

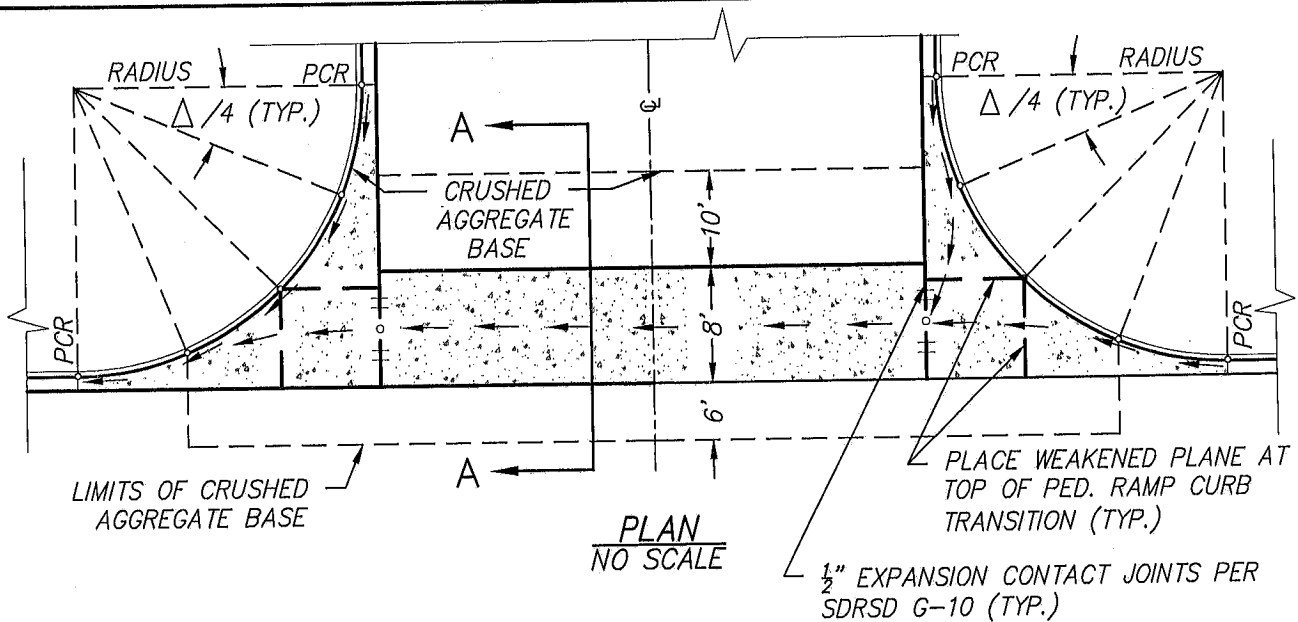

PLAN
NO SCALE

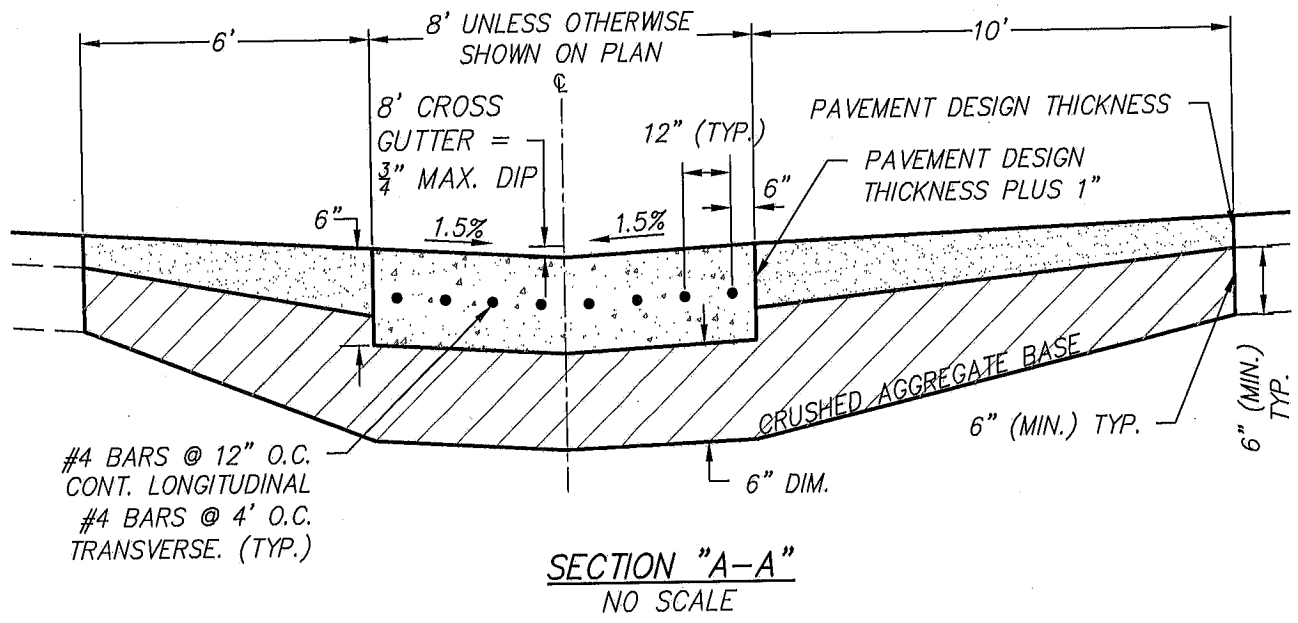

SECTION "A-A"
NO SCALE

NOTES:

1. ALL CONCRETE TO BE 560-C-3250.
2. — — — — = HORIZONTAL LIMITS OF CRUSHED AGGREGATE BASE. TO BE A MINIMUM OF 6" THICK UNDER CROSS GUTTER AND RETURN SEGMENTS (SPANDRELS), COMPACTED TO 95%.
3. RETURN SEGMENTS TO HAVE 6" X 6", 10 GAGE WIRE MESH (#4 REBAR @ 12" O.C. BOTH WAYS MAY BE SUBSTITUTED).
4. — — — — = WEAKENED PLANE JOINTS. OTHER EXPANSION JOINTS AND WEAKENED PLANE JOINTS FOR SIDEWALKS, CURB AND GUTTER PER
5. ← ← = TYPICAL FLOWLINES.
6. ○ = ELEVATIONS TO BE SHOWN ON PLANS.
7. RETURN SEGMENTS TO BE 6" THICK.
8. PLACE WEAKEN PLANE JOINT PER AT TOP OF PEDESTRIAN RAMP CURB TRANSITION.

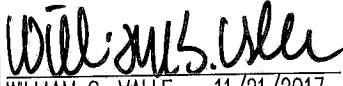
REVISION	BY	APPROVED	DATE	CITY OF CHULA VISTA ENGINEERING & CAPITAL PROJECTS STANDARD DRAWING	 WILLIAM S. VALLE CITY ENGINEER
ORIGINAL			7/75		
REVISION	CVM	C. SWANSON	11/02		
REVISION	DPH	W. VALLE	11/17		
CROSS GUTTER				GSI-02	

EXISTING CROSS GUTTER

24" TIE BAR, #4 REBAR
@ 30" O.C.

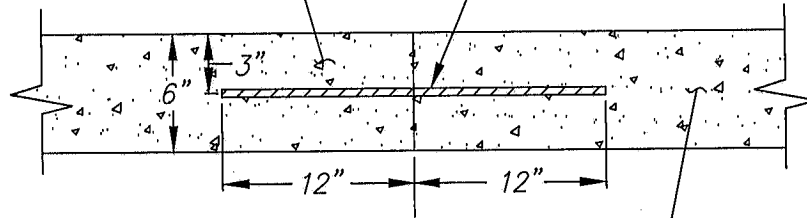

PORTION OF EXIST. CROSS GUTTER
TO BE REMOVED AND REPLACED

NOTE: TIE BARS SHALL BE INSTALLED BY DRILLING AND BONDING WITH AN APPROVED EPOXY ADHESIVE. (EPOXY ADHESIVE SHALL HAVE A MINIMUM BOND STRENGTH IN ONE (1) DAY EQUAL TO 2000 PSI. DRILL BIT SHALL EQUAL BAR DIAMETER PLUS 1/8".) DRILL AND SET TIE BARS IN EXISTING CONCRETE WHEN CONNECTING TO NEW CONCRETE.

SHEET 2 OF 2

REVISION	BY	APPROVED	DATE	CITY OF CHULA VISTA ENGINEERING & CAPITAL PROJECTS STANDARD DRAWING	<i>William S. Valle</i> WILLIAM S. VALLE 11/21/2017 CITY ENGINEER
ORIGINAL			7/75		
REVISION	CVM	C. SWANSON	11/02	CROSS GUTTER DOWEL CONNECTIONS	GSI-02
REVISION	DPH	W. VALLE	11/17		

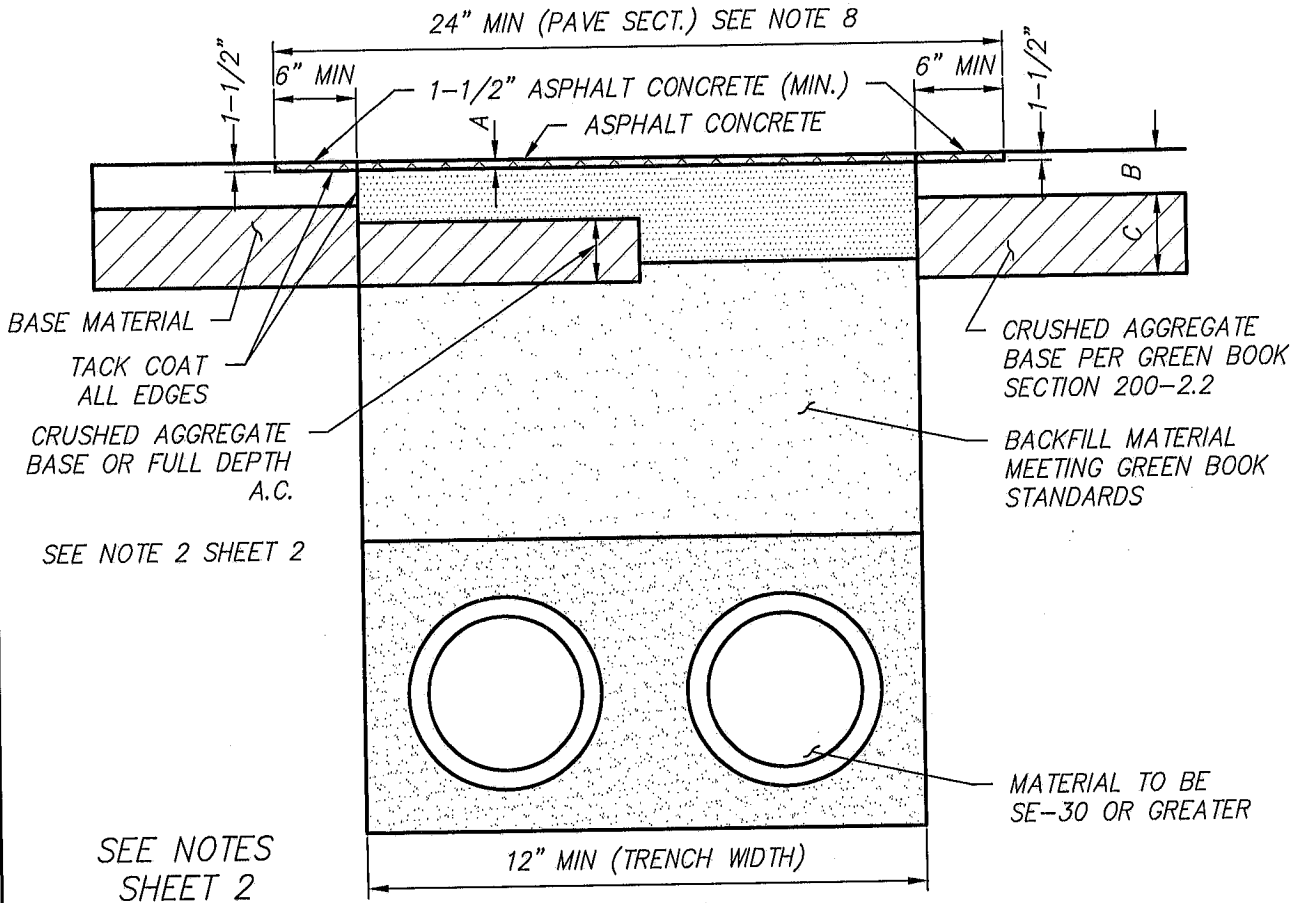

TYPE 'J'

SEE NOTES SHEET 2

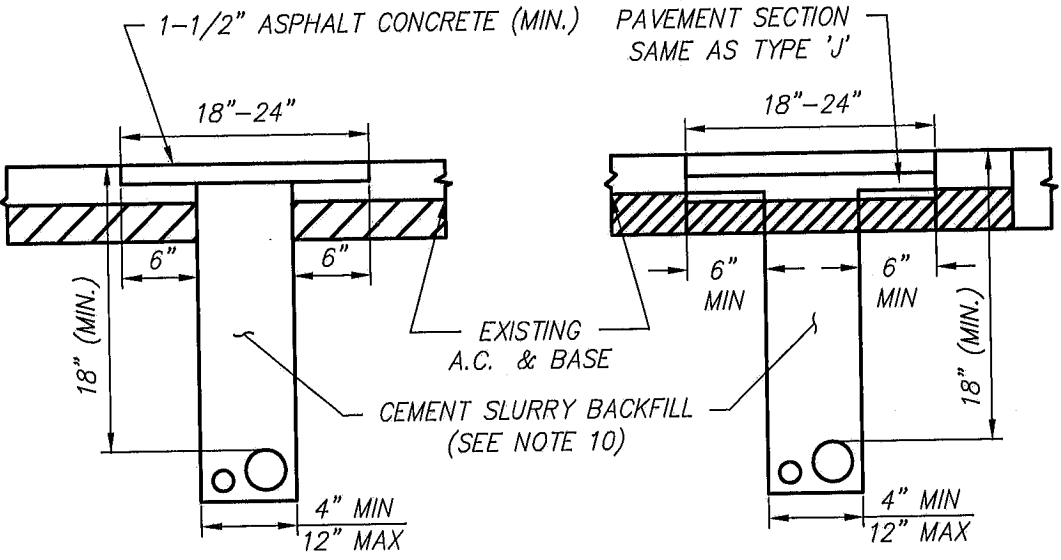

TYPE '1'-(1)'

TYPE '1'-(2)'

REVISION	BY	APPROVED	DATE
ORIGINAL			2/90
REVISION	CVM	A. AGHA	1/04
REVISION	DPH	W. VALLE	11/17

CITY OF CHULA VISTA
 ENGINEERING & CAPITAL PROJECTS
 STANDARD DRAWING
 TRENCH BACKFILL TYPE I AND J

William S. Valle
 WILLIAM S. VALLE 11/21/2017
 CITY ENGINEER
 GSI-03

NOTES:

1. EXISTING ASPHALT SHALL BE CUT AND REMOVED IN SUCH A MANNER SO AS NOT TO TEAR, BULGE, OR DISPLACE ADJACENT PAVEMENT. EDGES SHALL BE CLEAN AND VERTICAL. ALL CUTS SHALL BE PARALLEL OR PERPENDICULAR TO STREET CENTERLINE, WHEN PRACTICAL.
2. THE REMOVED PAVEMENT SECTION SHALL BE REPLACED WITH BASE MATERIAL AND ASPHALT CONCRETE. THE MINIMUM THICKNESS OF THE REPLACEMENT ASPHALT CONCRETE (A) SHALL BE: $A=(B+1")$
 REPLACEMENT BASE SHALL BE CRUSHED AGGREGATE BASE 4" MIN. THICK.
 IF AGGREGATE BASE IS TO BE REPLACED WITH ASPHALT CONCRETE, THEN THE MINIMUM THICKNESS OF THE ASPHALT CONCRETE SHALL BE:
 ON COMPACTED FILL - $A=(B+1") + (C/2)$
 ON SLURRY BACKFILL - $A=(B+1") + (2C/3)$
 (SEE SLURRY REQUIREMENTS BELOW)
 IF CEMENT TREATED BASE - $A=(B+1") + (2C/3)$
3. A TACK COAT OF EMULSIFIED ASPHALT (SS-1H OR RS-1) SHALL BE APPLIED TO ALL SURFACES WHICH WILL BE IN CONTACT WITH THE REPLACEMENT ASPHALT CONCRETE.
4. THE FINISH COURSE FOR RESURFACING SHALL BE LAID DOWN USING A SPREADER BOX. ALL RESURFACING SHALL BE SEAL COATED WITH AN EMULSIFIED ASPHALT AND COVERED WITH SAND. *CHIP SEALING SHALL BE APPLIED AS REQUIRED BY THE CITY.
5. ASPHALT CONCRETE RESURFACING TO BE TYPE III, C-3 AR4000 FOR TOP COURSE (4" MAX. THICKNESS), ($\frac{1}{2}$ " AGGREGATE). IF GREATER THAN 4", USE 2 OR MORE LIFTS. TOP LIFT WITH $\frac{1}{2}$ " AGGREGATE; LOWER LIFTS WITH $\frac{3}{4}$ " AGGREGATE.
6. SLOUGHING OF TRENCH UNDER PAVEMENT SHALL BE CAUSE FOR REQUIRING ADDITIONAL PAVEMENT AND BASE. LIMITS OF WORK TO BE DETERMINED BY THE CITY ENGINEER.
7. EXISTING STRIPING AND/OR TRAFFIC SIGNAL LOOPS TO BE REPLACED WITHIN 5 WORKING DAYS.
8. IN AN EFFORT TO MAINTAIN A STREET'S EXPECTED LIFESPAN, RETURN THE STREET TO THE SAME OR SIMILAR CONDITION AS BEFORE TH TRENCHING TOOK PLACE, AND TO MEET CITY OF CHULA VISTA AND GREENBOOK STANDARDS PERTAINING TO ROAD SMOOTHNESS:
 - * IF THE TRENCH IS LOCATED WITHIN A BIKE LANE, THEN THE ENTIRE BIKE LANE WIDTH SHALL BE COLD PLANED 1-1/2" MINIMUM AND OVERLAYED 1-1/2" MINIMUM.
 - * IF THE TRENCH IS WITHIN 24" OF A CONCRETE STRUCTURE (I.E. LIP OF GUTTER, VAULT, ETC.) THEN THE AREA BETWEEN THE TRENCH AND THE CONCRETE STRUCTURE SHALL BE COLD PLANED 1-1/2" MINIMUM AND OVERLAYED 1-1/2" MINIMUM.
 - * IF THE TRENCH IS LOCATED LONGITUDINALLY WITHIN THE TRAVEL LANE OF A PRIME, MAJOR, OR 4-LANE COLLECTOR STREET, THEN THE ENTIRE LANE SHALL BE COLD-PLANE 1-1/2" MINIMUM AND OVERLAYED 1-1/2" MINIMUM. HOWEVER, THE CITY ENGINEER MAY, ON A CASE-BY-CASE BASIS AND AT HIS/HER SOLE DISCRETION, MODIFY THE REQUIREMENT TO COLD PLANE AND OVERLAY THE ENTIRE LANE BASED UPON THE FOLLOWING CRITERIA: (1) EXISTING CONDITION OF THE PAVEMENT; (2) FUTURE REHABILITATION STRATEGIES AND SCHEDULE; (3) DEPTH OF TRENCH; OTHER TRENCH WORK IN THE AREA; (5) EXISTENCE OF A COMPARABLE TRENCH PAVING TECHNOLOGY OR TECHNIQUES WHICH WOULD ACHIEVE THE DESIRED ROAD SMOOTHNESS AND LONGEVITY; AND (6) OTHER SITE-SPECIFIC CONDITIONS AND FACTORS DEEMED BY THE CITY ENGINEER TO ALLEVIATE THE NEED TO COLD-PLANE AND OVERLAY THE ENTIRE LANE.
 - * THOSE ENTITIES WISHING THE CITY ENGINEER TO CONSIDER MODIFYING THE REQUIREMENT TO COLD-PLANE AND OVERLAY THE ENTIRE LANE SHALL, PRIOR TO PERMIT ISSUANCE, SUBMIT A WRITTEN REQUEST FOR SUCH MODIFICATION. SAID WRITTEN REQUEST SHALL INCLUDE A DETAILED DESCRIPTION OF THE PROJECT, THE PROJECT AREA AND THE REASONS WHY THE FULL-LANE REQUIREMENT SHOULD BE WAIVED.
9. *IF THE STREET HAS EXISTING PAVEMENT FABRIC, THEN FABRIC OF A SIMILAR QUALITY MUST BE USED IN THE TRENCH REPAIR.

TYPE "I" ONLY (NARROW TRENCH)

10. CEMENT SLURRY BACKFILL:
 - A. CEMENT SLURRY BACKFILL SHALL HAVE A MINIMUM SLUMP OF 5-INCHES.
 - B. CEMENT SLURRY BACKFILL SHALL BE THOROUGHLY CONSOLIDATED TO ENCASE CONDUITS. TAMPERS OR VIBRATORS SHALL BE USED.
 - C. LEAN CONCRETE (TRENCH SLURRY BACKFILL) AS SPECIFIED IN SECTION 201-1.1.2 OF THE GREEN BOOK CONCRETE CLASS 100-E-100.
 - D. ALLOW CEMENT SLURRY BACKFILL 24 HOURS MINIMUM TO CURE BEFORE RESURFACING.
11. TYPE I-1 REQUIRES THE PLACEMENT OF THE PETROTAC TYPE PAVEMENT FABRIC AFTER THE PLACEMENT OF THE TACK COAT. TACK COAT MUST BE APPLIED OVER PETROTAC.
12. IN STREET WITH FABRIC REINFORCING MATERIAL INSTALLED, SLURRY BACKFILL SHALL BE BROUGHT UP TO THE EXISTING FABRIC MATERIAL.

*ITEMS, IF THEY APPLY, TO BE KNOWN AT TIME OF PERMIT.

REVISION	BY	APPROVED	DATE	CITY OF CHULA VISTA ENGINEERING & CAPITAL PROJECTS STANDARD DRAWING	 WILLIAM S. VALLE 11/21/2017 CITY ENGINEER
ORIGINAL			2/90		
REVISION	CVM	A. AGHA	1/04		
REVISION	DPH	W. VALLE	11/17		
				TRENCH BACKFILL NOTES	GS1-03

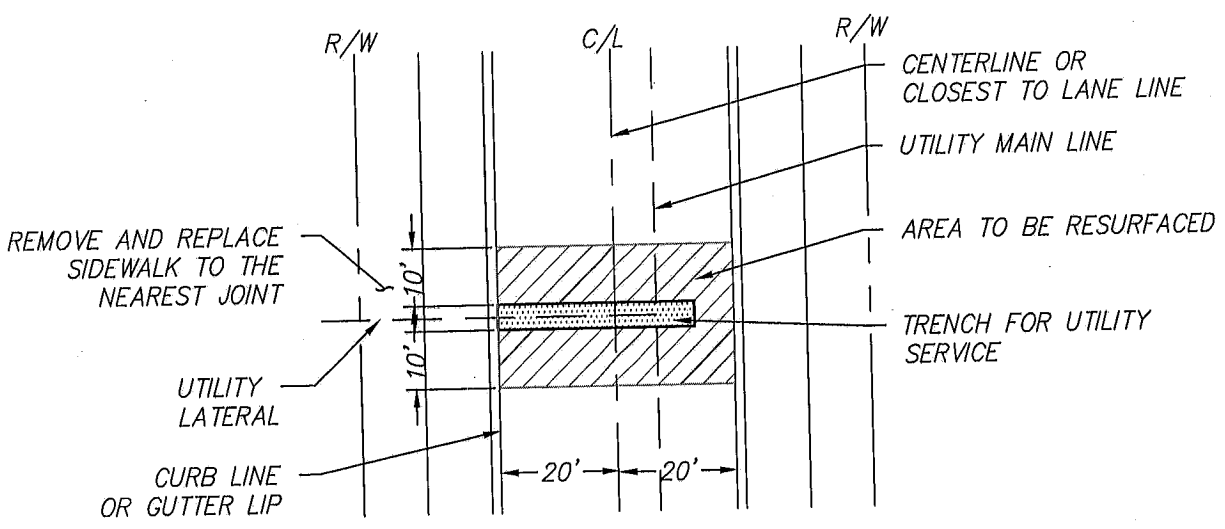
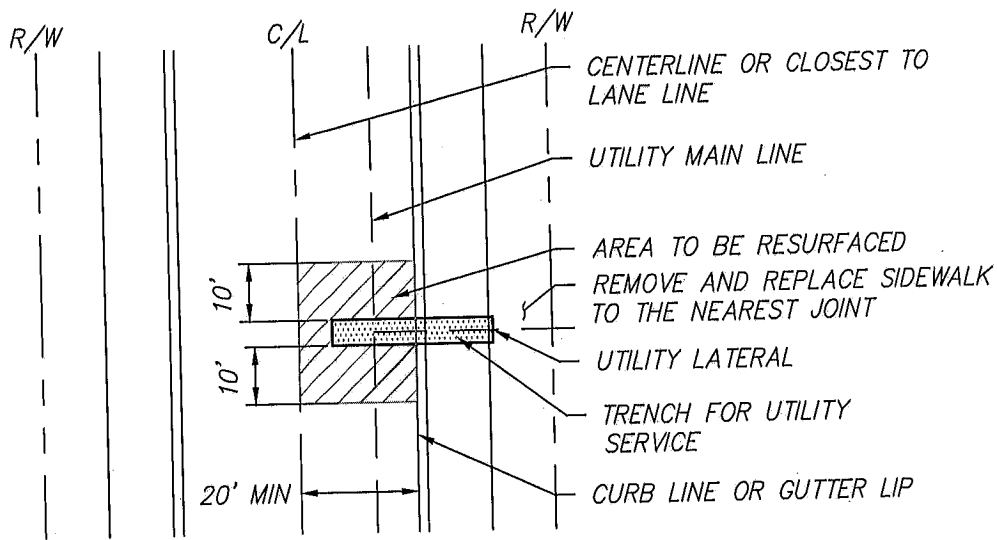

TRENCH REPAIR REQUIREMENTS FOR STREET UNDER MORATORIUM

THE FOLLOWING TRENCH REPAIR REQUIREMENTS ARE IN ADDITION TO THOSE LISTED IN CHULA VISTA CONSTRUCTION STANDARDS CVCS 3 & 4:

1. LATERAL TRENCHES (DETAILS ABOVE) - EXTEND T-CUT GRIND AND OVERLAY LIMITS TO 10 FEET BEYOND EACH SIDE OF THE TRENCH AND OVER THE ENTIRE LANE THAT IS IMPACTED (REGARDLESS OF STREET CLASSIFICATION).
2. LONGITUDINAL TRENCHES (PARALLEL TO THE CURB) - GRIND 1-1/2 INCHES MINIMUM AND PLACE 1-1/2 INCHES MINIMUM OVERLAY OVER THE ENTIRE LANE THAT IS IMPACTED (REGARDLESS OF THE CLASSIFICATION OF THE STREET).
3. REPLACE EXISTING PAVEMENT IN KIND TO MATCH EXISTING OR BETTER OR AS DIRECTED BY THE CITY ENGINEER.
4. DECORATIVE SURFACE PAVEMENT SHALL BE PROTECTED IN PLACE OR REPLACED WITH THE SAME MATERIAL WHEN DAMAGED OR AS DIRECTED BY THE CITY ENGINEER.

PER THE UTILITY TRENCH MORATORIUM POLICY NO.585-096:
 3-YEAR MORATORIUM FOR STREETS RECEIVING A SLURRY OR CHIP SEAL.
 5-YEAR MORATORIUM FOR NEWLY CONSTRUCTED, RECONSTRUCTED, AND OR OVERLAID STREETS.

REVISION	BY	APPROVED	DATE	CITY OF CHULA VISTA ENGINEERING & CAPITAL PROJECTS STANDARD DRAWING	<i>William S. Valle</i> WILLIAM S. VALLE 11/21/2017 CITY ENGINEER
ORIGINAL	DPH	W. VALLE	11/17		
				MORATORIUM ROADWAY TRENCH RESURFACING	GSI-03

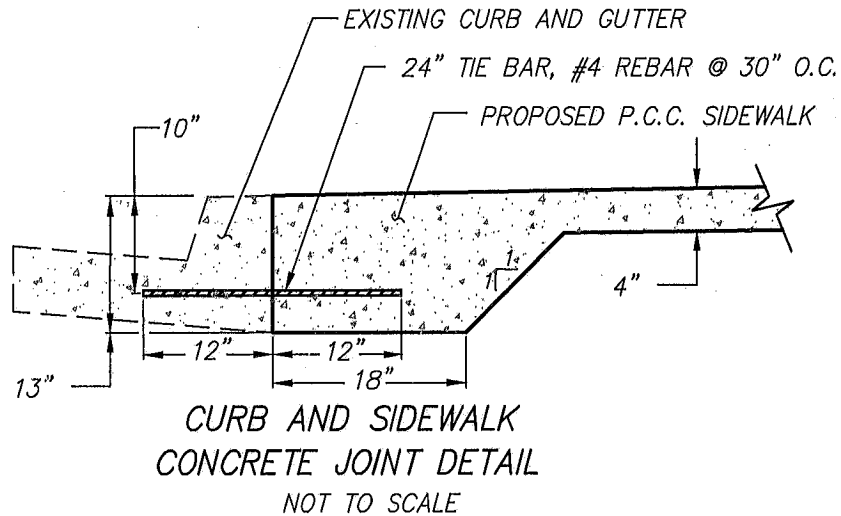
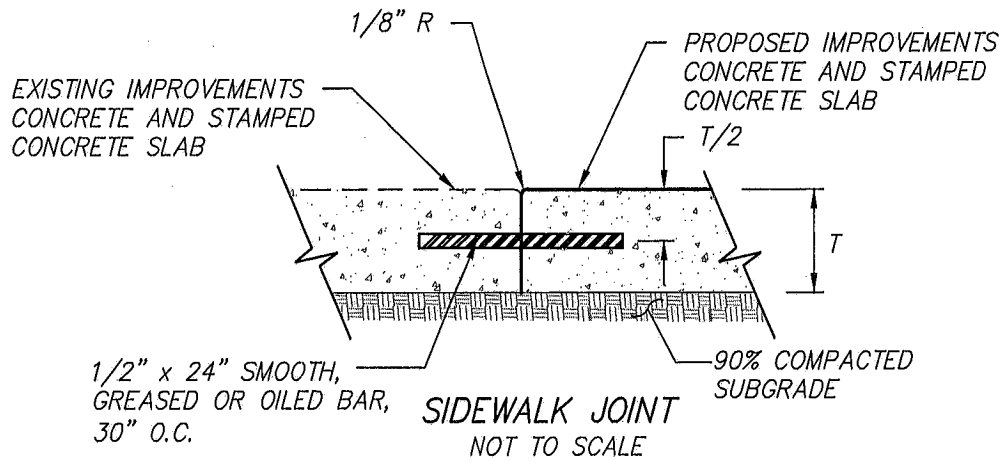
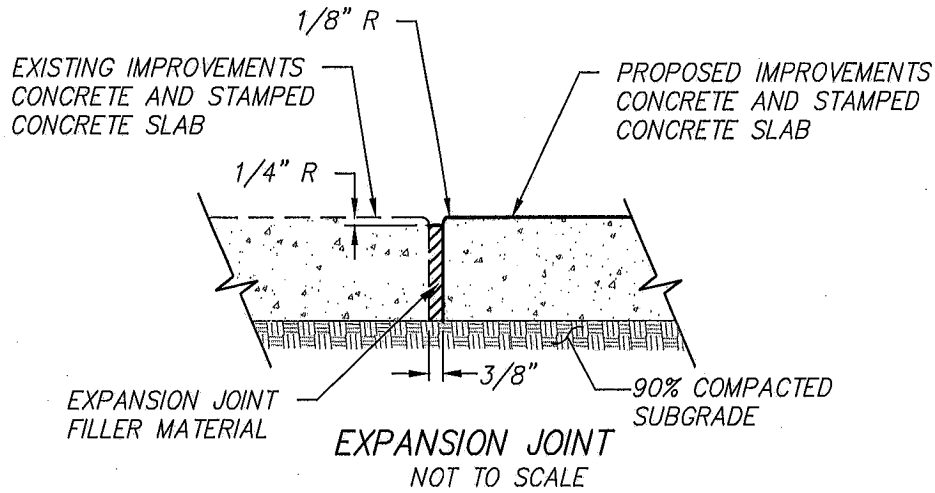

REVISION	BY	APPROVED	DATE
ORIGINAL	DPH	W. VALLE	11/17

CITY OF CHULA VISTA
ENGINEERING & CAPITAL PROJECTS
STANDARD DRAWING

CURB & SIDEWALK JOINT DETAILS

William S. Valle

WILLIAM S. VALLE 11/21/2017
CITY ENGINEER

GS1-04

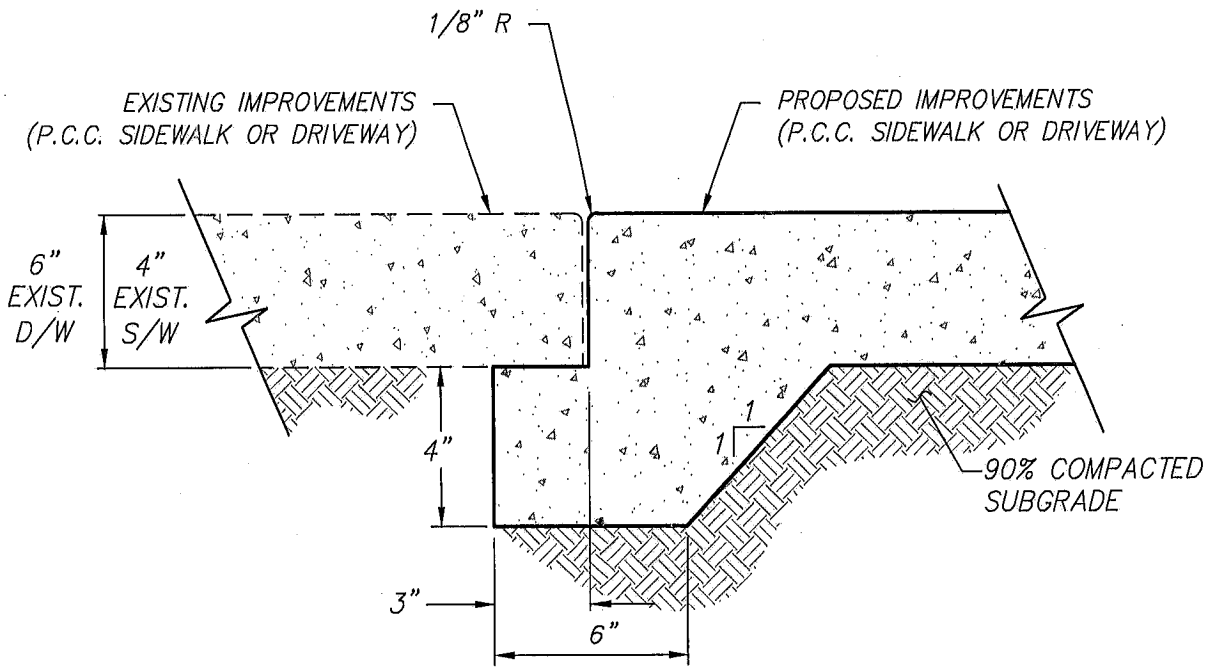

REVISION	BY	APPROVED	DATE
ORIGINAL	DPH	W. VALLE	11/17

CITY OF CHULA VISTA
ENGINEERING & CAPITAL PROJECTS
STANDARD DRAWING

SIDEWALK THICK EDGE AT DRIVEWAY

William S. Valle
WILLIAM S. VALLE 11/21/2017
CITY ENGINEER

GS1-05

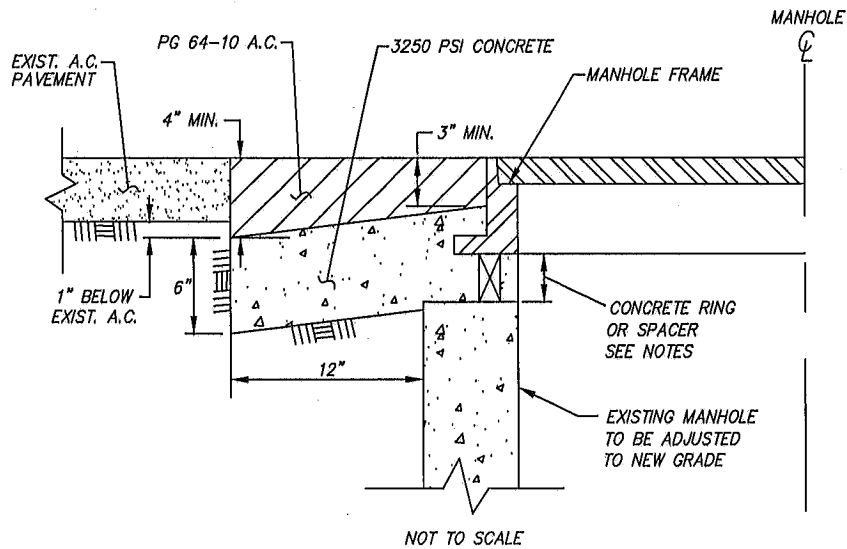

NOTES:

1. UNLESS OTHERWISE SPECIFIED, THE CONTRACTOR SHALL ADJUST ALL MANHOLE COVERS.
2. ALL COVERS SHALL BE SET 1/8" TO 1/4" HIGHER THAN THE FINISH GRADE. THE SETTING SHALL BE DONE ONLY AFTER THE ENGINEER HAS APPROVED THE PREPARED GRADE OF THE BASE MATERIAL. ALL BACKFILL SHALL BE WITH CRUSHED AGGREGATE BASE (PER SECTION 200-2.2) COMPACTED TO 95% RELATIVE DENSITY PER SECTION 211 OF THE STANDARD SPECIFICATIONS FOR FOR PUBLIC WORKS CONSTRUCTION. THE STREET SECTION SHALL BE REPLACED PER SECTION 306-1.1.5 EXCEPT A MINIMUM OF FOUR (4) INCHES OF ASPHALT CONCRETE WILL BE REQUIRED.
3. AT THE DISCRETION OF THE ENGINEER, MANHOLE COVERS MAY BE SET TO FINAL GRADE AFTER PAVEMENT HAS BEEN COMPLETED. THE SUBGRADE BASE AND PAVEMENT SHALL BE NEATLY REMOVED A DISTANCE OF TWELVE (12) INCHES FROM THE EDGE OF COVER. ALL SPOILS SHALL BE REMOVED FROM THE SITE. COVERS SHALL BE SET 1/8 OF AN INCH TO 1/4 OF AN INCH HIGHER THAN THE FINISH GRADE. ALL BACKFILL SHALL BE WITH CLASS AGGREGATE BASE.
4. ASPHALT CONCRETE SHALL BE PLACED AND COMPACTED IN TWO LAYERS: A BASE COURSE AND A SURFACE COURSE. SURFACE COURSE SHALL BE ONE (1) INCH THICK.
5. FOR ADJUSTMENT OVER 3-INCHES, USE A PRE-CAST GRADE RING.
6. FOR ADJUSTMENT 3-INCHES OR LESS, USE 3 (MIN) EVENLY SPACED CONCRETE BLOCKS OR SPACERS FOR CONCRETE TO FLOW UNDER MANHOLE FRAME. INSIDE OF MANHOLE SHALL BE FORMED TO RETAIN CONCRETE.

REVISION	BY	APPROVED	DATE	CITY OF CHULA VISTA ENGINEERING & CAPITAL PROJECTS STANDARD DRAWING	<i>William S. Valle</i> WILLIAM S. VALLE 11/21/2017 CITY ENGINEER
ORIGINAL	DPH	W. VALLE	11/17		

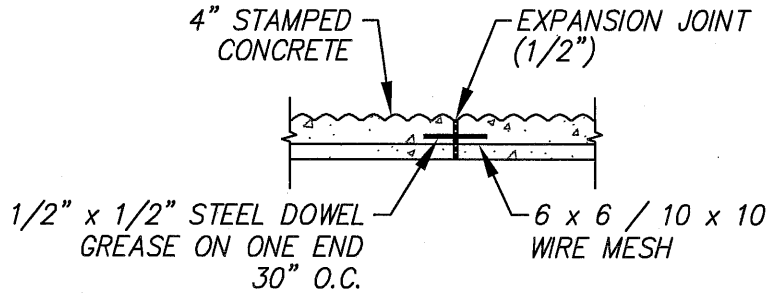

STEEL DOWEL WITH EXPANSION JOINT

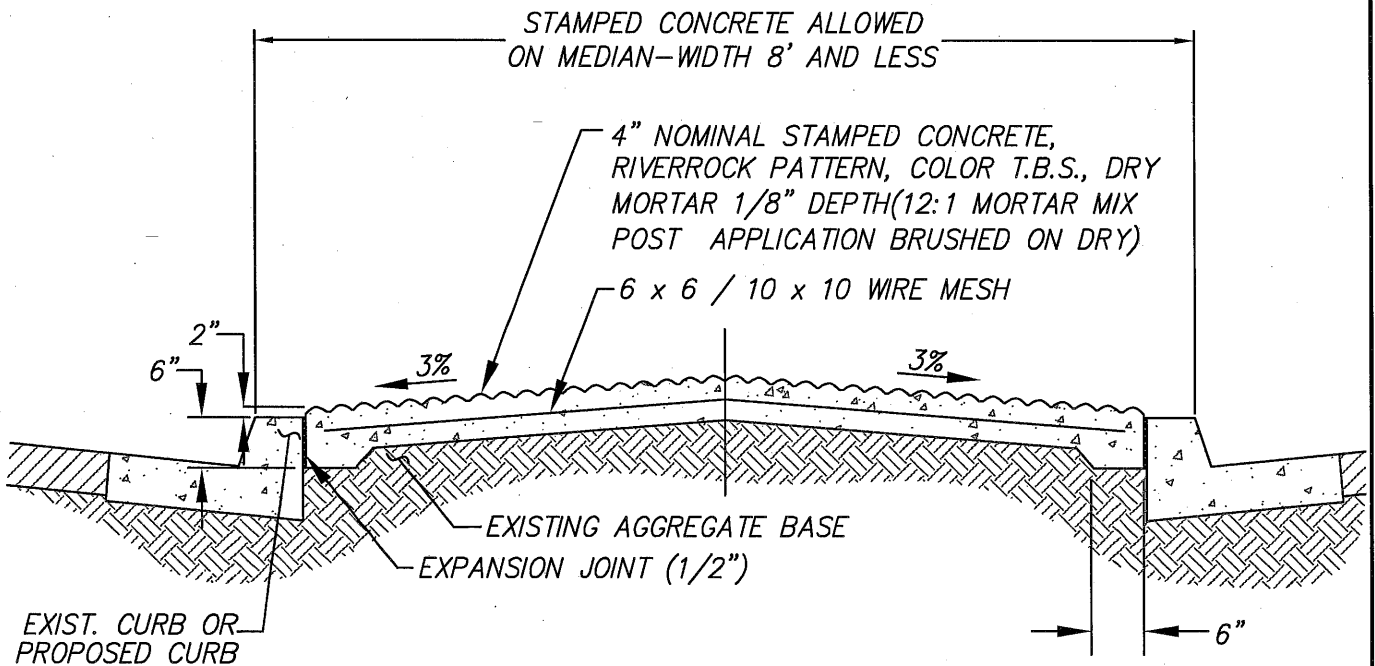

REVISION	BY	APPROVED	DATE
ORIGINAL	DPH	W. VALLE	11/17
REVISION	RAR	W. VALLE	04/19

CITY OF CHULA VISTA
ENGINEERING & CAPITAL PROJECTS
STANDARD DRAWING

STAMPED CONCRETE

William S. Valle
WILLIAM S. VALLE 04/09/2019
CITY ENGINEER

GSI-07

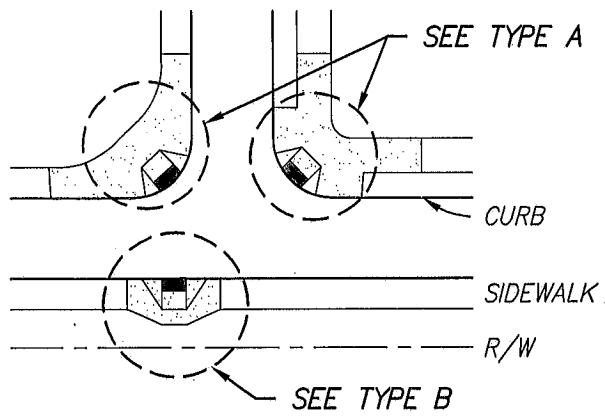

NOTES:

1. SEE DRAWING STANDARDS SSM FOR GENERAL NOTES.
2. FOR TRUNCATED DOMES DETAILS, PLEASE SEE SHEET 5
3. LANDING CROSS SLOPE AND LONGITUDINAL SLOPE SHALL BE 2% MAX.
4. Z SIDE SLOPE SHALL BE 10:1 MAX.

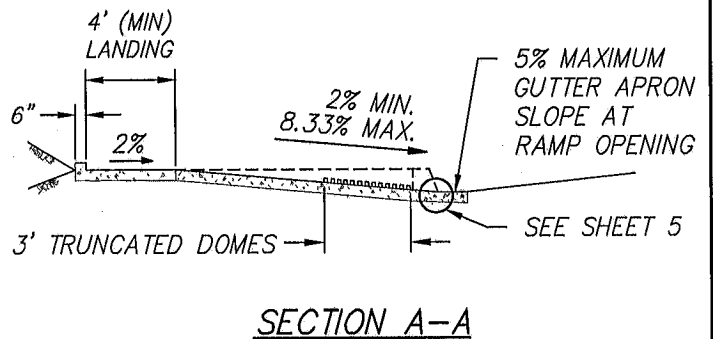
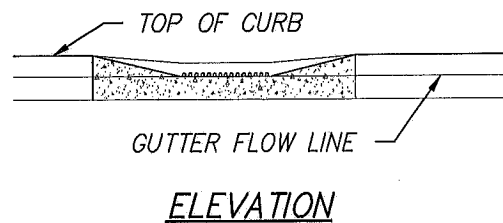
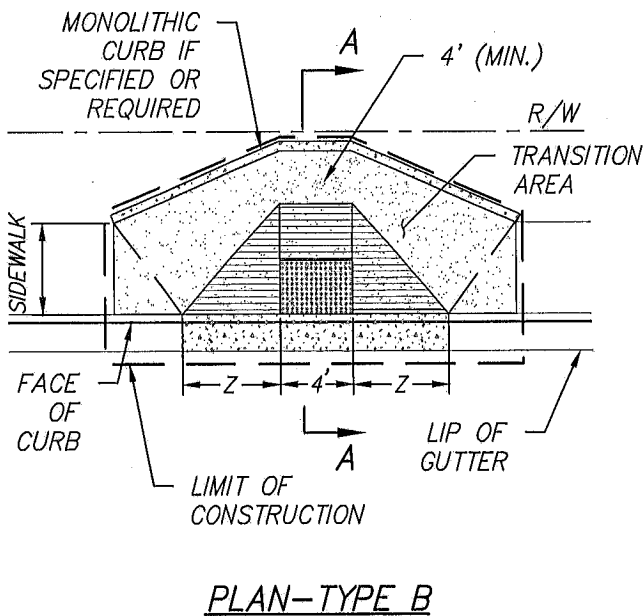
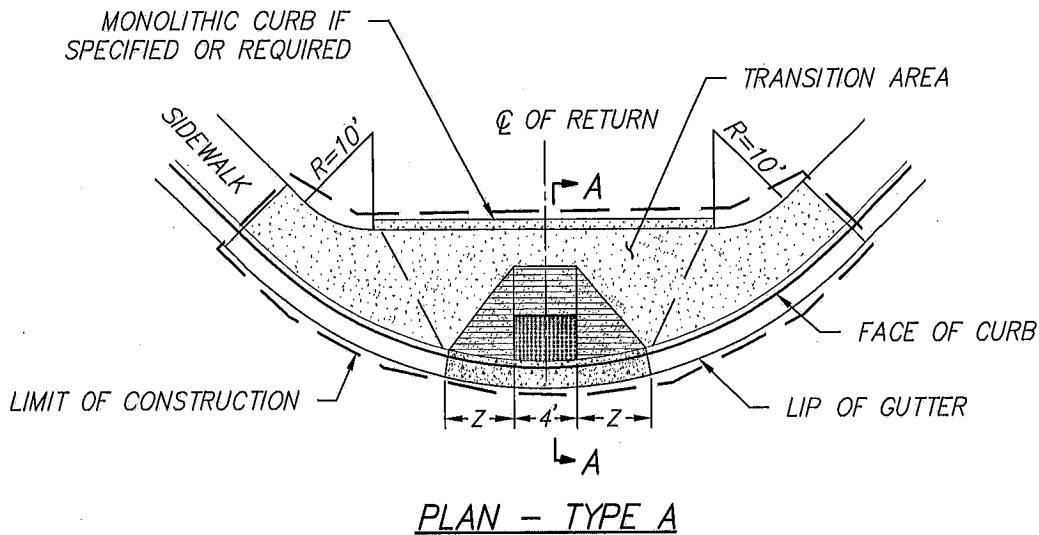

REVISION	BY	APPROVED	DATE
ORIGINAL			3/94
REVISION	CVM	C. SWANSON	11/02
REVISION	DPH	W. VALLE	11/17

CITY OF CHULA VISTA
ENGINEERING & CAPITAL PROJECTS
STANDARD DRAWING

CURB RAMP TYPES A & B - NEW
CONSTRUCTION

William S. Valle
WILLIAM S. VALLE 11/21/2017
CITY ENGINEER

GSI-08

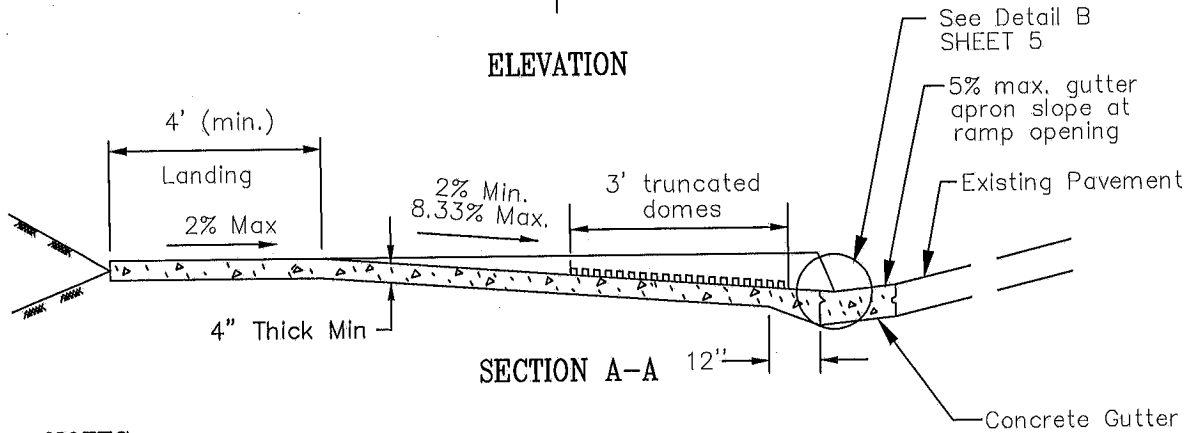
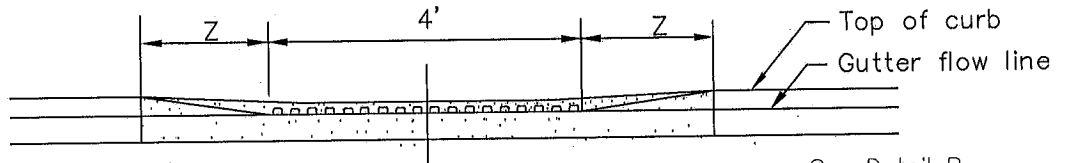
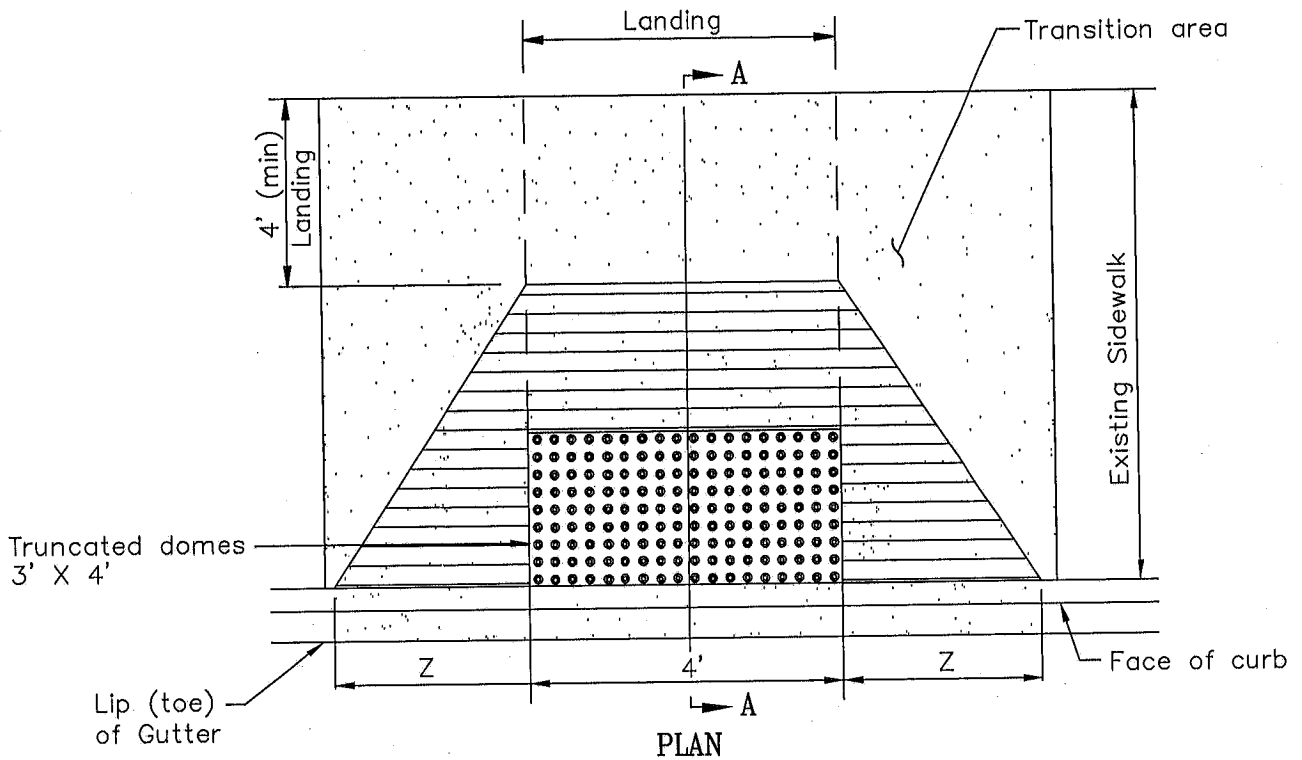

NOTES

1. See Standard Drawing CVCS-29 for general notes.
2. Type A-1 is a designation for ramp at curb return.
3. Type B-1 is a designation for ramp at straight curb (shown above).
4. Landing cross slope and longitudinal slope shall be 2% max.
5. For truncated domes details, please see sheet 5.
6. Z side slope shall be 10:1 max.

SHEET 2 OF 6

REVISION	BY	APPROVED	DATE
ORIGINAL			3/94
REVISION	CVM	C. SWANSON	11/02
REVISION	DPH	W. VALLE	11/17

CITY OF CHULA VISTA
 ENGINEERING & CAPITAL PROJECTS
 STANDARD DRAWING

CURB RAMP TYPE A1 B1 -
 EXISTING SIDEWALK

William S. Valle
 WILLIAM S. VALLE 11/21/2017
 CITY ENGINEER

GSI-08

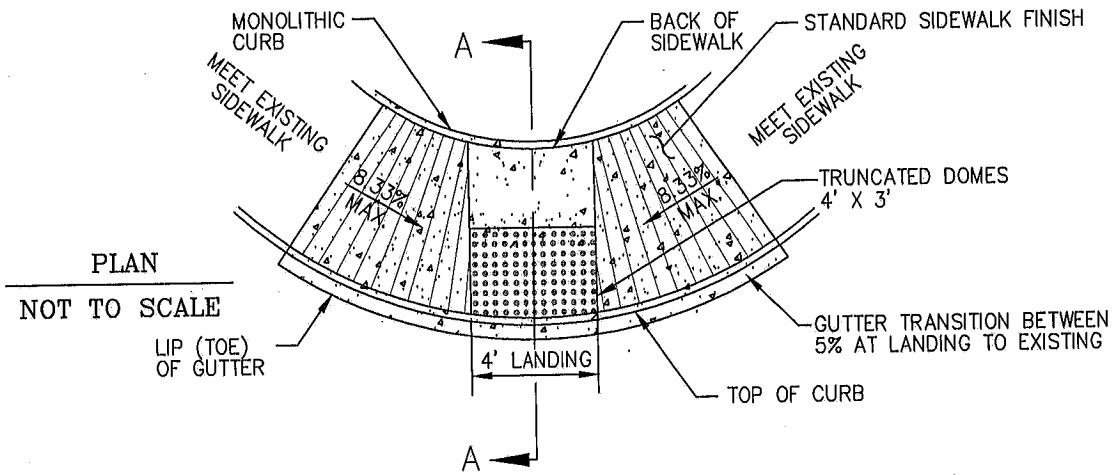

PLAN
NOT TO SCALE

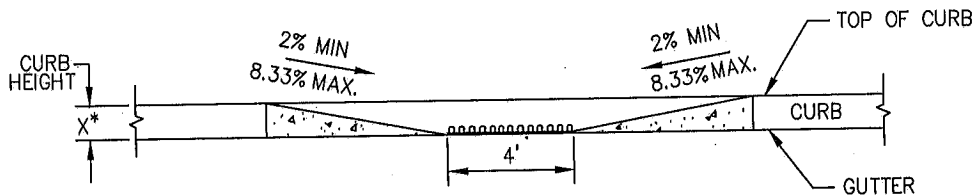

ELEVATION
NOT TO SCALE

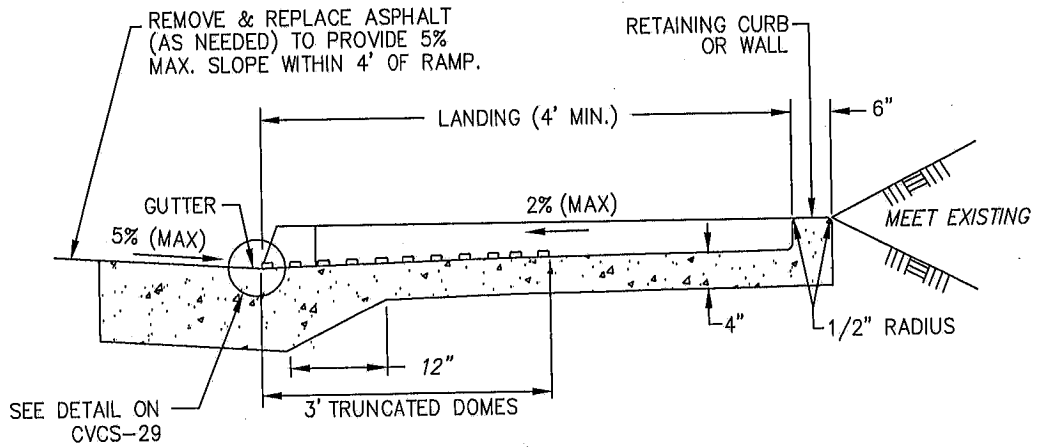

SECTION A-A
NOT TO SCALE

NOTES

1. Type C ramps are only to be used to mitigate conditions where inadequate right-of-way exists. Type C shall only be used with the approval of the City Engineer.
2. See CVCS-29 for General Notes.
3. Landing cross slope and longitudinal slope shall be 2% maximum.
4. For truncated domes, please see sheet 5
5. Sidewalk transition slope to landing shall be 8.33% maximum in all directions.

REVISION	BY	APPROVED	DATE
ORIGINAL			3/94
REVISION	CVM	C. SWANSON	11/02
REVISION	DPH	W. VALLE	11/17

CITY OF CHULA VISTA
ENGINEERING & CAPITAL PROJECTS
STANDARD DRAWING

William S. Valle
WILLIAM S. VALLE 11/21/2017
CITY ENGINEER

CURB RAMP TYPE C

GSI-08

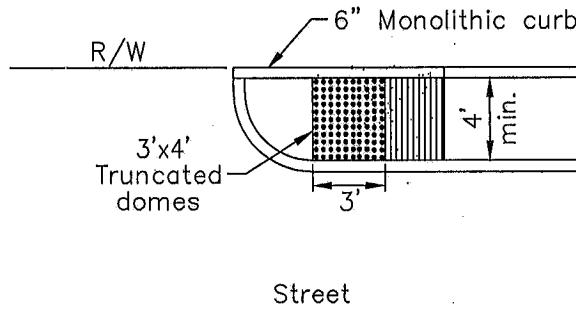
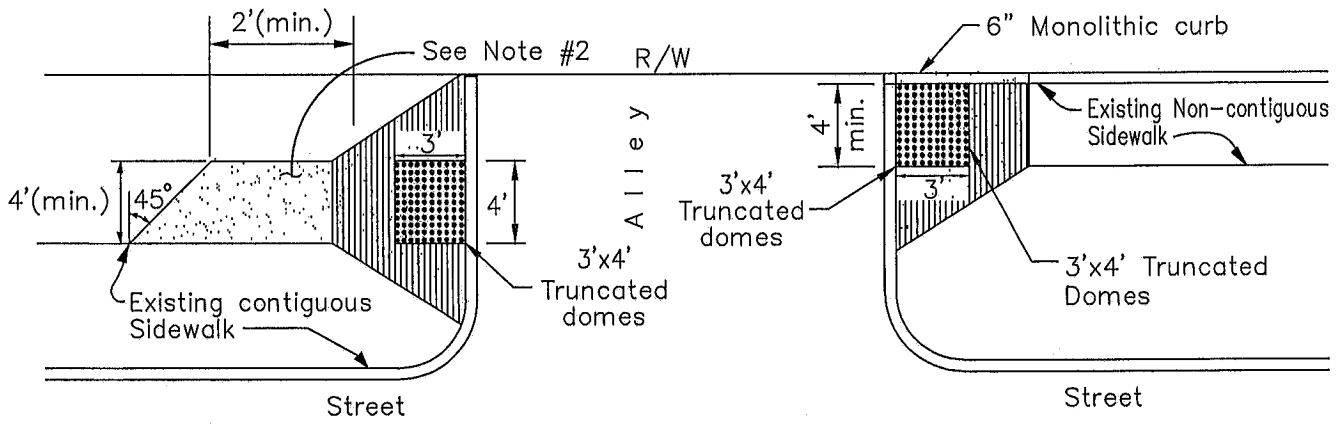

TYPICAL PLAN

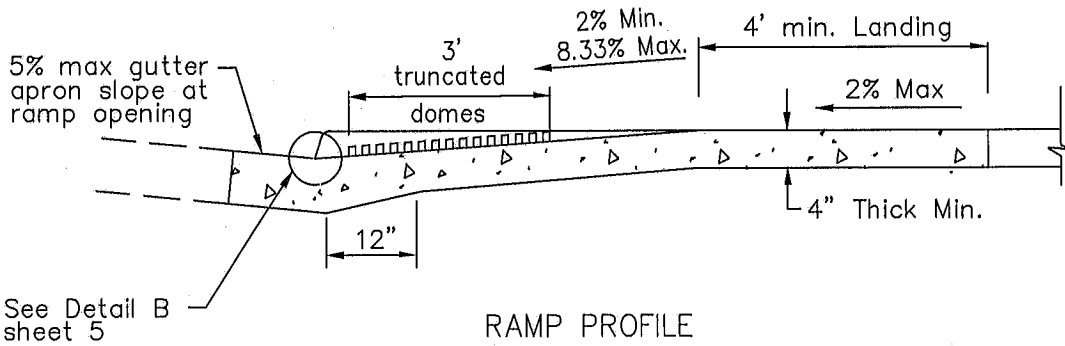

RAMP PROFILE

NOTES

1. See sheet 5 for additional details and general notes.
2. Landing cross slope and longitudinal slope shall be 2% max.
3. For truncated domes details, see sheet 6

SHEET 4 OF 6

REVISION	BY	APPROVED	DATE
ORIGINAL			3/94
REVISION	CVM	C. SWANSON	11/02
REVISION	DPH	W. VALLE	11/17

CITY OF CHULA VISTA
ENGINEERING & CAPITAL PROJECTS
STANDARD DRAWING

William S. Valle
WILLIAM S. VALLE 11/21/2017
CITY ENGINEER

CURB RAMP TYPE D

GSI-08

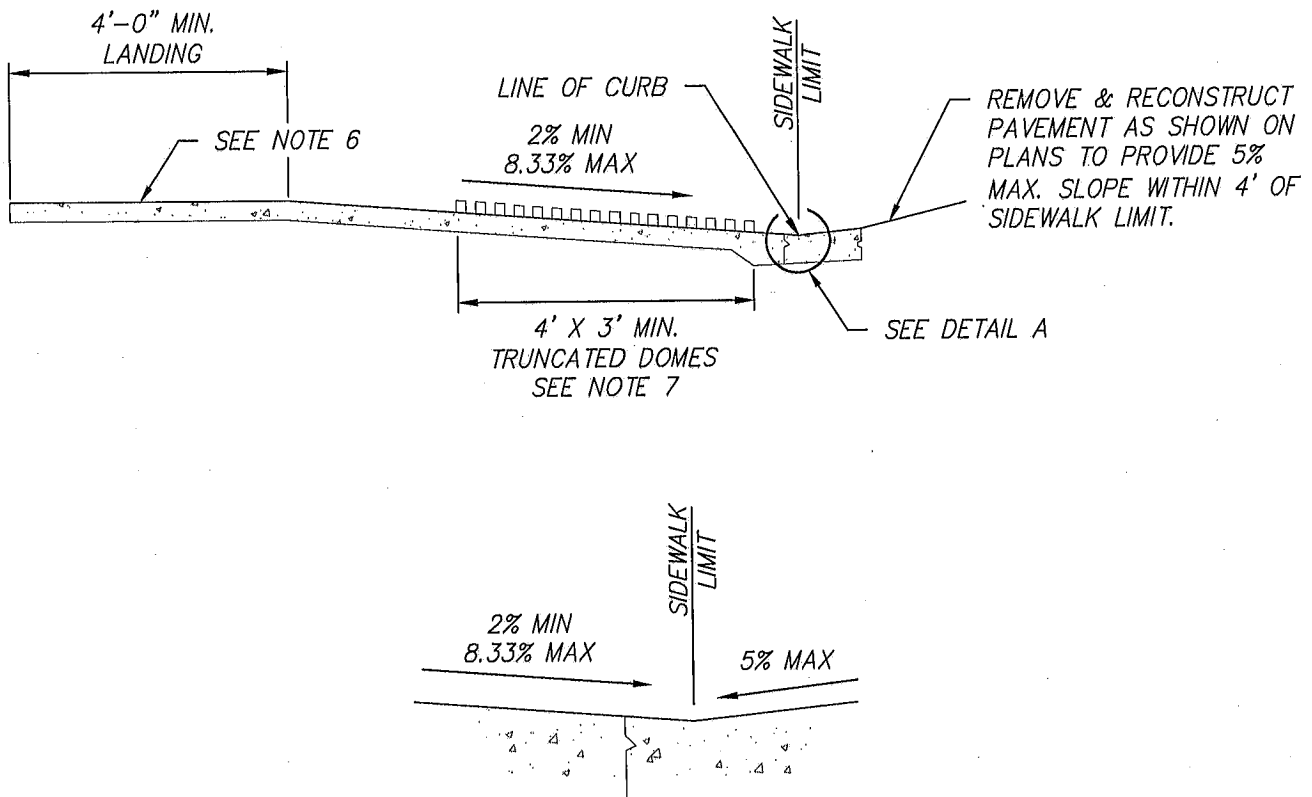

DETAIL A
NOT TO SCALE

NOTES

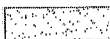
1. FOR CONSTRUCTION OF CURB RAMPS ON EXISTING SIDEWALKS, REMOVAL OF ADDITIONAL SIDEWALK MAYBE REQUIRED TO COMPLY WITH ADA REQUIREMENTS TO MEET THE EXISTING GRADE.
2. AREAS SHOWN THIS:  SHALL HAVE A MEDIUM TO HEAVY BROOM TEXTURE FINISH, PERPENDICULAR TO THE AXIS OF THE RAMP.
3. AREAS SHOWN THIS:  ARE THE MINIMUM REQUIRED FOR A COMPLETE RAMP INSTALLATION AND SHALL BE CONCRETE CLASS 520-C-2500.
4. IF OBSTRUCTIONS SUCH AS INLETS, UTILITY POLES, FIRE HYDRANTS, ETC., ARE ENCOUNTERED, THE RAMP LOCATIONS MAY BE ADJUSTED UPON THE APPROVAL OF THE RESIDENT ENGINEER OR AGENCY INSPECTOR. NO UTILITY BOX COVERS, GRATES, ETC. SHALL BE ALLOWED WITHIN THE RAMP AREA AND LANDING. 5. ADJOINING SLOPE BEYOND RAMP SHALL NOT EXCEED 20:1 (5%) WITHIN 4' OF SIDEWALK LIMIT WITH MAXIMUM OF 2% CROSS-SLOPE.
5. LANDING CROSS SLOPE AND LONGITUDINAL SLOPE SHALL BE 2% MAX EXCEPT AT MID-BLOCK CURB RAMPS.
6. ALL PROJECTS (NEW CONSTRUCTION & ALTERATION), THE LOWER END OF 48-INCH WIDTH OF THE RAMP SHALL BE FLUSH AND FREE OF ABRUPT CHANGES BETWEEN THE BOTTOM OF THE RAMP AND THE STREET PAVEMENT SURFACE.
7. THERE SHALL BE A MINIMUM OF 6-INCHES AND A MAXIMUM OF 8-INCHES SEPARATION BETWEEN THE FACE OF THE CURB AND ANY GIVEN POINT OF THE NEAREST EDGE OF THE TRUNCATED DOMES.
8. THE RAMP LONGITUDINAL SLOPE SHALL BE 2% MINIMUM AND 8.33% MAXIMUM. RAMP CROSS-SLOPE SHALL BE 2% MAXIMUM.
9. EXCEPTIONS MAY BE ALLOWED IN EXISTING CONSTRUCTION AND ALTERATIONS UPON CITY ENGINEER APPROVAL THAT FULL COMPLIANCE IS TECHNICALLY INFEASIBLE.
10. IF PEDESTRIAN PATH IS WIDER THAN 4', THE TRUNCATED DOMES WILL EXTEND THE ENTIRE WIDTH OF THE PATH.
11. DETECTABLE WARNINGS SHALL BE LOCATED SO THE EDGE NEAREST THE CURB IS 6" MIN AND 8" MAX FROM THE LINE AT THE FACE OF THE CURB MARKING THE TRANSITION BETWEEN THE CURB AND THE GUTTER, STREET OR HIGHWAY.

REVISION	BY	APPROVED	DATE	CITY OF CHULA VISTA ENGINEERING & CAPITAL PROJECTS STANDARD DRAWING	
ORIGINAL			3/94		
REVISION	CVM	C. SWANSON	11/02		
REVISION	DPH	W. VALLE	11/17		
				CURB RAMP NOTES	WILLIAM S. VALLE 11/21/2017 CITY ENGINEER
					GS1-08

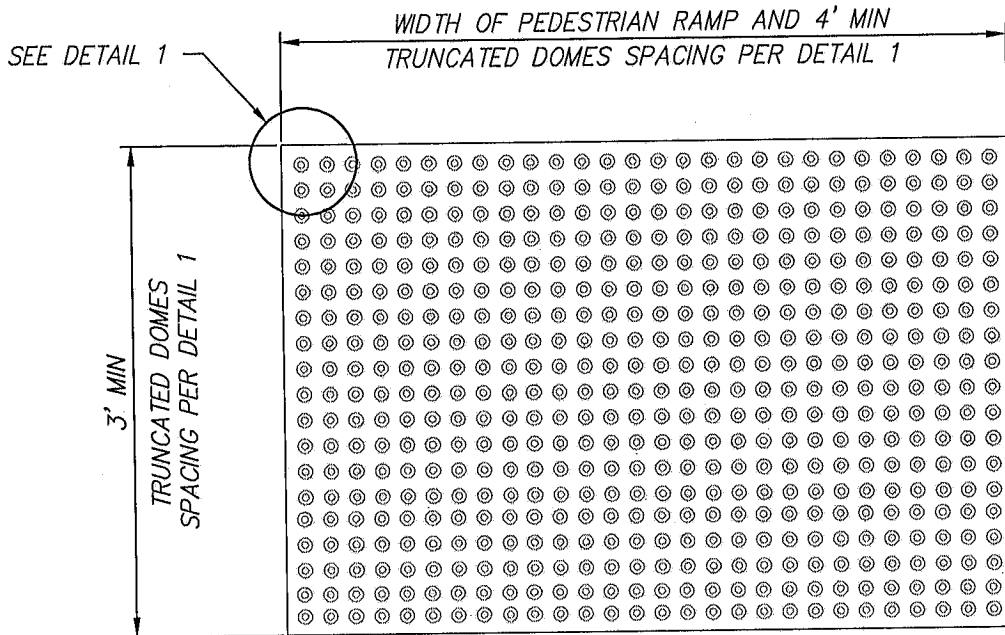

PLAN - TILE
NOT TO SCALE

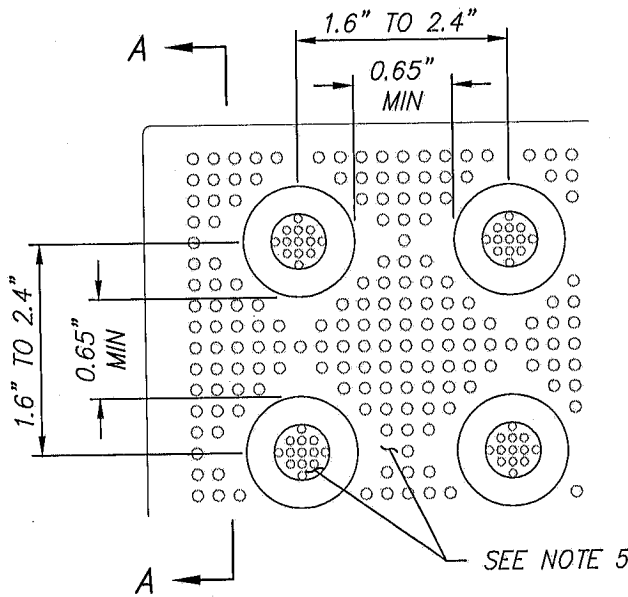

DETAIL 1
NOT TO SCALE

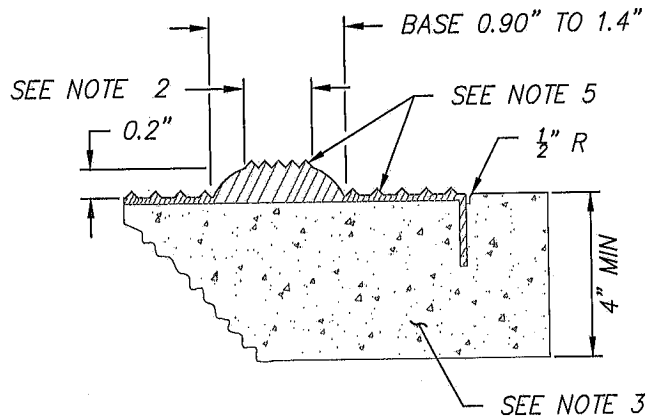

SECTION A-A
NOT TO SCALE

NOTES

1. DETECTABLE WARNING SURFACE COLOR SHALL BE YELLOW CONFORMING TO FEDERAL STANDARDS 595B TABLE IV, COLOR NO. 33538. COLOR SHALL BE HOMOGENEOUS THROUGHOUT THE TILE.
2. TRUNCATED DOME TOP DIAMETER OF 50% OF THE BASE DIAMETER MINIMUM TO 65% OF THE BASE DIAMETER MAXIMUM.
3. DURING AND AFTER THE TILE INSTALLATION AND THE CONCRETE CURING STAGE, IT IS IMPERATIVE THAT THERE IS NO WALKING, LEANING OR EXTERNAL FORCES PLACED ON THE TILE TO ROCK THE TILE, CAUSING A VOID BETWEEN THE UNDERSIDE OF TILE AND CONCRETE.
4. THE TRUNCATED DOME SHALL BE ARMOUR TILE OR AN APPROVED EQUIVALENT.
5. PATTERN, SIZE, ORIENTATION AND EMBEDMENT PER MANUFACTURER'S SPECIFICATIONS

SHEET 6 OF 6

REVISION	BY	APPROVED	DATE
ORIGINAL			3/94
REVISION	CVM	C. SWANSON	11/02
REVISION	DPH	W. VALLE	11/17

CITY OF CHULA VISTA
ENGINEERING & CAPITAL PROJECTS
STANDARD DRAWING

William S. Valle
WILLIAM S. VALLE 11/21/2017
CITY ENGINEER

TRUNCATED DOMES

GSI-08

MISCELLANEOUS

(MSC)



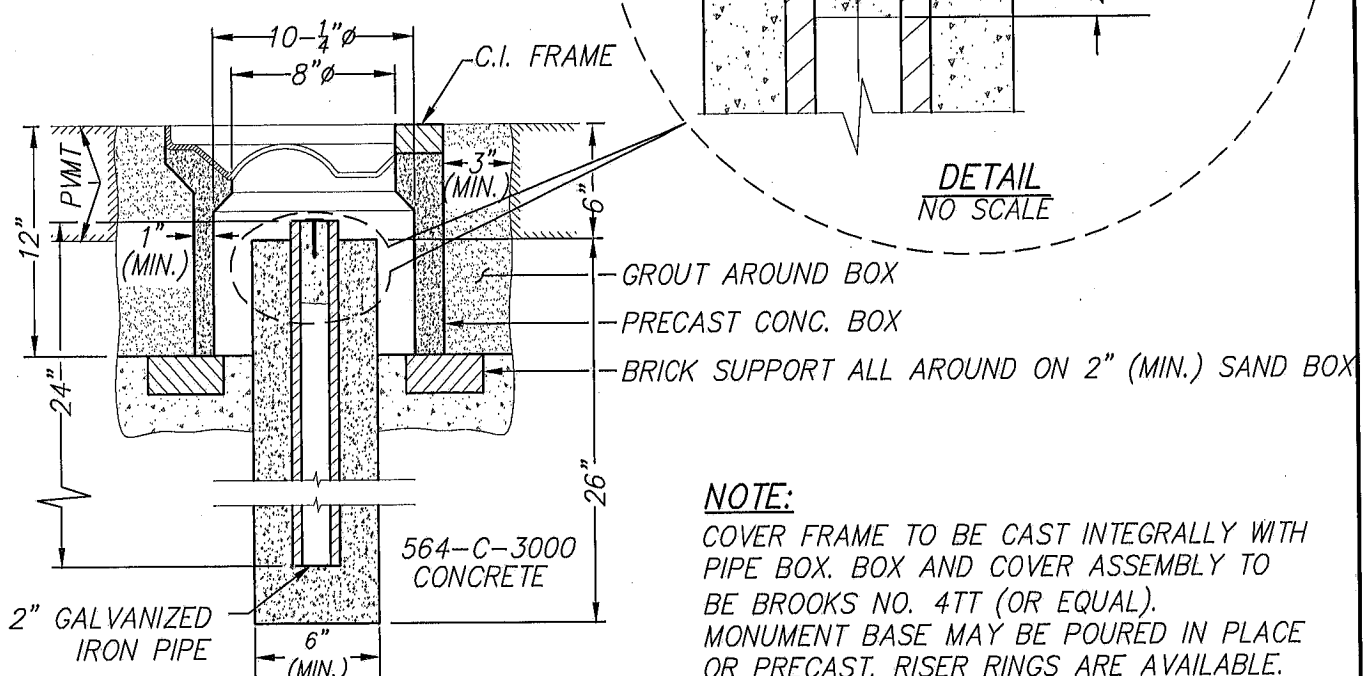
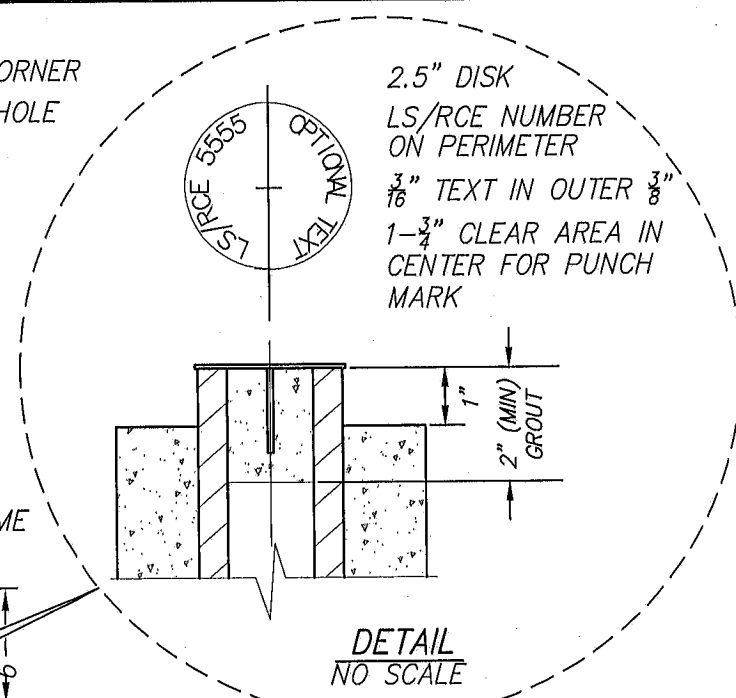
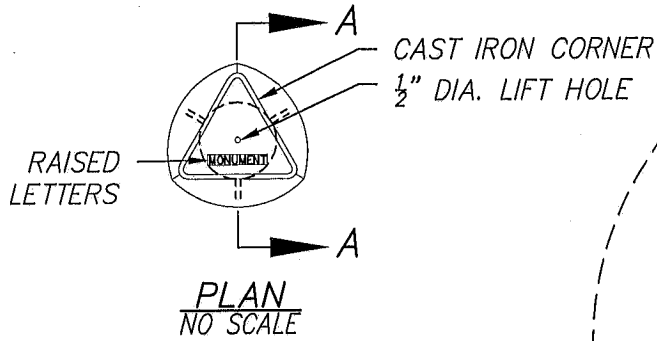

**DESIGN AND
CONSTRUCTION
STANDARD DRAWINGS
2017**

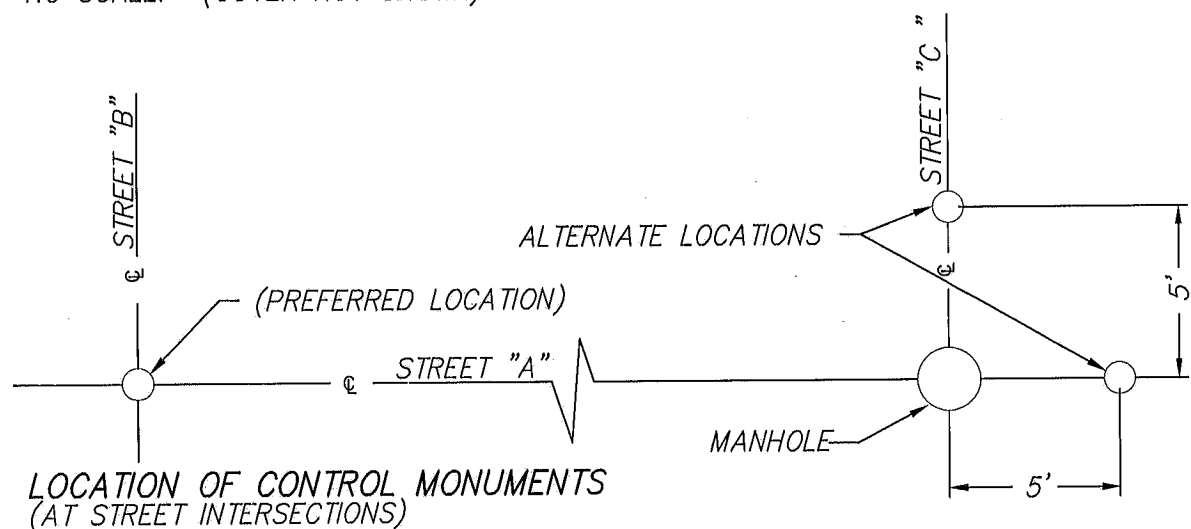

NOTE:
 COVER FRAME TO BE CAST INTEGRALLY WITH PIPE BOX. BOX AND COVER ASSEMBLY TO BE BROOKS NO. 4TT (OR EQUAL). MONUMENT BASE MAY BE POURED IN PLACE OR PRECAST. RISER RINGS ARE AVAILABLE.

SECTION VIEW "A-A"
 NO SCALE: (COVER NOT SHOWN)



REVISION	BY	APPROVED	DATE	CITY OF CHULA VISTA ENGINEERING & CAPITAL PROJECTS STANDARD DRAWING SURVEY MONUMENT (LOCATED IN STREET)	 WILLIAM S. VALLE 11/21/2017 CITY ENGINEER
ORIGINAL			7/75		
REVISION	CVM	C. SWANSON	11/02		
REVISION	DPH	W. VALLE	11/17		
					MSC-01

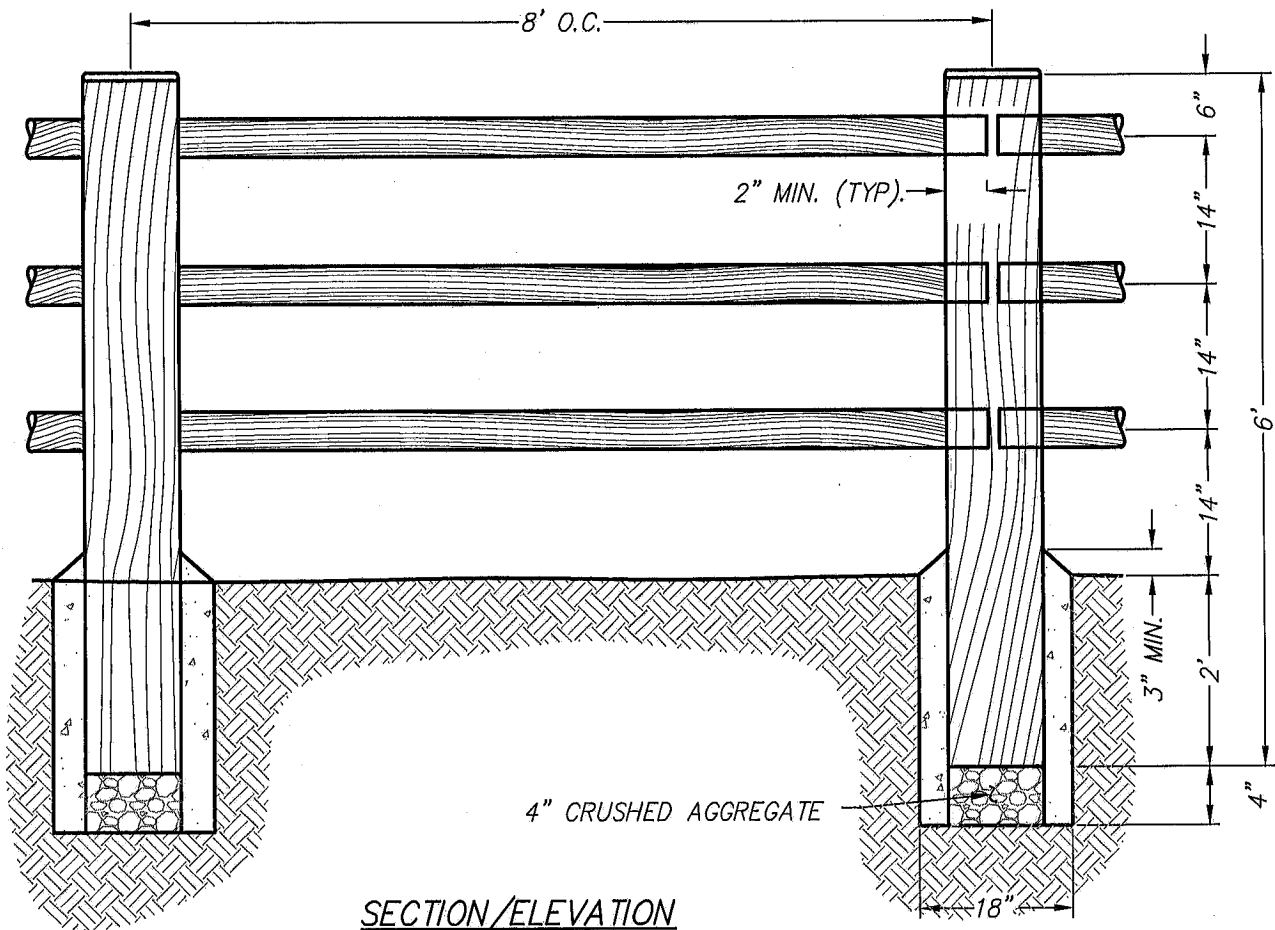

SECTION/ELEVATION
NO SCALE

NOTES:

1. POST SHALL BE 6" MIN. DIA. LODGE POLE.
2. RAILS SHALL BE 3-1/2" MIN. DIA. LODGE POLE.
3. ALL RAILS TO BE SECURED TO POST WITH 20d HOT DIPPED GALV. NAILS. 4. ALL LUMBER TO BE CCA PRESSURE TREATED.
5. SUBGRADE AT FOOTINGS TO BE 90%(MINIMUM) COMPACTION.
6. CONCRETE FOOTINGS SHALL BE 470-C-2000 "CLASS B" CONCRETE.

REVISION	BY	APPROVED	DATE	CITY OF CHULA VISTA ENGINEERING & CAPITAL PROJECTS STANDARD DRAWING	 WILLIAM S. VALLE 11/21/2017 CITY ENGINEER
ORIGINAL			12/75		
REVISION	CVM	C. SWANSON	11/02		
REVISION	DPH	W. VALLE	11/17		
				POST & RAIL FENCE	MSC-02

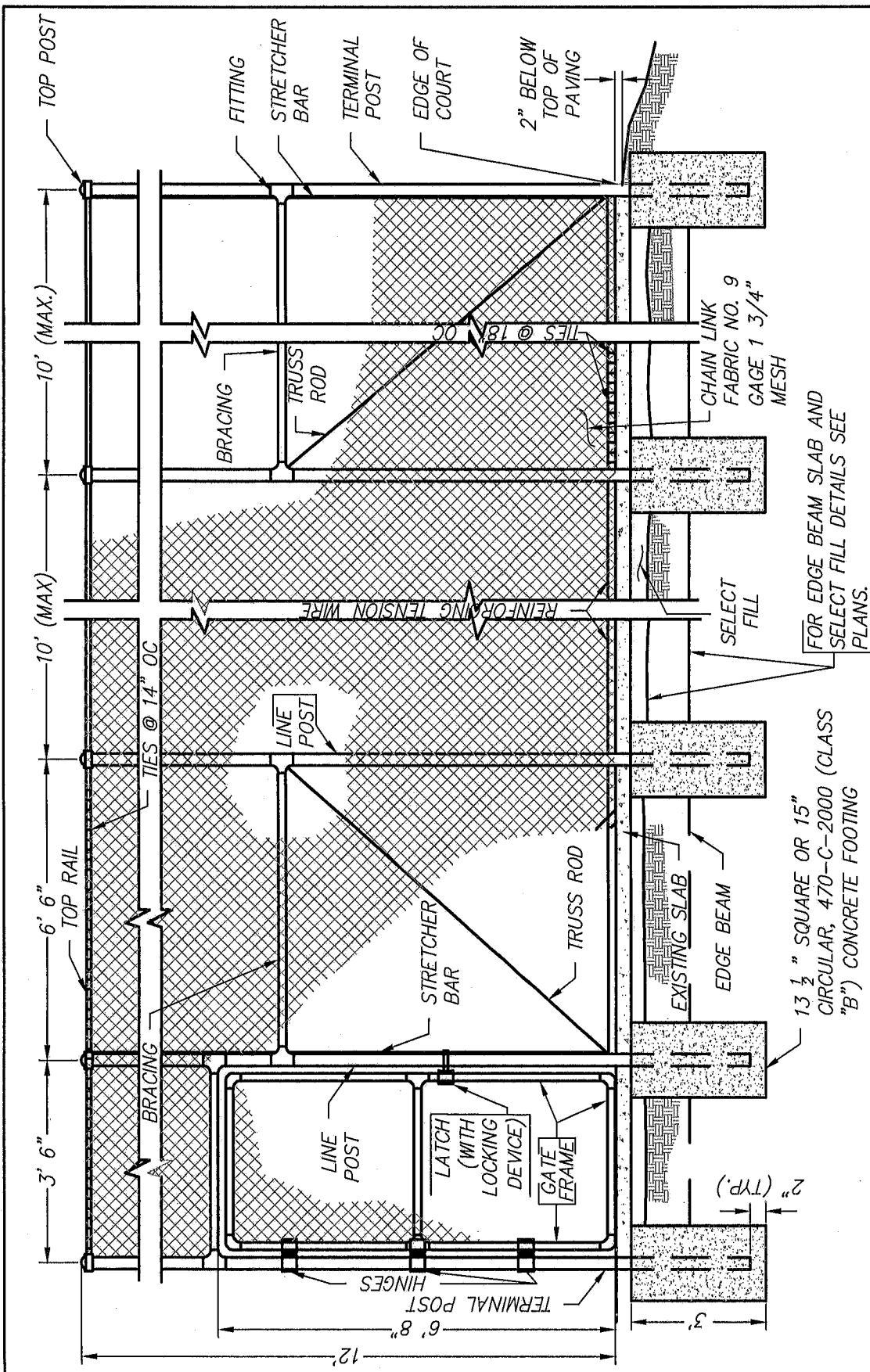

ELEVATION
NO SCALE

GENERAL NOTES:

1. MATERIAL AND CONSTRUCTION SHALL CONFORM WITH THE PROVISIONS OF SECTION 206-6.
2. CHAIN LINK FABRIC SHALL BE ERECTED ON THE INTERIOR SIDE OF COURTS.
3. GREEN MESH WIND SCREEN FABRIC FOR ENTIRE COURT TO BE PROVIDED. OF THE STD. SPECIFICATIONS, FOR PUBLIC WORKS CONSTRUCTION.

FOR EDGE BEAM SLAB AND
SELECT FILL DETAILS SEE
PLANS.

13 1/2" SQUARE OR 15"
CIRCULAR, 470-C-2000 (CLASS
"B") CONCRETE FOOTING

REVISION	BY	APPROVED	DATE
ORIGINAL			11/67
		C. SWANSON	11/02
REVISION	DPH	W. VALLE	11/17

CITY OF CHULA VISTA
ENGINEERING & CAPITAL PROJECTS
STANDARD DRAWING

CHAIN LINK TENNIS COURT FENCE

William S. Valle
WILLIAM S. VALLE 11/21/2017
CITY ENGINEER

MSC-03

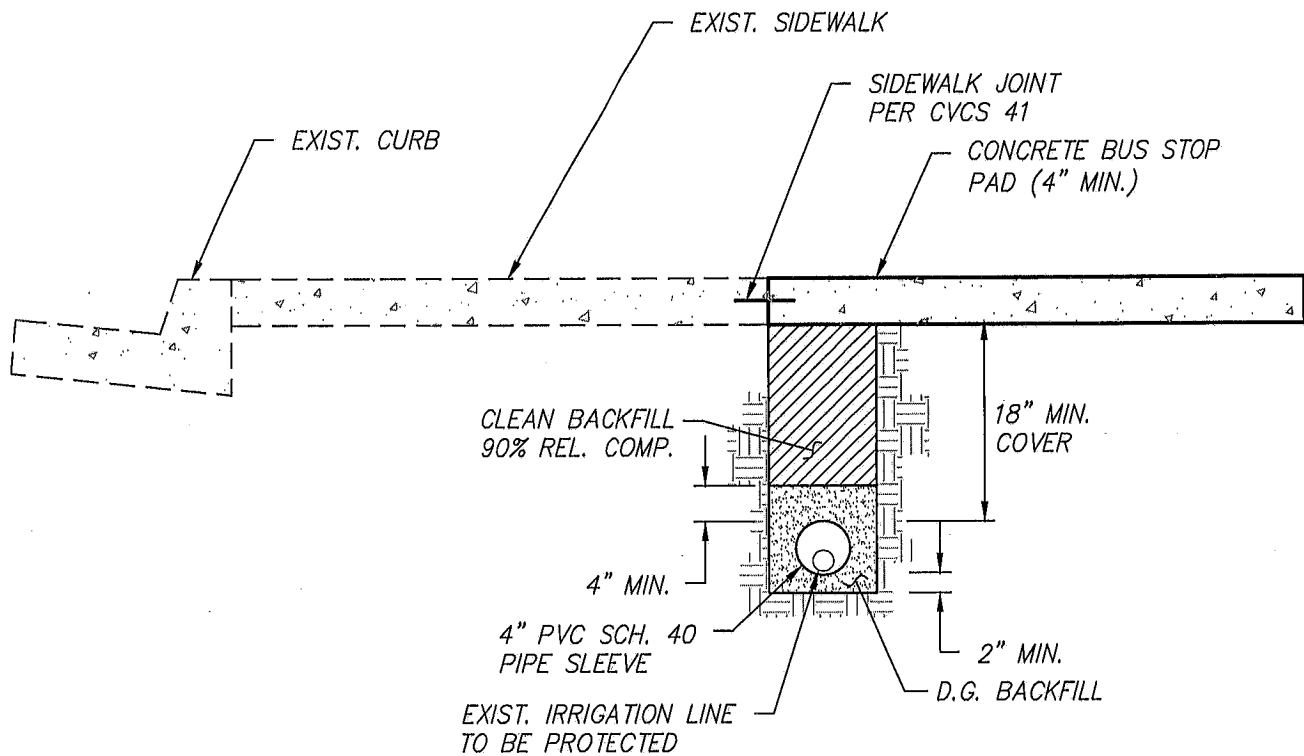

NO SCALE
(TYPICAL)

CONSTRUCTION NOTES:

1. ALL SLEEVES TO RUN A MIN. OF 12" BEYOND HARDSCAPE EDGES.
2. LOCATIONS OF ALL SLEEVES TO BE DETERMINED IN THE FIELD BY CITY INSPECTOR.
3. LOCATE ENDS (ALL) OF 4" SLEEVES WITH 3-INCH BY 3-INCH "X" SCRIBED ON SURFACE DIRECTLY ABOVE.
4. EPOXY DOWELS TO BE LOCATED 2-INCHES BELOW FINISHED SURFACE.
5. ALL SLEEVED AND RELOCATED IRRIGATION LINES / SPRAY HEADS SHALL BE IN ACCORDANCE WITH THE DIRECTION OF THE CITY INSPECTOR.

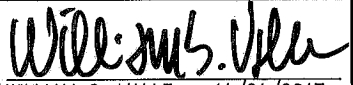
REVISION	BY	APPROVED	DATE	CITY OF CHULA VISTA ENGINEERING & CAPITAL PROJECTS STANDARD DRAWING	 WILLIAM S. VALLE 11/21/2017 CITY ENGINEER
ORIGINAL	DPH	W. VALLE	11/17		
				BUS STOP & IRRIGATION PIPE SLEEVE	MSC-04

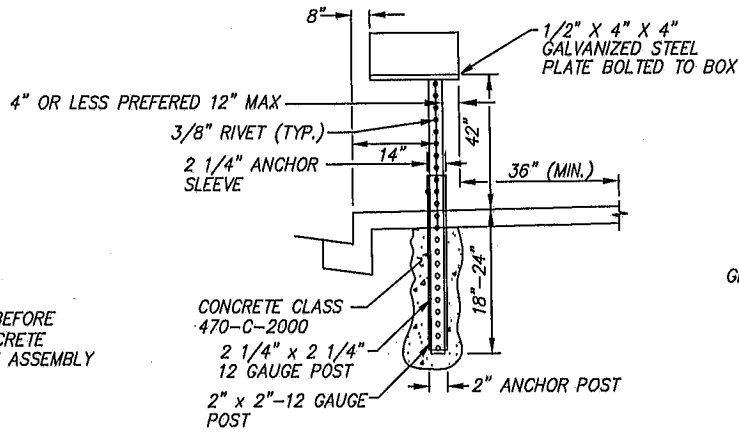

GRIP RANGE: .200-.356
 FINISH: ELECTRO-GALVANIZE
 ASTM-B-633
 TYPE III SCI

NOTE:
 TAPE HOLES BEFORE
 POURING CONCRETE
 AROUND POST ASSEMBLY

MAILBOX DETAIL (TELESPAR)
 NO SCALE

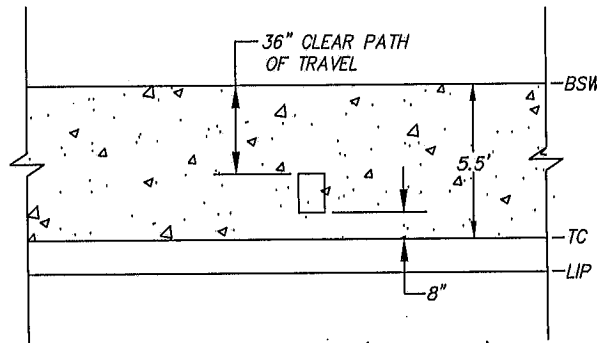

MAILBOX DETAIL (TYPICAL)
 NO SCALE

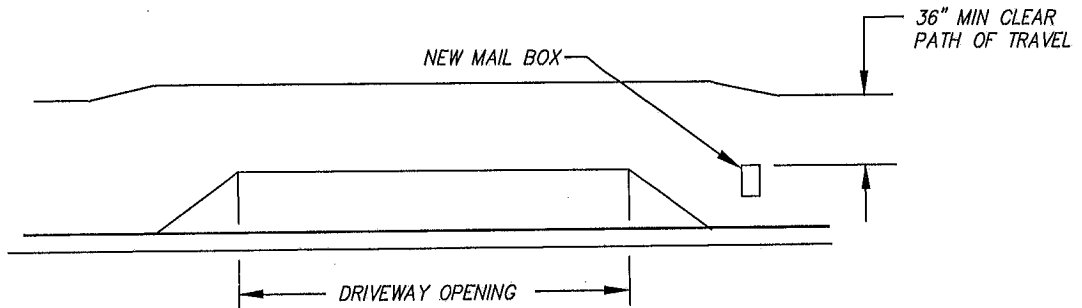

MAILBOX LOCATION WITH DRIVEWAY (TYPICAL)
 NO SCALE

REVISION	BY	APPROVED	DATE
ORIGINAL	DPH	W. VALLE	11/17

CITY OF CHULA VISTA
 ENGINEERING & CAPITAL PROJECTS
 STANDARD DRAWING

MAILBOX INSTALLATION

William S. Valle
 WILLIAM S. VALLE 11/21/2017
 CITY ENGINEER

MSC-05

ROADWAY

(RWY)



**DESIGN AND
CONSTRUCTION
STANDARD DRAWINGS
2017**

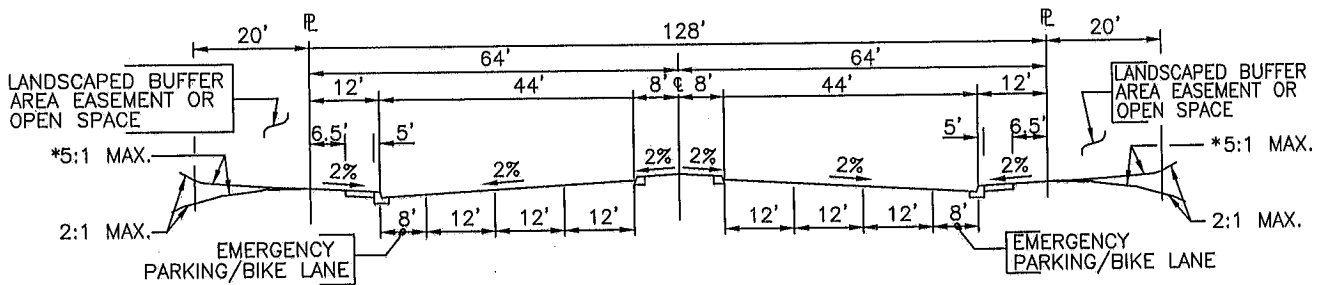

6-LANE PRIME W/ CONTIGUOUS SIDEWALK

NO SCALE

* LANDSCAPED SLOPES GREATER THAN 5:1 MAY BE ACCEPTABLE AS DETERMINED BY THE DIRECTOR OF PLANNING.

NOTES:

1. REFER TO CITY OF CHULA VISTA "STREET DESIGN STANDARDS POLICY" ADOPTED BY COUNCIL RESOLUTION #15349 ON OCTOBER 17, 1989.
2. STANDARDS MAY VARY IN DEVELOPED AREAS WEST OF I-805. REFER TO "STREET DESIGN STANDARDS POLICY".

SHEET 1 OF 4

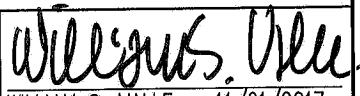
REVISION	BY	APPROVED	DATE	CITY OF CHULA VISTA ENGINEERING & CAPITAL PROJECTS STANDARD DRAWING	 WILLIAM S. VALLE CITY ENGINEER
ORIGINAL			2/90		
REVISION	CVM	C. SWANSON	11/02		
REVISION	DPH	W. VALLE	11/17		
				6-LANE PRIME STREET SECTION WITH CONTIGUOUS SIDEWALK	RWY-01

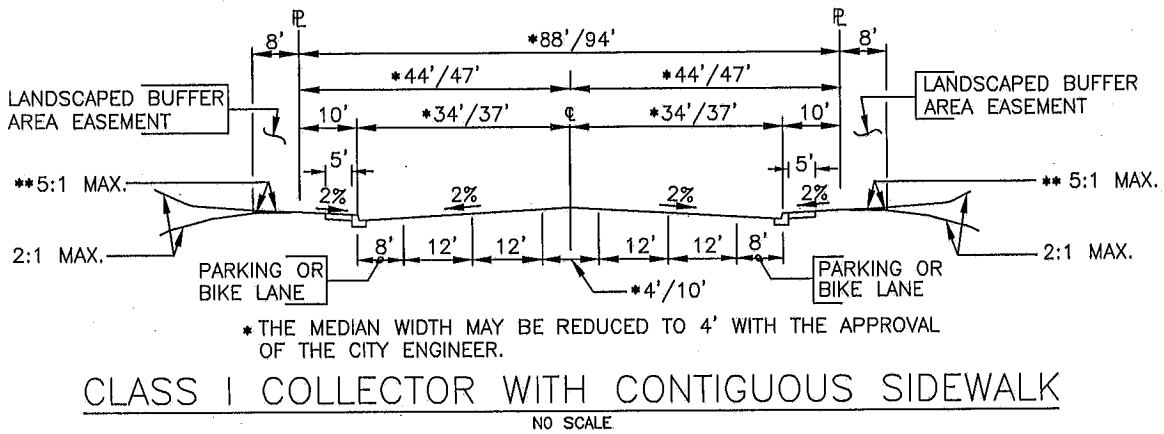
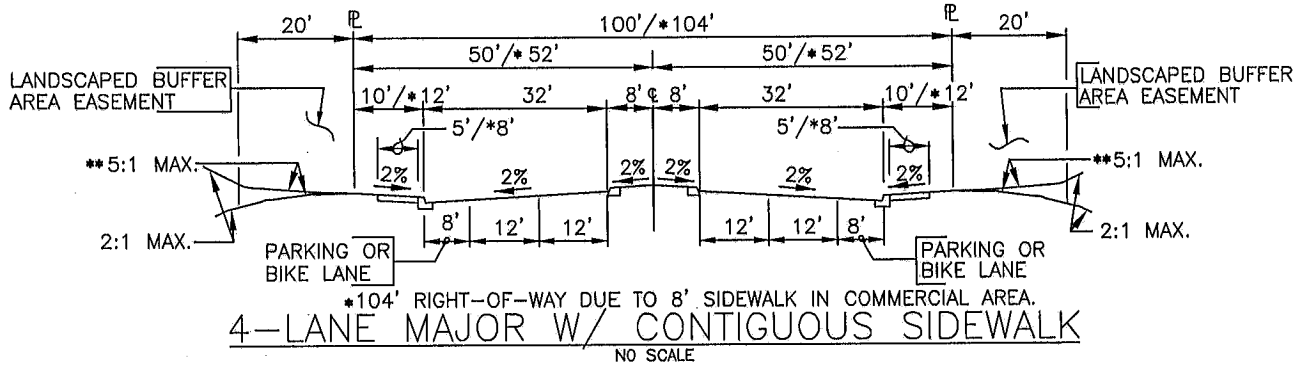

** LANDSCAPED SLOPES GREATER THAN 5:1 MAY BE ACCEPTABLE AS DETERMINED BY THE DIRECTOR OF PLANNING.

NOTES:

1. REFER TO CITY OF CHULA VISTA "STREET DESIGN STANDARDS POLICY" ADOPTED BY COUNCIL RESOLUTION #15349 ON OCTOBER 17, 1989.
2. STANDARDS MAY VARY IN DEVELOPED AREAS WEST OF I-805. REFER TO "STREET DESIGN STANDARDS POLICY".

REVISION	BY	APPROVED	DATE	CITY OF CHULA VISTA ENGINEERING & CAPITAL PROJECTS STANDARD DRAWING	<i>William S. Valle</i> WILLIAM S. VALLE 11/21/2017 CITY ENGINEER
ORIGINAL			2/90		
REVISION	CM	C. SWANSON	11/02		
REVISION	DPH	W. VALLE	11/17		
				4-LANE MAJOR AND COLLECTOR STREET WITH CONTIGUOUS SIDEWALK	RWY-01

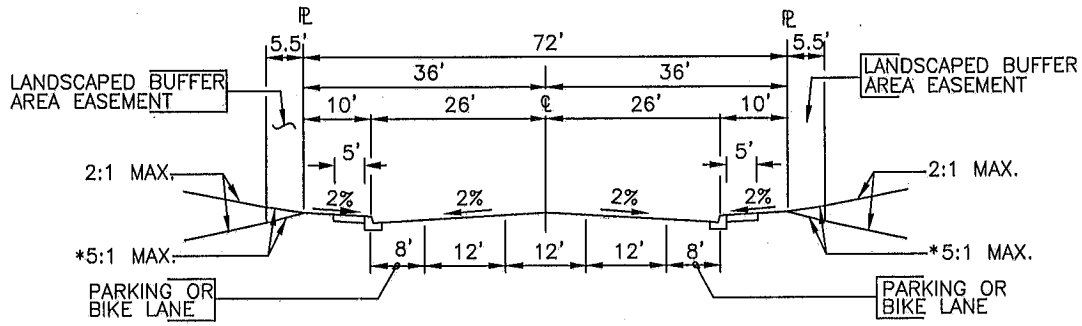

CLASS II COLLECTOR W/ CONTIGUOUS SIDEWALK

NO SCALE

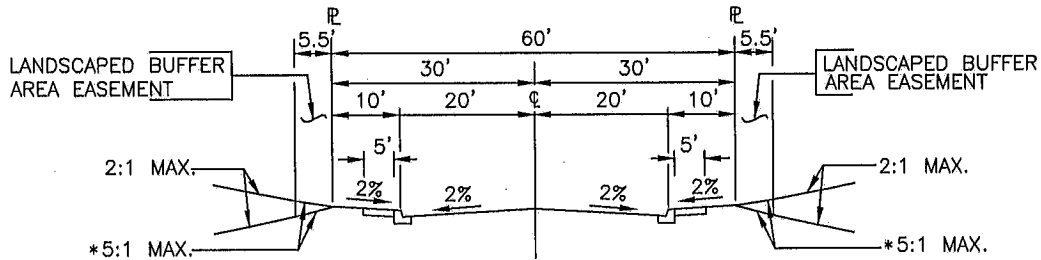

CLASS III COLLECTOR W/ CONTIGUOUS SIDEWALK

NO SCALE

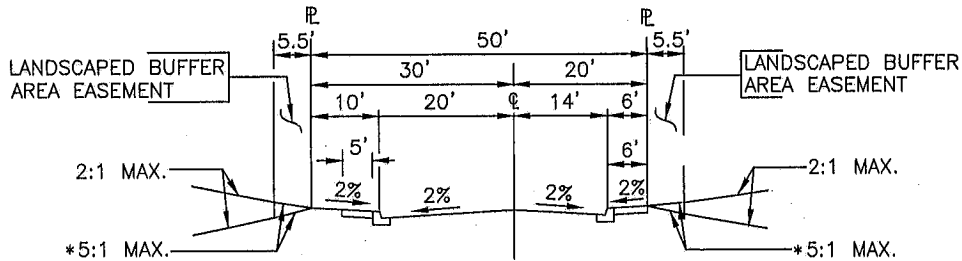

SINGLE LOADED RESIDENTIAL W/ CONTIGUOUS SIDEWALK

NO SCALE

* LANDSCAPED SLOPES GREATER THAN 5:1 MAY BE ACCEPTABLE AS DETERMINED BY THE DIRECTOR OF PLANNING.

NOTES:

1. REFER TO CITY OF CHULA VISTA "STREET DESIGN STANDARDS POLICY" ADOPTED BY COUNCIL RESOLUTION #15349 ON OCTOBER 17, 1989.
2. STANDARDS MAY VARY IN DEVELOPED AREAS WEST OF I-805. REFER TO "STREET DESIGN STANDARDS POLICY".

SHEET 3 OF 4

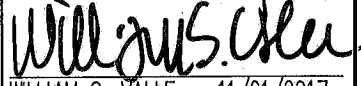
REVISION	BY	APPROVED	DATE	CITY OF CHULA VISTA ENGINEERING & CAPITAL PROJECTS STANDARD DRAWING	 WILLIAM S. VALLE CITY ENGINEER
ORIGINAL			2/90		
REVISION	CVM	C. SWANSON	11/02		
REVISION	DPH	W. VALLE	11/17		
				2-LANE COLLECTOR & RESIDENTIAL STREET WITH CONTIGUOUS SIDEWALK	RWY-01

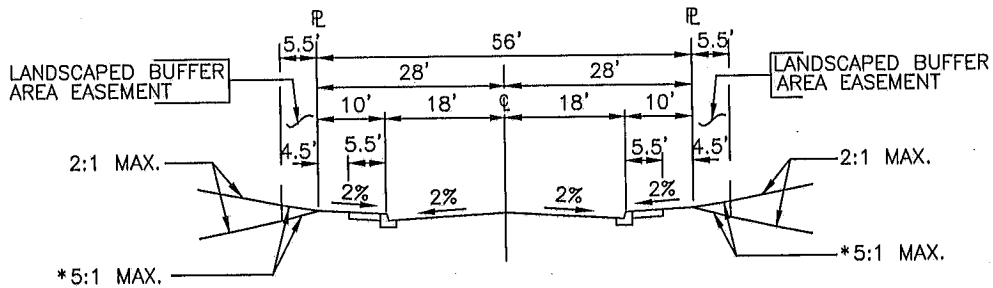

RESIDENTIAL STREET W/ CONTIGUOUS SIDEWALK

NO SCALE

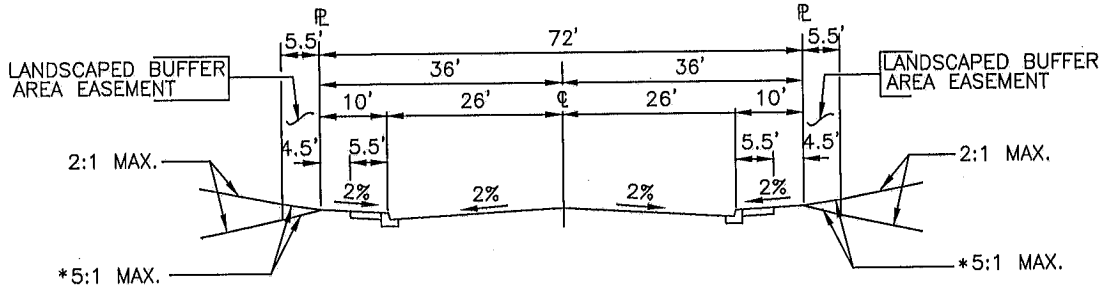

INDUSTRIAL STREET W/ CONTIGUOUS SIDEWALK

NO SCALE

* LANDSCAPED SLOPES GREATER THAN 5:1 MAY BE ACCEPTABLE AS DETERMINED BY THE DIRECTOR OF PLANNING.

NOTES:

1. REFER TO CITY OF CHULA VISTA "STREET DESIGN STANDARDS POLICY" ADOPTED BY COUNCIL RESOLUTION #15349 ON OCTOBER 17, 1989.
2. STANDARDS MAY VARY IN DEVELOPED AREAS WEST OF I-805. REFER TO "STREET DESIGN STANDARDS POLICY".

SHEET 4 OF 4

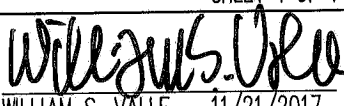
REVISION	BY	APPROVED	DATE	CITY OF CHULA VISTA ENGINEERING & CAPITAL PROJECTS STANDARD DRAWING	 WILLIAM S. VALLE CITY ENGINEER
ORIGINAL			2/90		
REVISION	CM	C. SWANSON	11/02		
REVISION	DPH	W. VALLE	11/17		
				2-LANE RESIDENTIAL & INDUSTRIAL STREET WITH CONTIGUOUS SIDEWALK	RWY-01

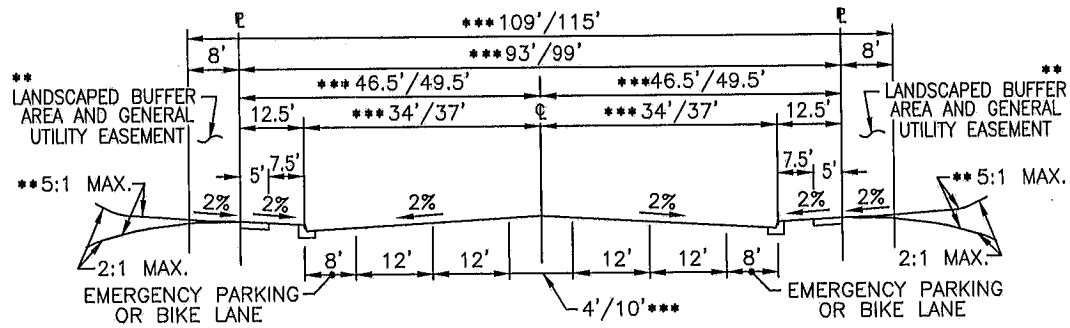
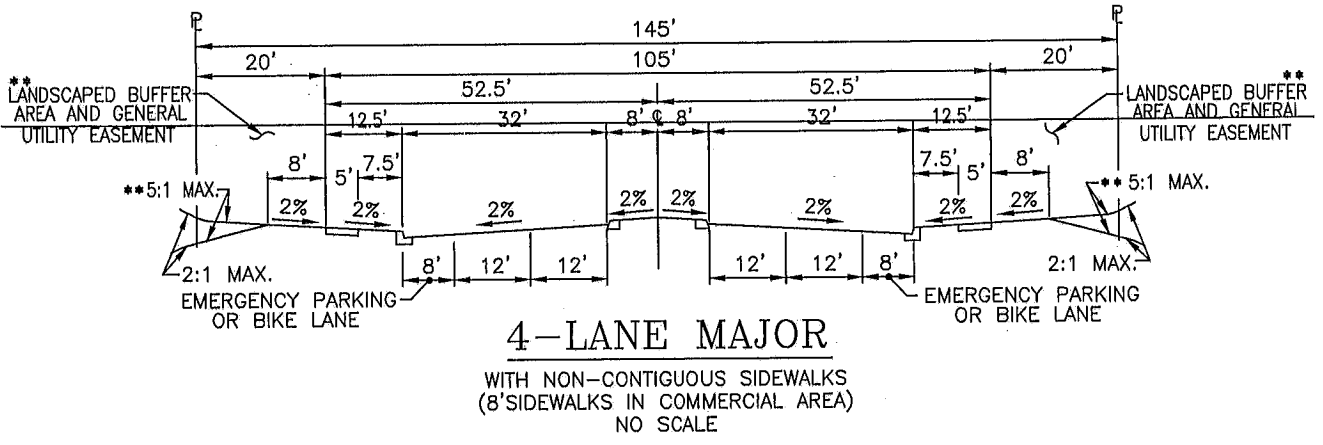

*** THE MEDIAN WIDTH MAY BE REDUCED TO 4' WITH THE APPROVAL OF THE CITY ENGINEER.

- * LANDSCAPED SLOPES GREATER THAN 5:1 MAY BE ACCEPTABLE AS DETERMINED BY THE DIRECTOR OF PLANNING.
- ** THE FIRST 5 FEET OF GENERAL UTILITY EASEMENT ADJACENT TO THE WALK SHALL BE SLOPED AT 2% GRADE.

NOTES:

1. REFER TO CITY OF CHULA VISTA "STREET DESIGN STANDARDS POLICY" ADOPTED BY COUNCIL RESOLUTION #15349 ON OCTOBER 17, 1989.
2. STANDARDS MAY VARY IN DEVELOPED AREAS WEST OF I-805. REFER TO "STREET DESIGN STANDARDS POLICY".
3. STANDARD CROSS-SECTIONS HAVE BEEN REVISED FOR NON-CONTIGUOUS SIDEWALKS.
4. TREES WITHIN 7.5' OR LESS OF HARDSCAPE SHALL HAVE ROOT BARRIERS AND DEEP WATER IRRIGATION.

REVISION	BY	APPROVED	DATE	CITY OF CHULA VISTA ENGINEERING & CAPITAL PROJECTS STANDARD DRAWING	<i>William S. Valle</i> WILLIAM S. VALLE CITY ENGINEER
ORIGINAL	CVM		1/00		
REVISION	CVM	C. SWANSON	11/02		11/21/2017
REVISION	DPH	W. VALLE	11/17	MAJOR & COLLECTOR STREETS WITH NON-CONTIGUOUS SIDEWALK	RWY-02

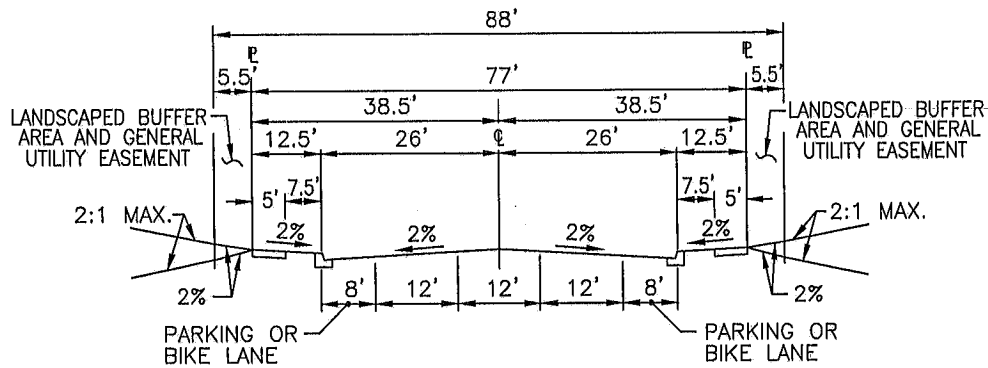

CLASS II COLLECTOR W/ NON-CONTIGUOUS SIDEWALK

NO SCALE

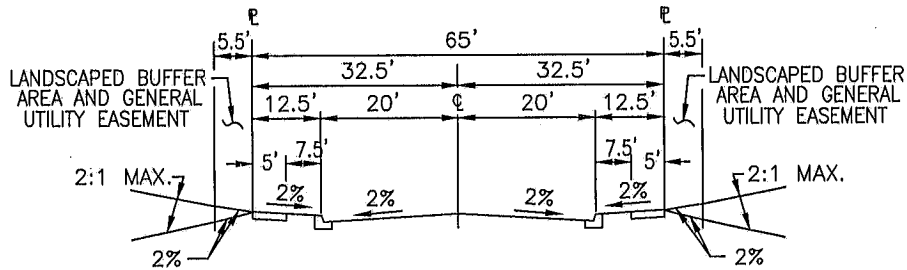

CLASS III COLLECTOR W/ NON-CONTIGUOUS SIDEWALK

NO SCALE

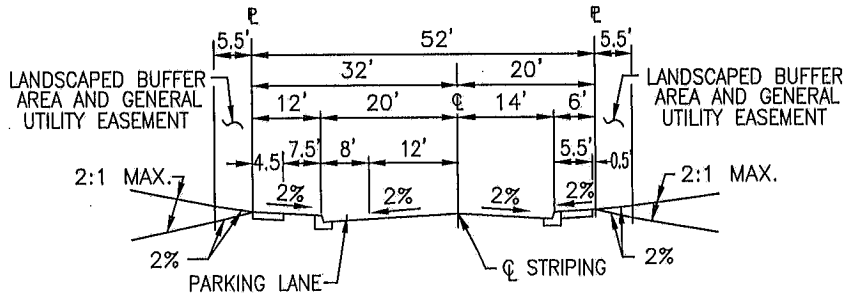

**SINGLE LOADED RESIDENTIAL
W/ NON-CONTIGUOUS SIDEWALK**

NO SCALE

NOTES:

1. REFER TO CITY OF CHULA VISTA "STREET DESIGN STANDARDS POLICY" ADOPTED BY COUNCIL RESOLUTION #15349 ON OCTOBER 17, 1989.
2. STANDARDS MAY VARY IN DEVELOPED AREAS WEST OF I-805. REFER TO "STREET DESIGN STANDARDS POLICY".
3. THIS STANDARD DRAWING IS A MODIFICATION OF RWY-01 TO USE NON-CONTIGUOUS SIDEWALKS.
4. TREES WITHIN 7.5' OR LESS OF HARDSCAPE SHALL HAVE ROOT BARRIERS AND DEEP WATER IRRIGATION.

SHEET 2 OF 3

REVISION	BY	APPROVED	DATE	CITY OF CHULA VISTA ENGINEERING & CAPITAL PROJECTS STANDARD DRAWING	
ORIGINAL	CVM		1/00	 WILLIAM S. VALLE 11/21/2017 CITY ENGINEER	
REVISION	CVM	C. SWANSON	11/02		
REVISION	DPH	W. VALLE	11/17		
				COLLECTOR & RESIDENTIAL STREETS WITH NON-CONTIGUOUS SIDEWALK	
				RWY-02	

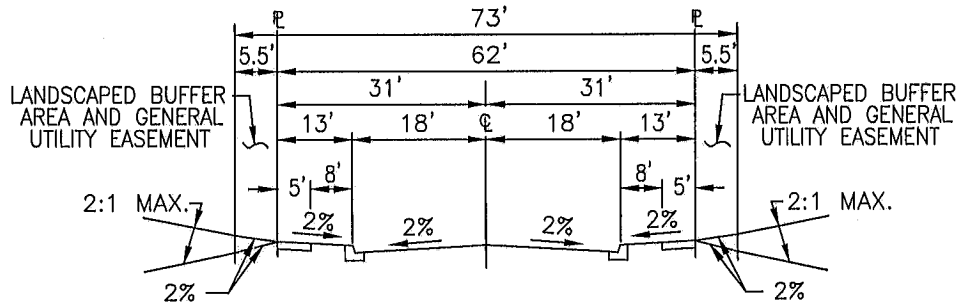

RESIDENTIAL

WITH NON-CONTIGUOUS SIDEWALKS
NO SCALE

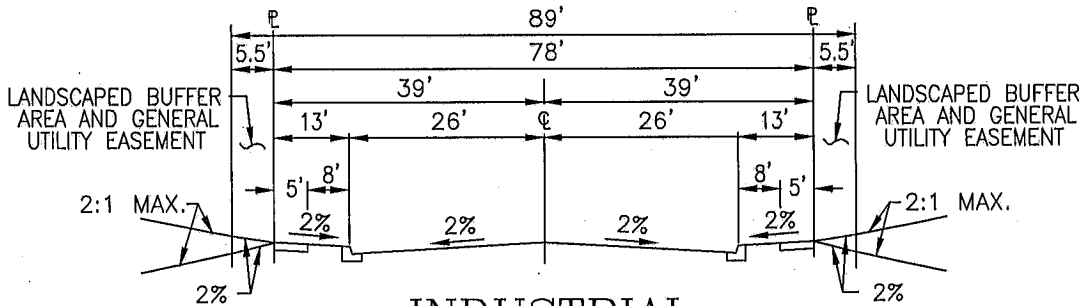

INDUSTRIAL

WITH NON-CONTIGUOUS SIDEWALKS
NO SCALE

NOTES:

1. REFER TO CITY OF CHULA VISTA "STREET DESIGN STANDARDS POLICY" ADOPTED BY COUNCIL RESOLUTION #15349 ON OCTOBER 17, 1989.
2. STANDARDS MAY VARY IN DEVELOPED AREAS WEST OF I-805. REFER TO "STREET DESIGN STANDARDS POLICY".
3. STANDARD CROSS-SECTIONS HAVE BEEN REVISED FOR NON-CONTIGUOUS SIDEWALKS.
4. TREES WITHIN 7.5' OR LESS OF HARDSCAPE SHALL HAVE ROOT BARRIERS AND DEEP WATER IRRIGATION.

SHEET 3 OF 3

REVISION	BY	APPROVED	DATE	CITY OF CHULA VISTA ENGINEERING & CAPITAL PROJECTS STANDARD DRAWING	
ORIGINAL	CVM		1/00		 WILLIAM S. VALLE 11/21/2017 CITY ENGINEER
REVISION	CVM	C. SWANSON	11/02		
REVISION	DPH	W. VALLE	11/17		
				RESIDENTIAL & INDUSTRIAL STREETS WITH NON-CONTIGUOUS SIDEWALK	RWY-02

OTAY RANCH EXPRESSWAY, PRIME AND MAJOR STREET SECTIONS

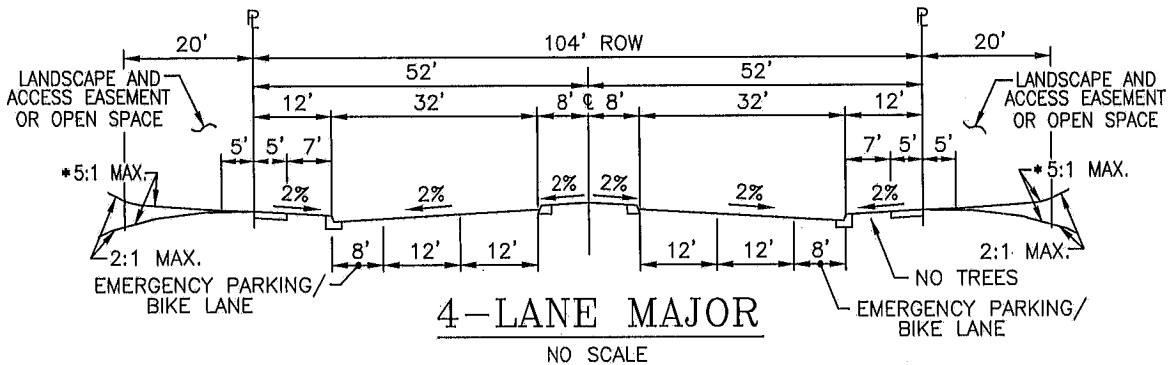
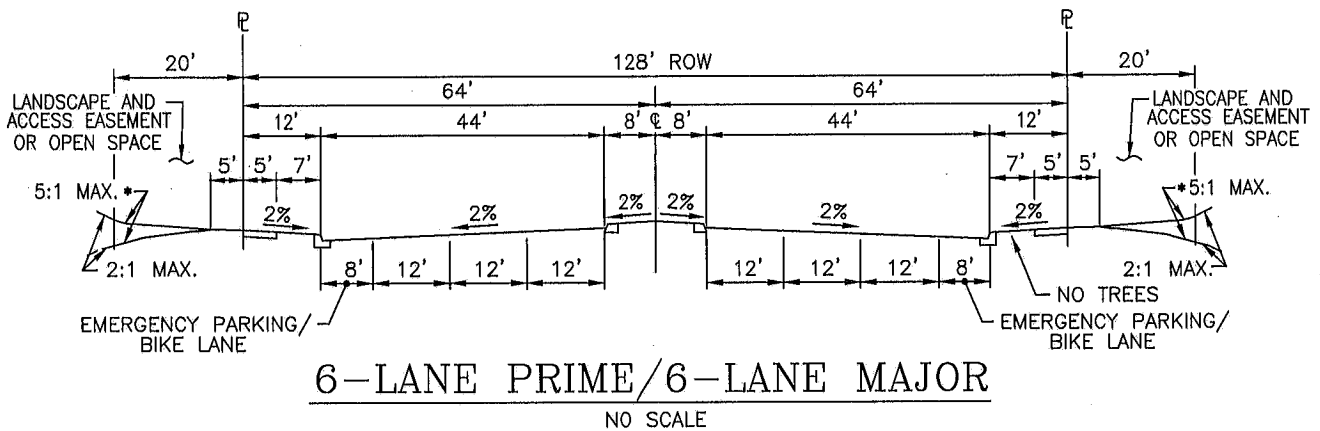
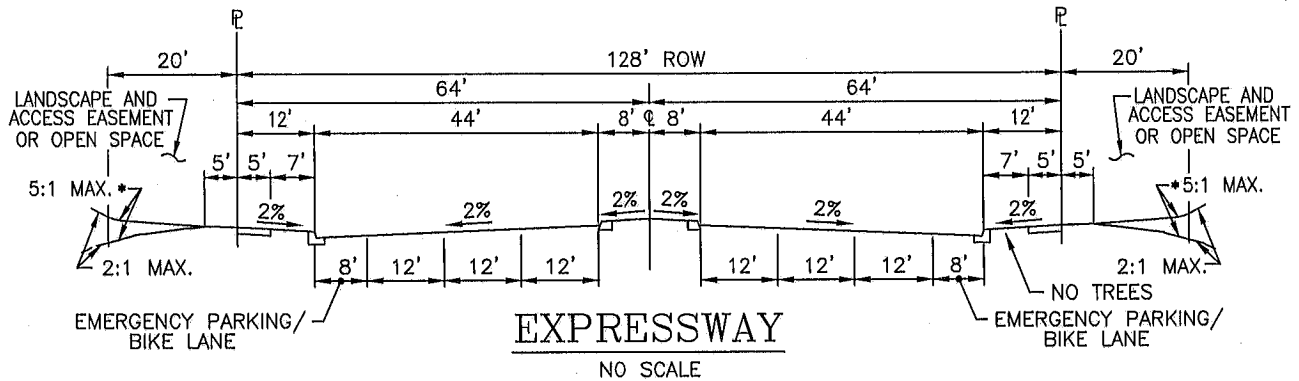

* LANDSCAPED SLOPES GREATER THAN 5:1 MAY BE ACCEPTABLE AS DETERMINED BY THE DIRECTOR OF PLANNING AND BUILDING.

NOTES:

1. THESE STANDARDS ARE FOR USE ONLY WITHIN OTAY RANCH GDP ONLY.
2. TREES WITHIN 7.5' OR LESS OF HARDSCAPE SHALL HAVE ROOT BARRIERS AND DEEP WATER IRRIGATION.
3. DIFFERENT PARKWAYS MAY BE ACCEPTABLE AS DETERMINED AT SPA AND TENTATIVE MAP APPROVAL.

SHEET 1 OF 5

REVISION	BY	APPROVED	DATE	CITY OF CHULA VISTA ENGINEERING & CAPITAL PROJECTS STANDARD DRAWING	<i>William S. Valle</i>
ORIGINAL	CVM		3/01		
REVISION	CVM	C. SWANSON	11/02		
REVISION	DPH	W. VALLE	11/17		
				OTAY RANCH – EXPRESSWAY, PRIME & MAJOR STREET SECTIONS	WILLIAM S. VALLE 11/21/2017 CITY ENGINEER
					RWY-03

OTAY RANCH VILLAGE ENTRY STREET SECTIONS

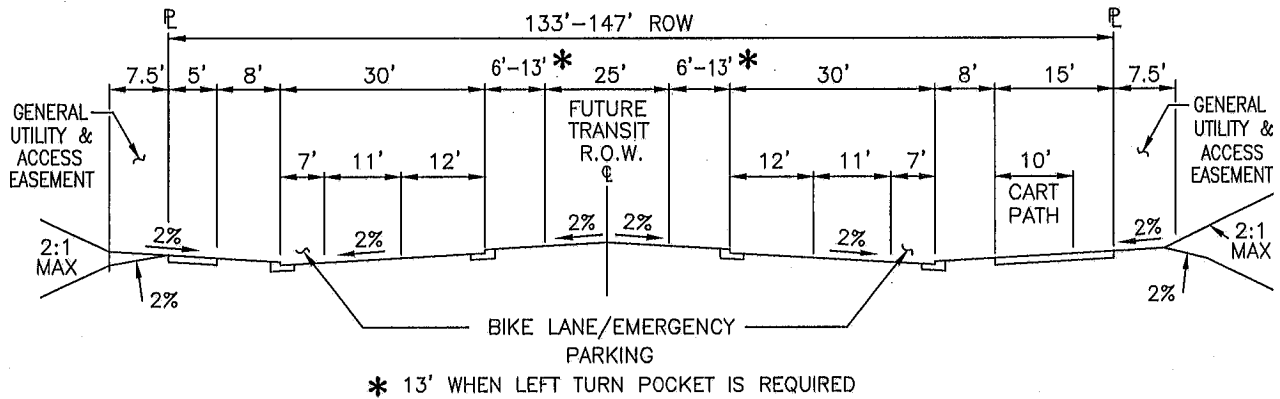

TRANSIT VILLAGE ENTRY STREET

NO SCALE

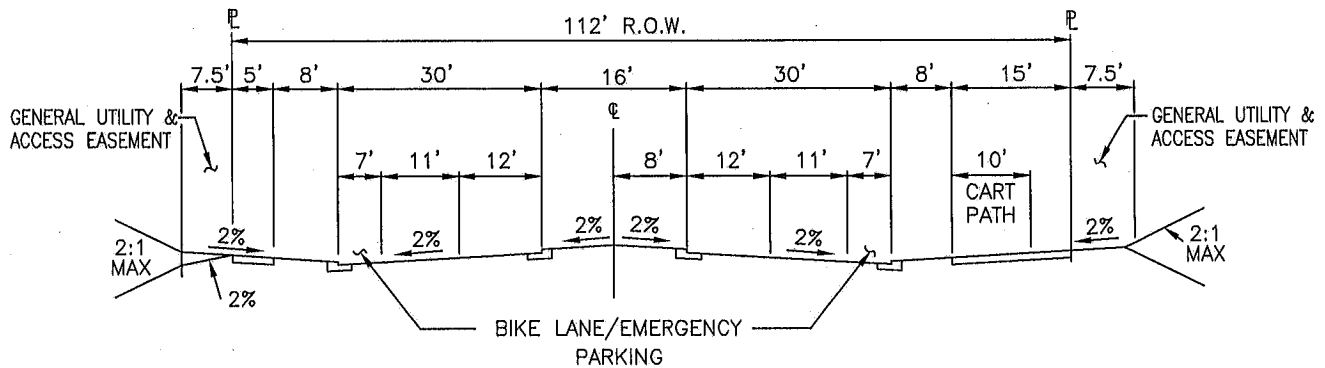

VILLAGE ENTRY STREET

NO SCALE

NOTES:

1. THESE STANDARDS ARE FOR USE ONLY WITHIN OTAY RANCH GDP ONLY.
2. TREES WITHIN 7.5' OR LESS OF HARDSCAPE SHALL HAVE ROOT BARRIERS AND DEEP WATER IRRIGATION SYSTEMS.
3. DIFFERENT PARKWAYS MAY BE ACCEPTABLE AS DETERMINED AT SPA AND TENTATIVE MAP APPROVAL.
4. PARKING WITHIN VILLAGE CORE AREAS MAY BE ACCEPTABLE AS DETERMINED BY THE CITY ENGINEER. A SUPPLEMENTAL STRIPING PLAN MAY BE WARRANTED TO IDENTIFY PARKING RESTRICTIONS.

SHEET 2 OF 5

REVISION	BY	APPROVED	DATE		
ORIGINAL	CVM		3/01	CITY OF CHULA VISTA ENGINEERING & CAPITAL PROJECTS STANDARD DRAWING	<i>William S. Valle</i> WILLIAM S. VALLE 11/21/2017 CITY ENGINEER
REVISION	CVM	C. SWANSON	11/02		
REVISION	DPH	W. VALLE	11/17		
				OTAY RANCH - VILLAGE ENTRY STREET SECTIONS	RWY-03

OTAY RANCH SECONDARY VILLAGE ENTRY STREET SECTIONS

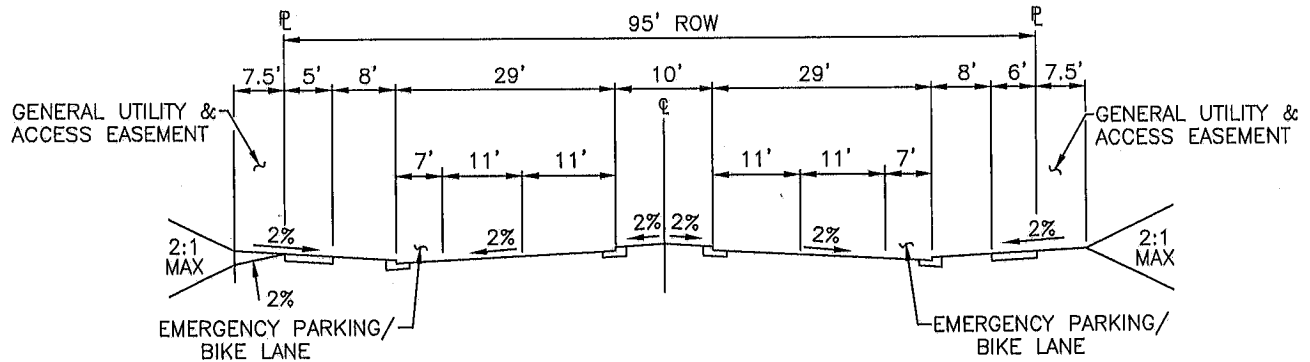

SECONDARY VILLAGE ENTRY W/ MEDIAN

NO SCALE

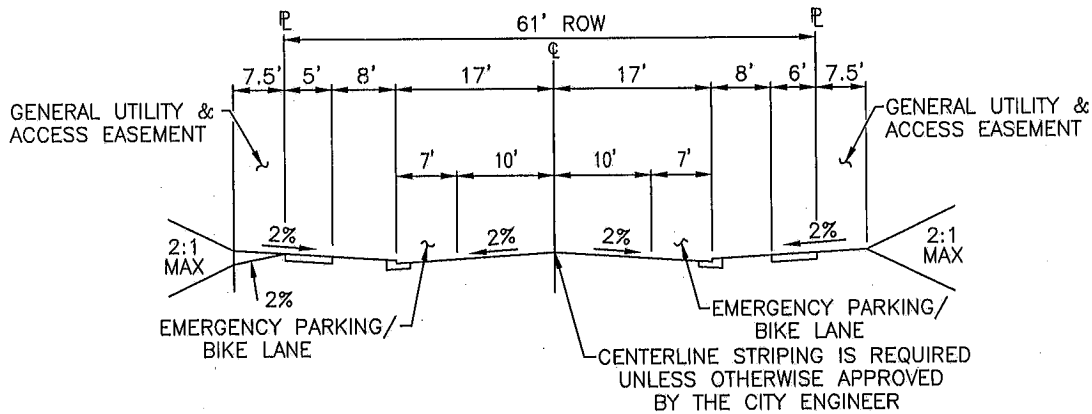

SECONDARY VILLAGE ENTRY

NO SCALE

NOTES:

1. THESE STANDARDS ARE FOR USE ONLY WITHIN OTAY RANCH GDP ONLY.
2. TREES WITHIN 7.5' OR LESS OF HARDSCAPE SHALL HAVE ROOT BARRIERS AND DEEP WATER IRRIGATION.
3. DIFFERENT PARKWAYS MAY BE ACCEPTABLE AS DETERMINED AT SPA AND TENTATIVE MAP APPROVAL.
4. EMERGENCY PARKING / BIKE LANE AND CENTERLINE STRIPING MAY BE REQUIRED AT THE IMPROVEMENT PLANS REVIEW PROCESS. STRIPING REQUIREMENTS SHALL BE AT THE DISCRETION OF THE CITY ENGINEER.

SHEET 3 OF 5

REVISION	BY	APPROVED	DATE	CITY OF CHULA VISTA ENGINEERING & CAPITAL PROJECTS STANDARD DRAWING	<i>William S. Valle</i>
ORIGINAL	CVM		3/01		
REVISION	CVM	C. SWANSON	11/02		
REVISION	DPH	W. VALLE	11/17		
				OTAY RANCH – SECONDARY VILLAGE ENTRY STREET SECTIONS	WILLIAM S. VALLE 11/21/2017 CITY ENGINEER
					RWY-03

OTAY RANCH – PROMENADE STREET SECTIONS

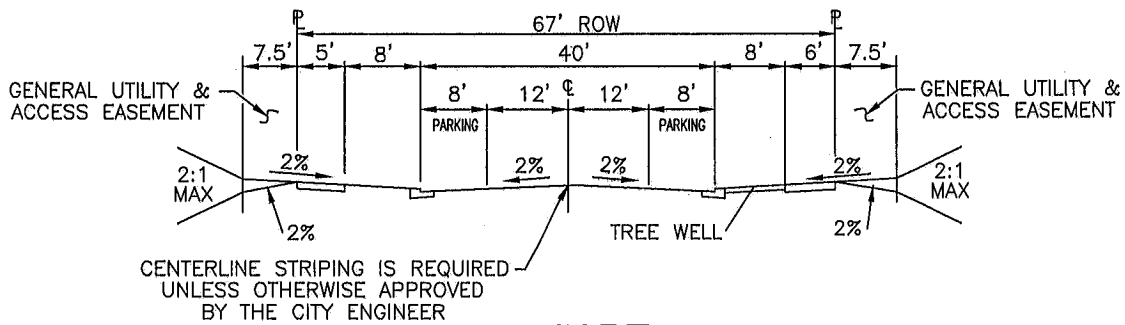

CORE
NO SCALE

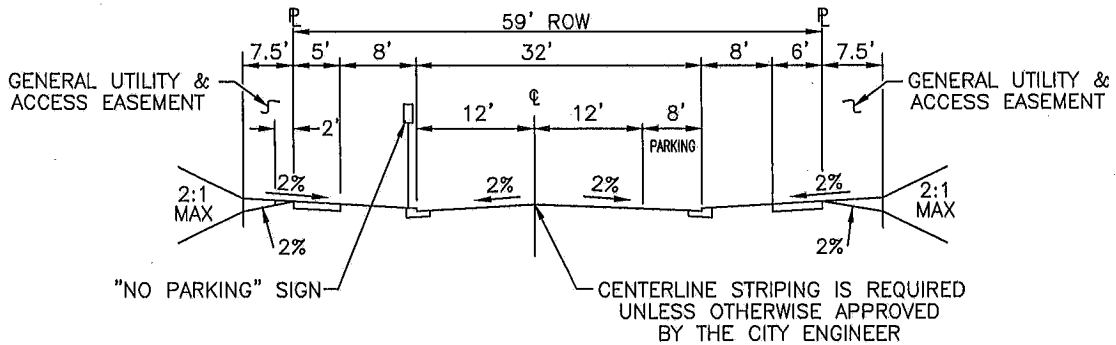

RESIDENTIAL STREET
NO SCALE

NOTES:

1. THESE STANDARDS ARE FOR USE ONLY WITHIN OTAY RANCH GDP ONLY.
2. TREES WITHIN 7.5' OR LESS OF HARDSCAPE SHALL HAVE ROOT BARRIERS AND DEEP WATER IRRIGATION.
3. TRANSITION FROM RESIDENTIAL PROMENADE TO CORE PROMENADE BEFORE REACHING LAND—USES WITH TRAFFIC GENERATION HIGHER THAN SINGLE FAMILY.
4. DIFFERENT PARKWAYS MAY BE ACCEPTABLE AS DETERMINED AT SPA AND TENTATIVE MAP APPROVAL.
5. EMERGENCY PARKING / BIKE LANE AND CENTERLINE STRIPING MAY BE REQUIRED AT THE IMPROVEMENT PLANS REVIEW PROCESS. STRIPING REQUIREMENTS SHALL BE AT THE DISCRETION OF THE CITY ENGINEER.

SHEET 4 OF 5

REVISION	BY	APPROVED	DATE	CITY OF CHULA VISTA ENGINEERING & CAPITAL PROJECTS STANDARD DRAWING	<i>William S. Valle</i>
ORIGINAL	CVM		4/02		
REVISION	CVM	C. SWANSON	11/02		
REVISION	DPH	W. VALLE	11/17	OTAY RANCH – PROMENADE STREET SECTIONS	WILLIAM S. VALLE 11/21/2017 CITY ENGINEER
					RWY-03

OTAY RANCH - STREET SECTIONS

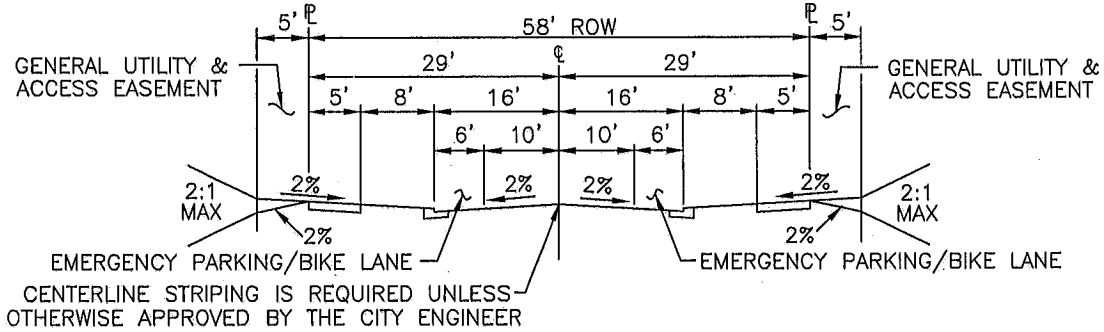

PARKWAY RESIDENTIAL

NO SCALE

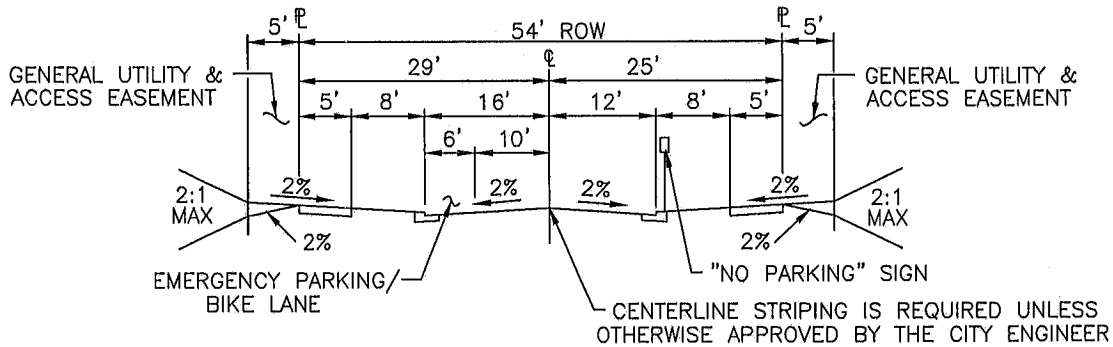

SINGLE LOADED PARKWAY RESIDENTIAL

NO SCALE

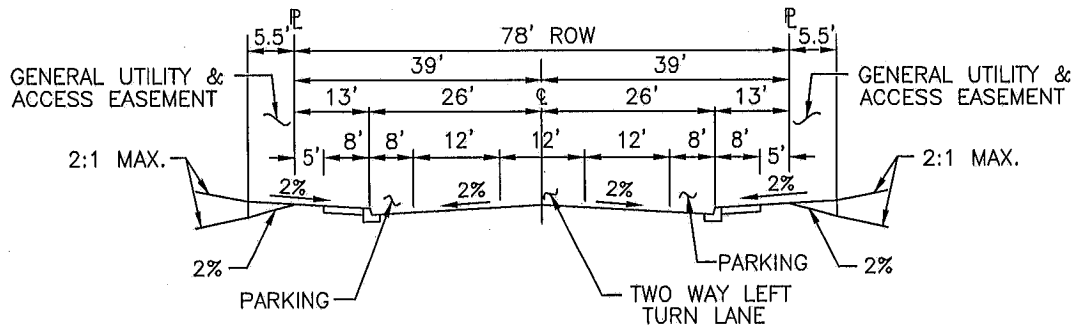

INDUSTRIAL

NO SCALE

NOTES:

1. THESE STANDARDS ARE FOR USE ONLY WITHIN OTAY RANCH GDP.
2. TREES WITHIN 7.5' OR LESS OF HARDSCAPE SHALL HAVE ROOT BARRIERS AND DEEP WATER IRRIGATION.
3. DIFFERENT PARKWAYS MAY BE ACCEPTABLE AS DETERMINED AT SPA AND TENTATIVE MAP APPROVAL.
4. EMERGENCY PARKING / BIKE LANE AND CENTERLINE STRIPING MAY BE REQUIRED AT THE IMPROVEMENT PLANS REVIEW PROCESS. STRIPING REQUIREMENTS SHALL BE AT THE DISCRETION OF THE CITY ENGINEER.

SHEET 5 OF 5

REVISION	BY	APPROVED	DATE	CITY OF CHULA VISTA ENGINEERING & CAPITAL PROJECTS STANDARD DRAWING	<i>William S. Valle</i> WILLIAM S. VALLE CITY ENGINEER
ORIGINAL	CVM		4/02		
REVISION	CVM	C. SWANSON	11/02		
REVISION	DPH	W. VALLE	11/17		
				OTAY RANCH - PKWY, RESIDENTIAL, & INDUSTRIAL ST SECTIONS	11/21/2017
					RWY-03

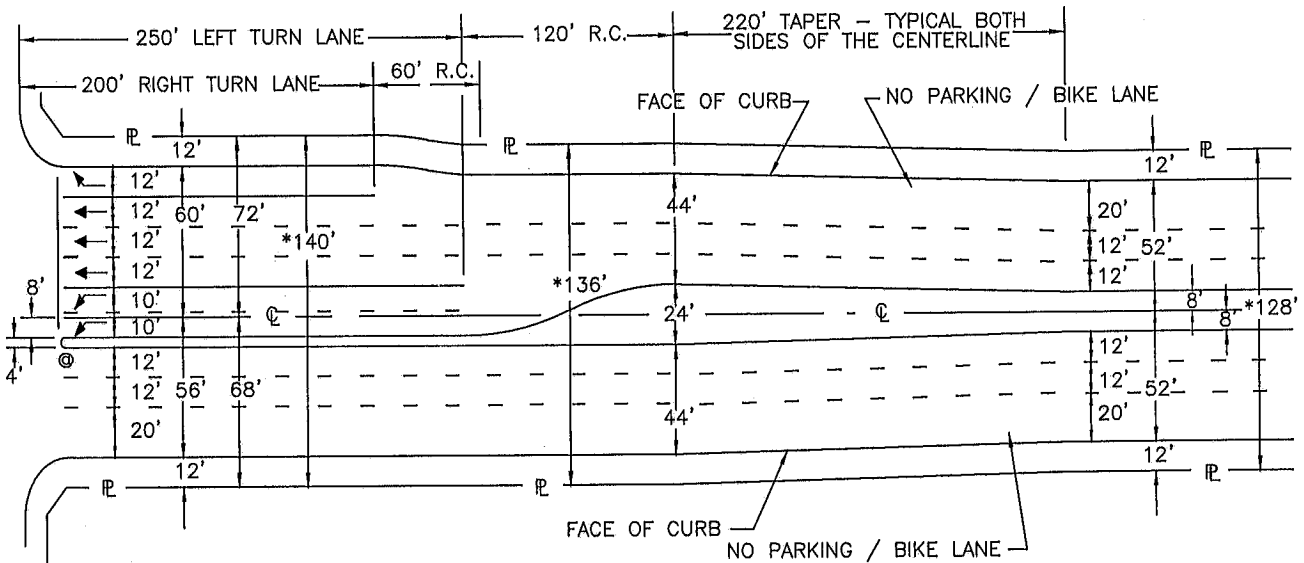

NOTE: * IF THIS IS A DESIGNATED BIKE LANE ON THE GENERAL PLAN,
AN ADDITIONAL 10' RIGHT-OF-WAY WILL BE REQUIRED.

⊙ MEDIAN NOSE AT PCR STATION

PRIME

NO SCALE

(WITH RIGHT TURN LANE AND DUAL LEFT TURN LANES)

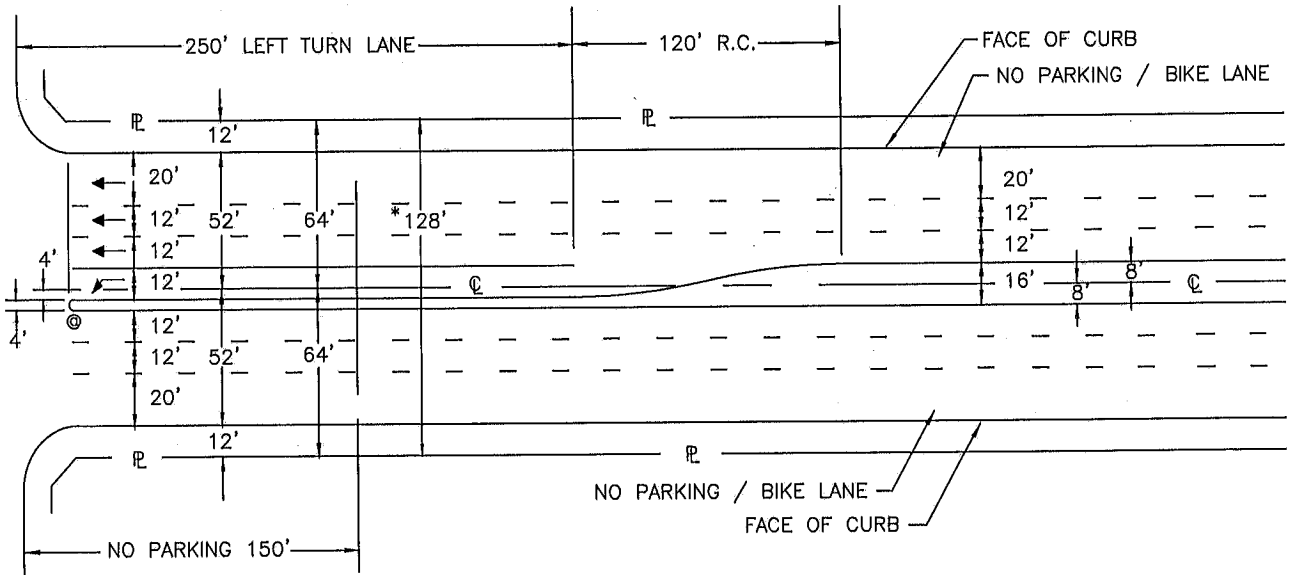

NOTE: * IF THIS IS A DESIGNATED BIKE LANE ON THE GENERAL PLAN,
AN ADDITIONAL 10' RIGHT-OF-WAY WILL BE REQUIRED.

⊙ MEDIAN NOSE AT PCR STATION

PRIME

NO SCALE

(WITH SINGLE LEFT TURN LANE)

SHEET 1 OF 6

REVISION	BY	APPROVED	DATE
ORIGINAL			2/90
REVISION	CM	C. SWANSON	11/02
REVISION	DPH	W. VALLE	11/17

CITY OF CHULA VISTA
ENGINEERING & CAPITAL PROJECTS
STANDARD DRAWING

6-LANE PRIME INTERSECTION
STANDARDS

William S. Valle
WILLIAM S. VALLE 11/21/2017
CITY ENGINEER

RWY-04

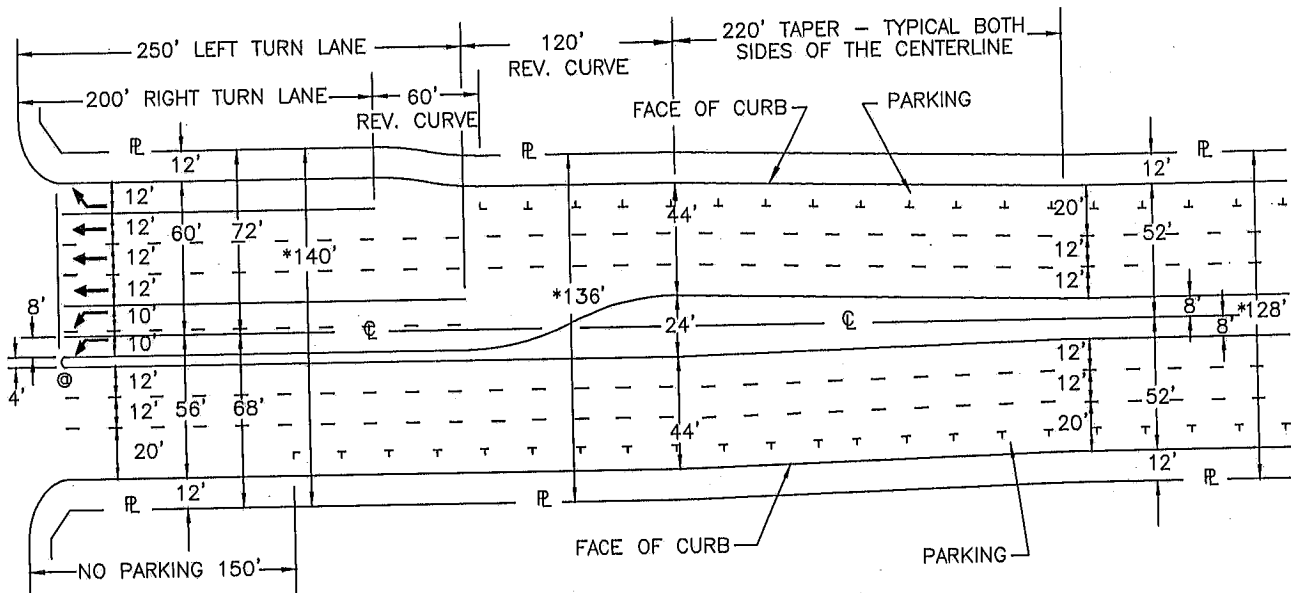

NOTES: * IF THIS IS A DESIGNATED BIKE LANE ON THE GENERAL PLAN,
AN ADDITIONAL 10' RIGHT-OF-WAY WILL BE REQUIRED.
⊙ MEDIAN NOSE AT PCR STATION.

6-LANE MAJOR
NO SCALE
(WITH RIGHT TURN LANE AND DUAL LEFT TURN LANES)

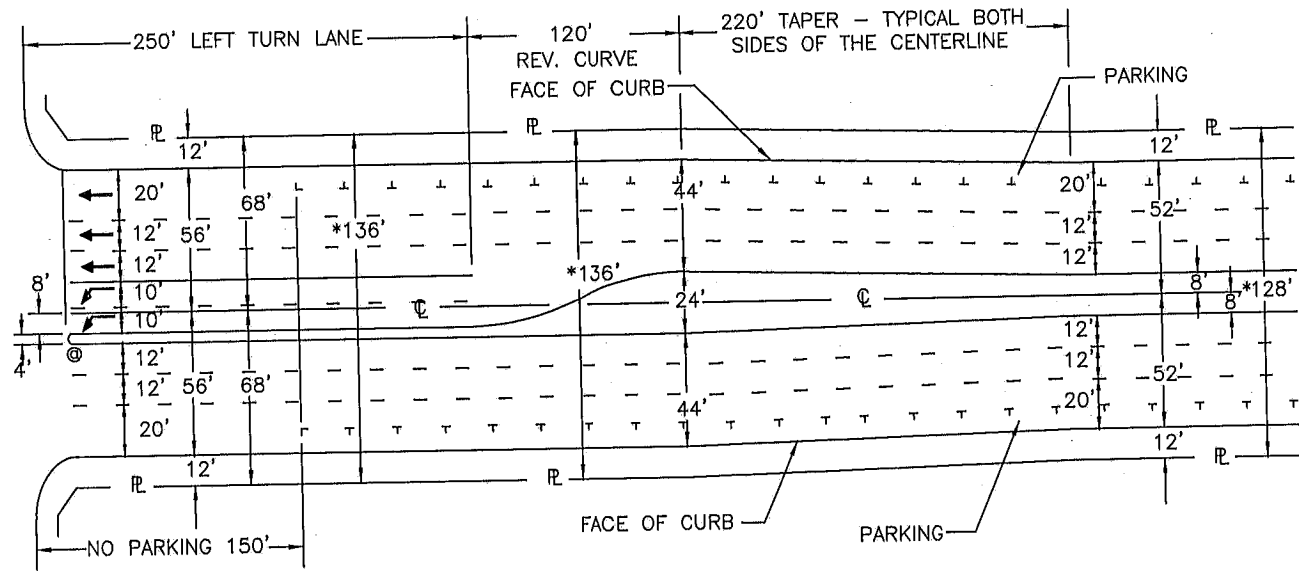

NOTES: * IF THIS IS A DESIGNATED BIKE LANE ON THE GENERAL PLAN,
AN ADDITIONAL 10' RIGHT-OF-WAY WILL BE REQUIRED.
⊙ MEDIAN NOSE AT PCR STATION.

6-LANE MAJOR
NO SCALE
(WITH DUAL LEFT TURN LANES)

REVISION	BY	APPROVED	DATE
ORIGINAL			2/90
REVISION	CM	C. SWANSON	11/02
REVISION	DPH	W. VALLE	11/17

CITY OF CHULA VISTA
ENGINEERING & CAPITAL PROJECTS
STANDARD DRAWING

6-LANE MAJOR INTERSECTION
STANDARDS

William S. Valle
WILLIAM S. VALLE 11/21/2017
CITY ENGINEER

RWY-04

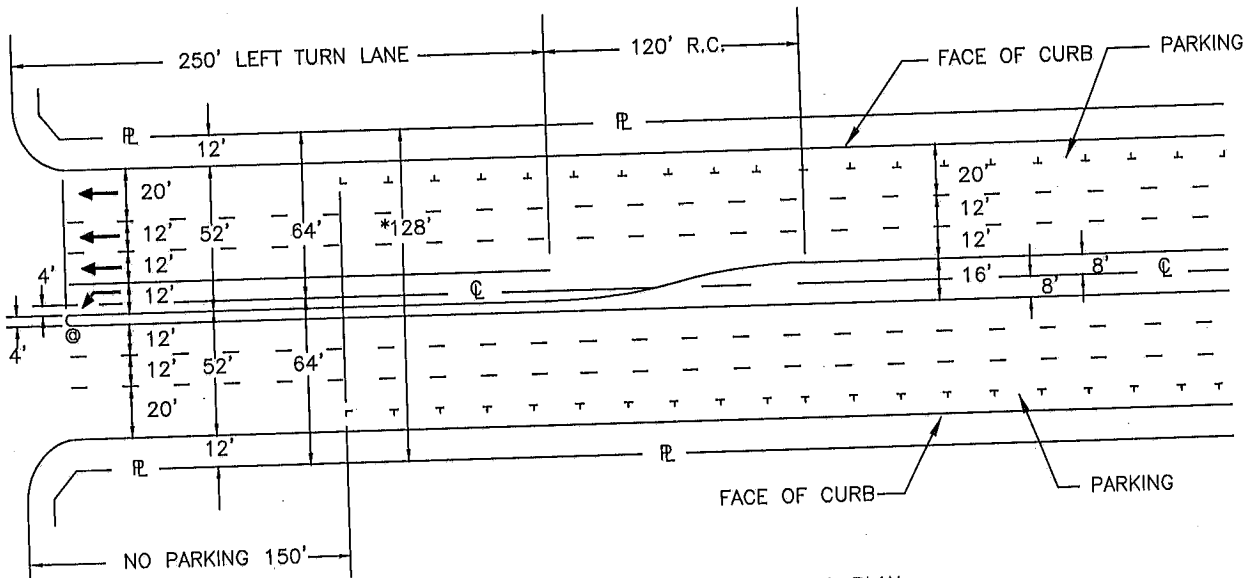

NOTES: * IF THIS IS A DESIGNATED BIKE LANE ON THE THE GENERAL PLAN,
AN ADDITIONAL 10' OF RIGHT-OF-WAY WILL BE REQUIRED.
⊙ MEDIAN NOSE AT PCR STATION.

6 - LANE MAJOR
NO SCALE
(WITH SINGLE LEFT TURN LANE)

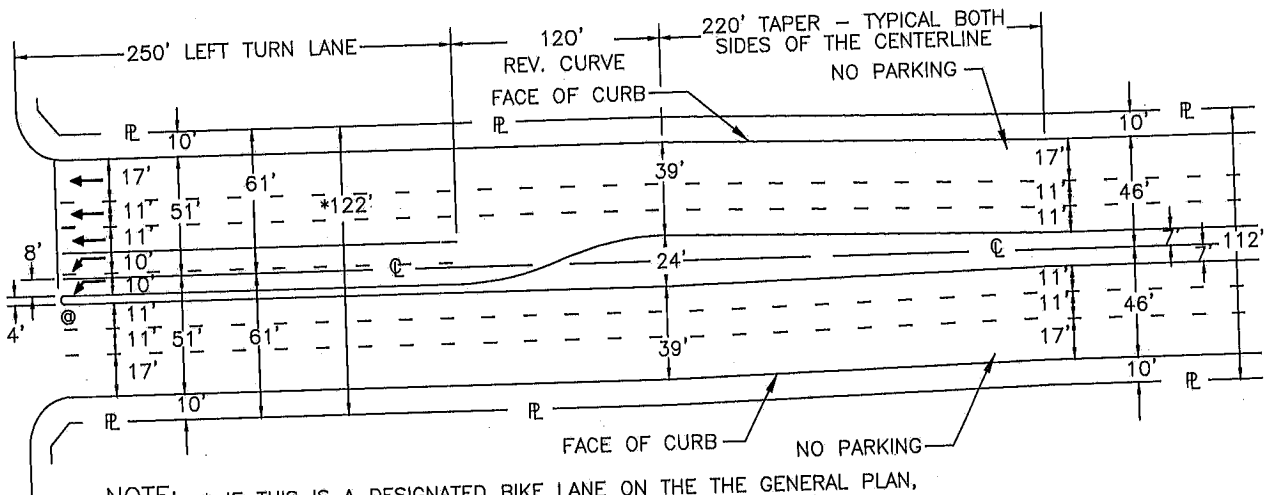

NOTE: * IF THIS IS A DESIGNATED BIKE LANE ON THE THE GENERAL PLAN,
AN ADDITIONAL 10' OF RIGHT-OF-WAY WILL BE REQUIRED.
⊙ MEDIAN NOSE AT PCR STATION.

6 - LANE MAJOR
NO SCALE
ONLY IN DEVELOPED AREAS WEST OF I-805
(WITH DUAL LEFT TURN LANES)

SHEET 3 OF 6

REVISION	BY	APPROVED	DATE
ORIGINAL			2/90
REVISION	CM	C. SWANSON	11/02
REVISION	DPH	W. VALLE	11/17

CITY OF CHULA VISTA
ENGINEERING & CAPITAL PROJECTS
STANDARD DRAWING
6-LANE MAJOR INTERSECTION
STANDARDS 2

William S. Valle
WILLIAM S. VALLE 11/21/2017
CITY ENGINEER
RWY-04

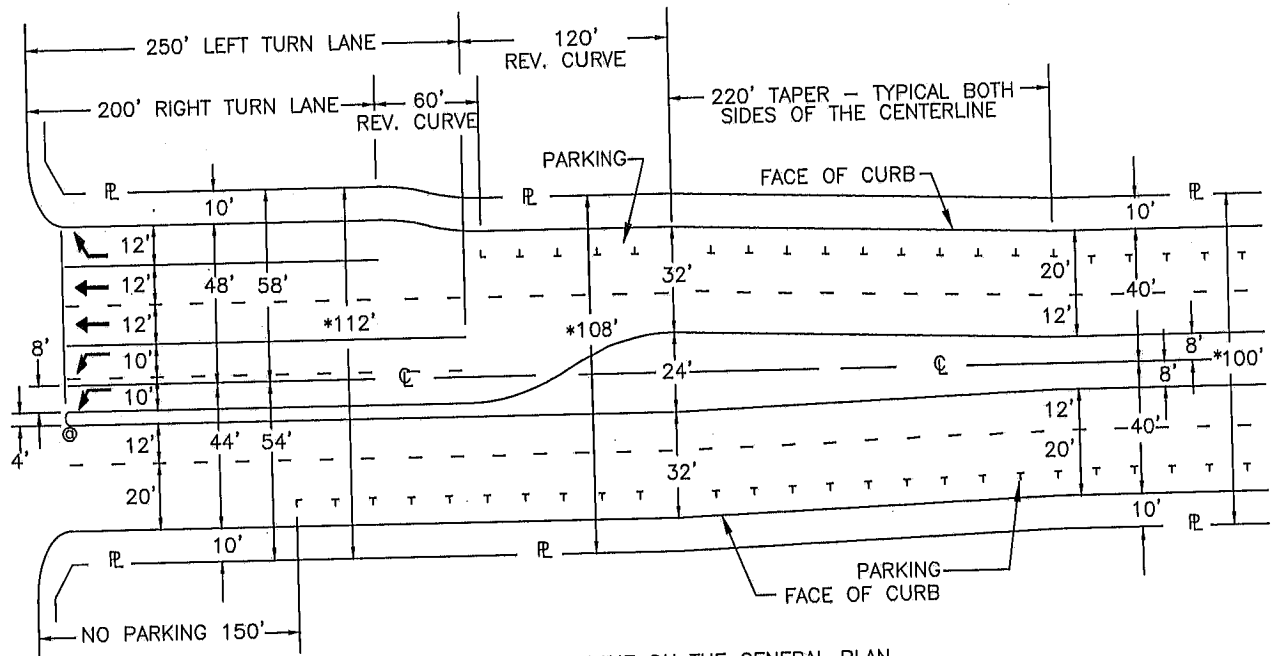

NOTES: * IF THIS IS A DESIGNATED BIKE LANE ON THE GENERAL PLAN AN ADDITIONAL 10' OF RIGHT-OF-WAY WILL BE REQUIRED.
 © MEDIAN NOSE AT PCR STATION.

4-LANE MAJOR

NO SCALE

(WITH RIGHT TURN LANE AND DUAL LEFT TURN LANES)

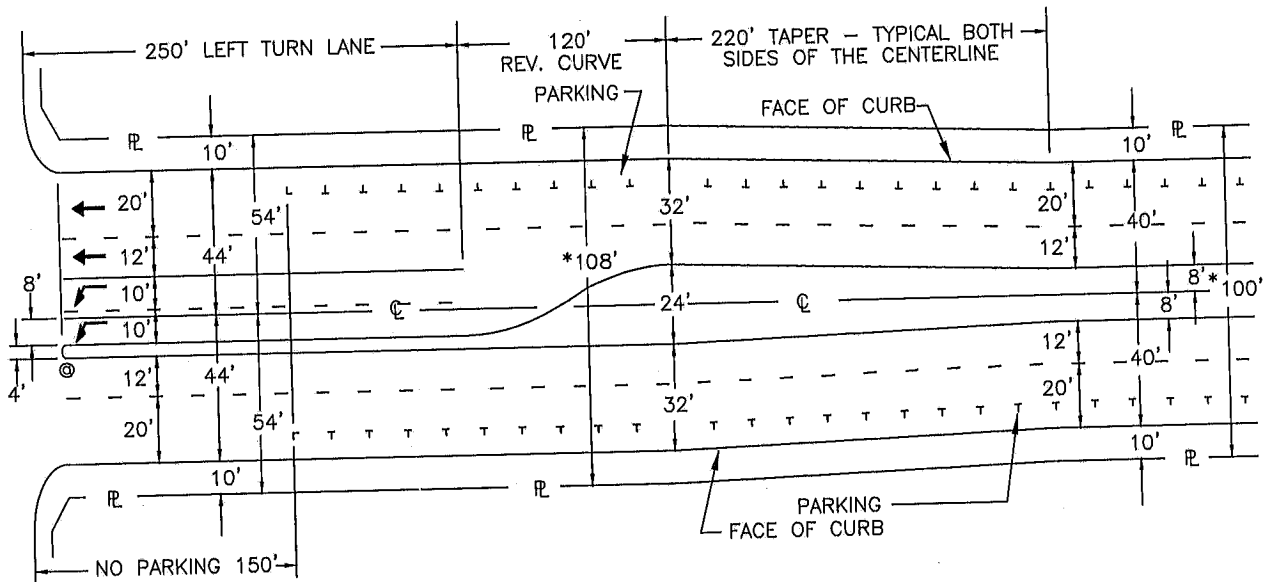

NOTES: * IF THIS IS A DESIGNATED BIKE LANE ON THE GENERAL PLAN AN ADDITIONAL 10' OF RIGHT-OF-WAY WILL BE REQUIRED.
 © MEDIAN NOSE AT PCR STATION.

4-LANE MAJOR

NO SCALE

(WITH DUAL LEFT TURN LANES)

REVISION	BY	APPROVED	DATE
ORIGINAL			2/90
REVISION	CM	C. SWANSON	11/02
REVISION	DPH	W. VALLE	11/17

CITY OF CHULA VISTA
 ENGINEERING & CAPITAL PROJECTS
 STANDARD DRAWING

William S. Valle
 WILLIAM S. VALLE 11/21/2017
 CITY ENGINEER

4-LANE MAJOR INTERSECTION
 STANDARDS

RWY-04

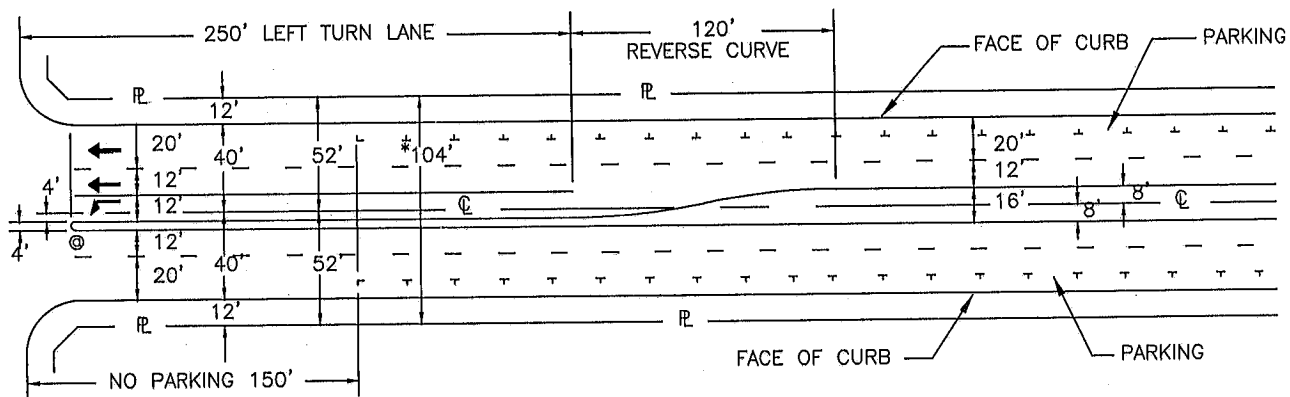

NOTES: * IF THIS IS A DESIGNATED BIKE LANE ON THE GENERAL PLAN AN ADDITIONAL 10' OF RIGHT-OF-WAY WILL BE REQUIRED.
 © MEDIAN NOSE AT PCR STATION.

4-LANE MAJOR
 NO SCALE (WITH SINGLE LEFT TURN LANE)

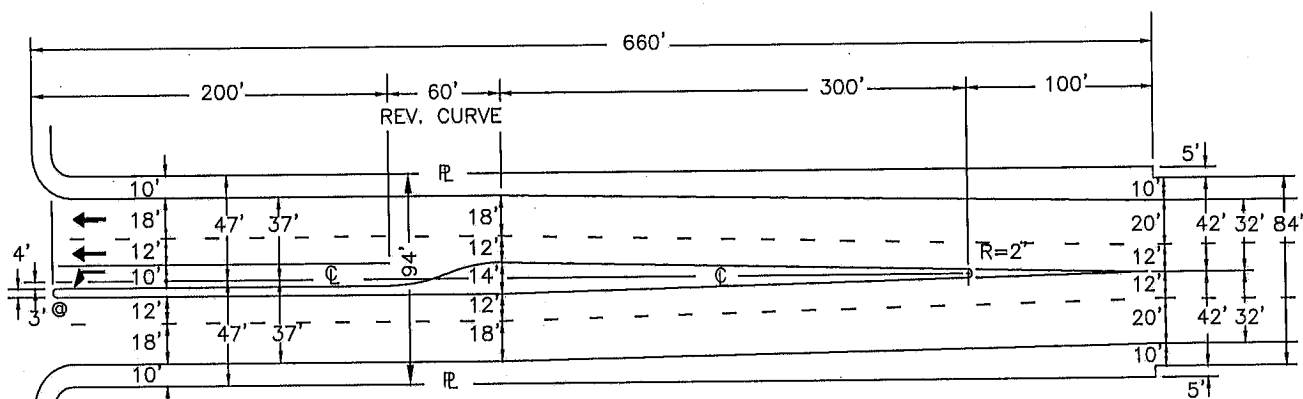

NOTES: WIDEN STREET INTERSECTION AS SHOWN WHEN INTERSECTING A CLASS I COLLECTOR STREET OR HIGHER.

© MEDIAN NOSE AT PCR STATION.

CLASS I COLLECTOR STREET
 NO SCALE (ONLY IN DEVELOPED AREAS WEST OF I-805)

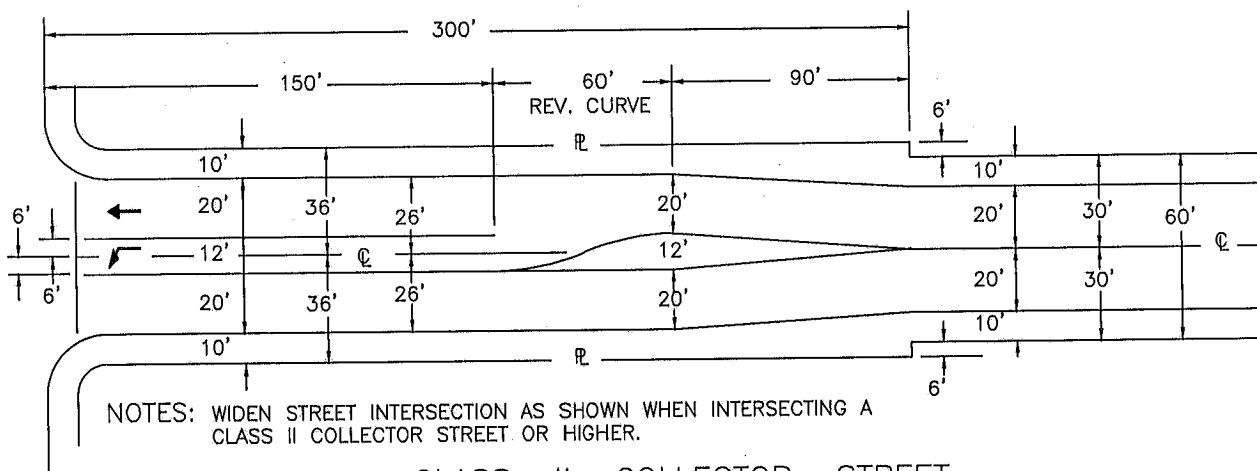

NOTES: WIDEN STREET INTERSECTION AS SHOWN WHEN INTERSECTING A CLASS II COLLECTOR STREET OR HIGHER.

CLASS II COLLECTOR STREET
 NO SCALE (ONLY IN DEVELOPED AREAS WEST OF I-805)

REVISION	BY	APPROVED	DATE
ORIGINAL			2/90
REVISION	CM	C. SWANSON	11/02
REVISION	DPH	W. VALLE	11/17

CITY OF CHULA VISTA
 ENGINEERING & CAPITAL PROJECTS
 STANDARD DRAWING

4-LANE MAJOR & COLLECTOR
 INTERSECTION STANDARDS

William S. Valle
 WILLIAM S. VALLE 11/21/2017
 CITY ENGINEER

RWY-04

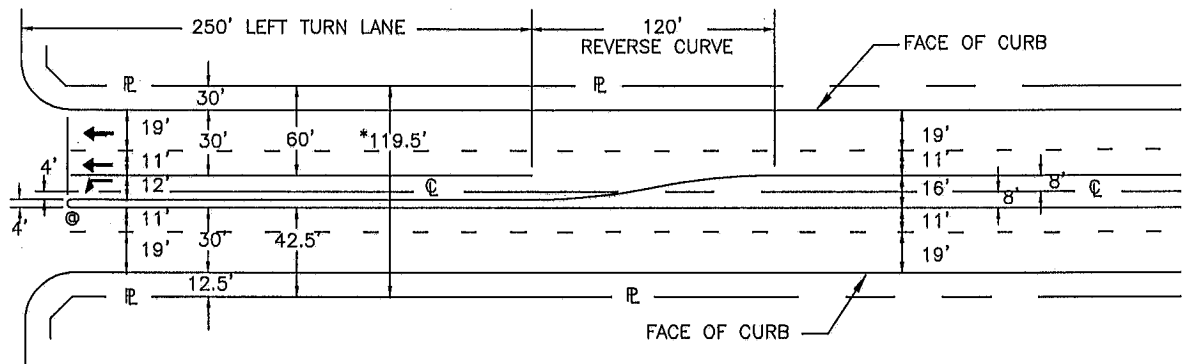

VILLAGE ENTRY STREET
NO SCALE (WITH SINGLE LEFT TURN LANE)

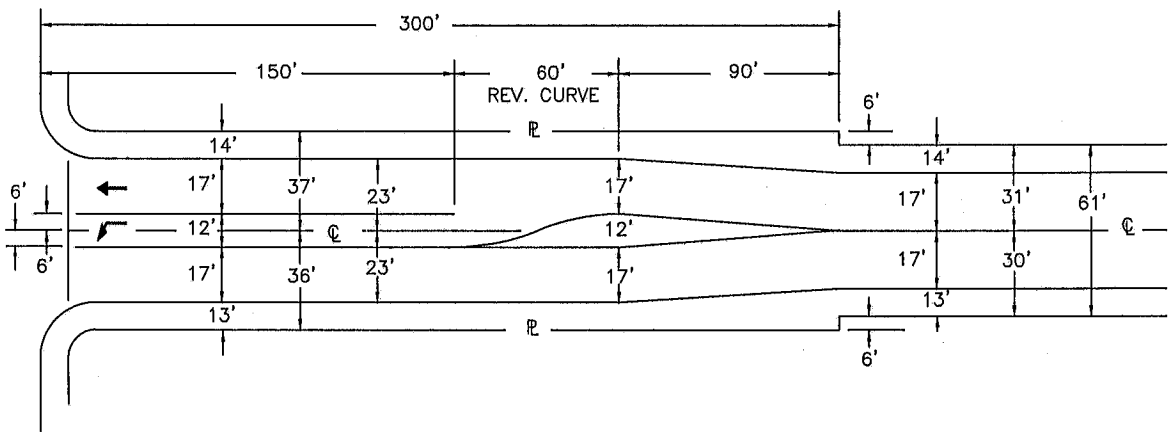

SECONDARY VILLAGE ENTRY
NO SCALE

SHEET 6 OF 6

REVISION	BY	APPROVED	DATE
ORIGINAL	CVM		2/00
REVISION	CM	C. SWANSON	11/02
REVISION	DPH	W. VALLE	11/17

CITY OF CHULA VISTA
ENGINEERING & CAPITAL PROJECTS
STANDARD DRAWING

OTAY RANCH — VILLAGE
INTERSECTION STANDARDS

William S. Valle
WILLIAM S. VALLE 11/21/2017
CITY ENGINEER

RWY-04

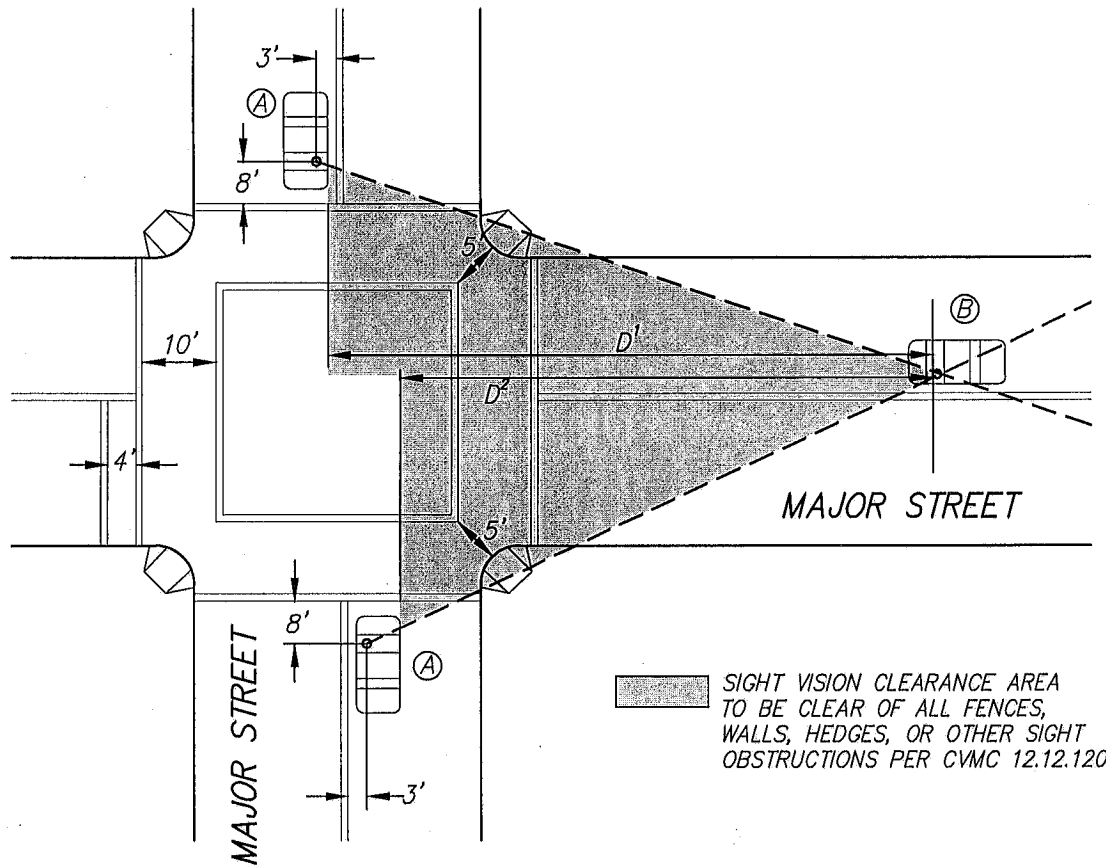

REQUIRED SIGHT DISTANCE *		
DESIGN OR 85TH PERCENTILE SPEED (IN M.P.H.)	CORNER SIGHT DISTANCE (D ¹ & D ²) FROM LOCATION (A)	STOPPING SIGHT DISTANCE (D ¹ & D ²) FROM LOCATION (B)
25	280	155
30	335	200
35	390	250
40	445	305
45	500	360
50	555	425
55	610	495
60	665	570
65	720	645
70	775	730

* SIGHT DISTANCE FOR LEVEL GRADE (3% OR LESS)

(SEE SHEET 2 FOR ADDITIONAL NOTES)

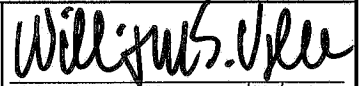
REVISION	BY	APPROVED	DATE	CITY OF CHULA VISTA ENGINEERING & CAPITAL PROJECTS STANDARD DRAWING	 WILLIAM S. VALLE CITY ENGINEER
ORIGINAL	CVM	C. SWANSON	11/02		
REVISION	DPH	W. VALLE	11/17		
SIGHT DISTANCE REQUIREMENTS					11/21/2017
					RWY-05

CORNER SIGHT DISTANCE IS DEFINED AS THE SIGHT DISTANCE NEEDED TO ALLOW 7 1/2 SECONDS OF REACTION TIME FOR THE DRIVER OF A VEHICLE STOPPED AT POINT "A" TO PROCEED THRU THE INTERSECTION WHILE THE APPROACHING VEHICLE (POINT "B") TRAVELS AT THE ASSUMED DESIGN SPEED, OR THE 85 PERCENTILE SPEED (WHICHEVER IS HIGHER), OF THE MAJOR ROADWAY.

CORNER SIGHT DISTANCE SHALL (1) BE MEASURED ALONG THE PATH OF THE APPROACHING VEHICLE TO A PROJECTED POINT OF COLLISION BETWEEN VEHICLES, ASSUMING THAT BOTH VEHICLES PROCEED STRAIGHT AHEAD AND (2) SHALL COMPLY WITH THE TABLE PROVIDED ON THE PREVIOUS PAGE, BASED ON THE MINIMUM DESIGN SPEED OF THE ROADWAY, OR THE 85th PERCENTILE SPEED, WHICHEVER IS HIGHER. THIS SIGHT DISTANCE IS MEASURED FROM A 3.5 FOOT EYE HEIGHT ON THE MINOR ROAD TO A 4.25 FOOT OBJECT HEIGHT ON THE MAJOR ROAD.

STOPPING SIGHT DISTANCE IS DEFINED AS THE DISTANCE REQUIRED BY THE DRIVER AT POINT "B", TRAVELING AT A GIVEN SPEED, TO BRING THEIR VEHICLE TO A STOP AFTER AN OBJECT ON THE ROAD BECOMES VISIBLE. STOPPING SIGHT DISTANCE IS MEASURED FROM A 3.5 FOOT EYE HEIGHT ON THE MAJOR ROAD TO AN OBJECT 0.5 FEET HIGH ON THE MINOR ROAD.

ADDITIONAL SIGHT DISTANCE NOTES:

- 1) THE SIGHT DISTANCE REQUIREMENTS SHALL BE INCREASED BY 20% ON SUSTAINED DOWNGRADES STEEPER THAN 3% AND LONGER THAN 1 MILE.
- 2) IN CASES OF RIGHT-OF-WAY CONFLICTS, WHERE EXTENSIVE EXCAVATION IS REQUIRED OR FOR THE PRESERVATION OF WETLANDS, HISTORIC OR ARCHAEOLOGICAL SITES, A LESSER VALUE FOR CORNER SIGHT DISTANCE MAYBE USED. BUT THE MINIMUM VALUE SHALL BE THE STOPPING SIGHT DISTANCE GIVEN IN THE PREVIOUS PAGE, MEASURED FROM A 3.5 FOOT EYE HEIGHT ON THE MINOR ROAD TO A 4.5 FOOT EYE HEIGHT ON THE MAJOR ROAD. USE OF THIS MINIMUM SIGHT DISTANCE MUST BE SPECIFICALLY APPROVED BY THE CITY ENGINEER OR THEIR DESIGNEE.
- 3) AT SIGNALIZED INTERSECTIONS, THE STOPPING SIGHT DISTANCE REQUIREMENTS SHALL BE USED.

STRIPING NOTES:

CROSSWALK LIMITS: UNLESS OTHERWISE APPROVED BY THE CITY ENGINEER, THE FRONT OF THE CROSSWALK SHALL BE ESTABLISHED BETWEEN POINTS 5 FEET OUT FROM THE FACE OF CURB ON RADIAL LINES ESTABLISHED ALONG THE PROJECTED CENTERLINES OF THE CURB RETURNS. THE BACK OF THE CROSSWALK SHALL BE ESTABLISHED 11 FEET BACK FROM THE FRONT LINE OF THE CROSSWALK MEASURED ALONG A LINE PERPENDICULAR TO THE FRONT LINE.

STOPPING LIMIT LINE: AT SIGNALIZED INTERSECTIONS, WHERE SCHOOL CROSSING ARE ESTABLISHED, AND/OR WHERE STRIPING PLANS INDICATE, A STOPPING LIMIT LINE SHALL BE ESTABLISHED 4 FEET BACK FROM THE CROSSWALK.

THE CRITICAL LINE OF SIGHT SHALL BE ESTABLISHED BETWEEN POINT "A" ON THE MINOR STREET AND POINT "B" ON THE MAJOR STREET. POINT "A" SHALL BE THAT POINT MEASURED 8 FEET BACK FROM EITHER THE BACK OF THE STOPPING LIMIT LINE, IF ONE EXISTS, OR THE BACK LINE OF THE CROSSWALK AND 3 FEET FROM THE LANE LINE STRIPE OR THE PAINTED CENTER LINE OF THE MINOR STREET. POINT "B" SHALL BE THAT POINT, BEING THE END POINT OF EITHER LINE D1 OR D2, MEASURED THE DISTANCE GIVEN IN THE REQUIRED SIGHT DISTANCE TABLE AND 3 FEET FROM THE LANE LINE STRIPE OR THE PAINTED CENTER LINE OF THE MAJOR STREET. THE CRITICAL LINE OF SIGHT IS THAT LINE WHICH OFFERS THE MOST RESTRICTIVE POINT OF VISION.

SIGHT VISION CLEARANCE AREA NOTES:

PER CHULA VISTA MUNICIPAL CODE SECTION 12.12.120, ALL FENCES WALLS, HEDGES, OR OTHER OBSTRUCTIONS TO VISION THAT ARE LOCATED WITHIN SIGHT VISION TRIANGLE SHALL BE LIMITED TO A MAXIMUM HEIGHT OF 3 FEET, MEASURED FROM EVERY POINT ALONG THE OUTER EDGE OF THE PAVED SURFACE OF THE ROADWAY.

REVISION	BY	APPROVED	DATE	CITY OF CHULA VISTA ENGINEERING & CAPITAL PROJECTS STANDARD DRAWING	 WILLIAM S. VALLE CITY ENGINEER
ORIGINAL	CVM	C. SWANSON	11/02		
REVISION	DPH	W. VALLE	11/17		
				SIGHT DISTANCE REQUIREMENTS	11/21/2017
				ADDITIONAL NOTES	RWY-05

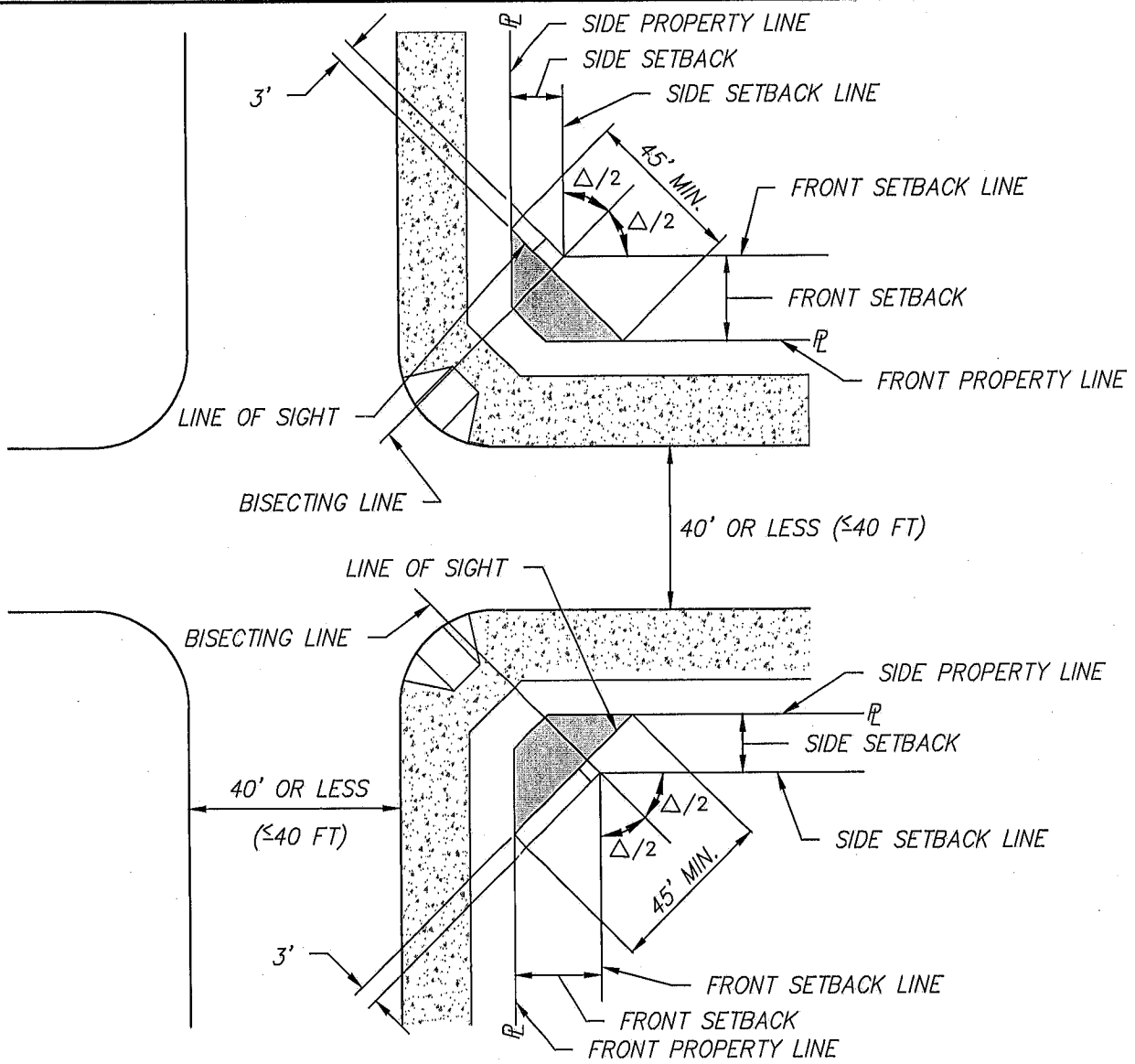

 SIGHT VISION CLEARANCE AREA

NOTES:

- 1) FRONT AND SIDE SETBACKS ARE ESTABLISHED BY THE PLANNING AND BUILDING DEPARTMENT, AND SHALL SERVE AS THE BASIS FOR DETERMINING SIGHT-LINE CALCULATIONS.
- 2) THE LINE OF SIGHT IS ESTABLISHED AT A CORNER PROPERTY AS FOLLOWS:
FROM A POINT ALONG A LINE THAT BISECTS AN INTERIOR ANGLE, SAID ANGLE IS BEING FORMED BY INTERSECTING THE FRONT AND SIDE SETBACK LINES, THE LINE OF SIGHT IS ESTABLISHED PERPENDICULAR TO SAID BISECTING LINE AND 3 FEET FROM THE ABOVE REFERENCED POINT. THE LINE OF SIGHT SHALL EXTEND TO INTERSECT THE FRONT AND SIDE PROPERTY LINES. HOWEVER, THE LENGTH OF THIS LINE SHALL BE A MINIMUM OF 45 FEET, MEASURED FROM A POINT OF INTERSECTION WITH THE SIDE PROPERTY LINE TO A POINT OF INTERSECTION WITH THE FRONT PROPERTY LINE. THE SIGHT DISTANCE REQUIREMENTS SHALL FURTHER COMPLY WITH THE PROVISIONS OF SECTION 12.12.120 OF THE MUNICIPAL CODE.
- 3) PER CHULA VISTA MUNICIPAL CODE SECTION 12.12.120, ALL FENCES, WALLS, HEDGES OR OTHER OBSTRUCTIONS TO VISION, THAT ARE LOCATED WITHIN THE SIGHT VISION TRIANGLE, SHALL BE LIMITED TO A MAXIMUM HEIGHT OF 3.0 FEET, MEASURED FROM EVERY POINT ALONG THE OUTER EDGE OF THE PAVED SURFACE OF THE ROADWAY.

REVISION	BY	APPROVED	DATE
ORIGINAL	CVM	C. SWANSON	11/02
REVISION	DPH	W. VALLE	11/17

CITY OF CHULA VISTA
ENGINEERING & CAPITAL PROJECTS
STANDARD DRAWING

SIGHT DISTANCE REQUIREMENTS FOR
STREETS 40' OR LESS

William S. Valle
WILLIAM S. VALLE 11/21/2017
CITY ENGINEER

RWY-05

TURN LANE REQUIREMENTS

MAINLINE STREET	INTERSECTING STREET	LEFT TURN LANE REQUIREMENTS	RIGHT TURN LANE REQUIREMENTS
CLASS II COLLECTOR	CLASS II COLLECTOR	SINGLE	NO
CLASS II COLLECTOR	CLASS I COLLECTOR	SINGLE	NO
CLASS II COLLECTOR	MAJOR	SINGLE	NO
CLASS II COLLECTOR	PRIME	SINGLE	NO
CLASS I COLLECTOR	CLASS II COLLECTOR	SINGLE	NO
CLASS I COLLECTOR	CLASS I COLLECTOR	SINGLE	NO
CLASS I COLLECTOR	MAJOR	SINGLE	NO
CLASS I COLLECTOR	PRIME	SINGLE	NO
MAJOR	CLASS II COLLECTOR	SINGLE	NO
MAJOR	CLASS I COLLECTOR	SINGLE	NO
MAJOR	MAJOR	DOUBLE	YES
MAJOR	PRIME	DOUBLE	YES
PRIME	CLASS II COLLECTOR	SINGLE	NO
PRIME	CLASS I COLLECTOR	SINGLE	NO
PRIME	MAJOR	DOUBLE	YES
PRIME	PRIME	DOUBLE	YES

ADDITIONAL REQUIREMENTS FOR RIGHT TURN LANE

PEAK HOUR RIGHT TURN VOLUMES	RIGHT TURN GEOMETRICS	TURN POCKET LENGTHS
0-299		NOT APPLICABLE
300-399		$285' = ((399/35) \times 25')$
400-475		200'
476-600		200'**
GREATER THAN 600		$((RT. \text{ TURN VOLS.}/2)/35) \times 25''$

KEY: = TRAVEL LANE = BIKE LANE

** ADDITIONAL 12' OF RIGHT OF WAY REQUIRED OVER ESTABLISHED CITY OF CHULA VISTA PRIME ARTERIAL STANDARDS AND A 120' REVERSE CURVE IS NEEDED FOR THE RIGHT TURN POCKET.

SHEET 1 OF 2

REVISION	BY	APPROVED	DATE	CITY OF CHULA VISTA ENGINEERING & CAPITAL PROJECTS STANDARD DRAWING	 WILLIAM S. VALLE 11/21/2017 CITY ENGINEER
ORIGINAL			2/90		
REVISION	CVM	C. SWANSON	11/02		
REVISION	DPH	W. VALLE	11/17		
				TURN LANE REQUIREMENTS	RWY-06

TURN LANE REQUIREMENTS

MAINLINE STREET	INTERSECTING STREET	LEFT TURN LANE REQUIREMENTS	RIGHT TURN LANE REQUIREMENTS
SECONDARY VILLAGE ENTRY/ CLASS II COLLECTOR	CLASS II COLLECTOR/ SECONDARY VILLAGE ENTRY	SINGLE	NO
SECONDARY VILLAGE ENTRY/ CLASS II COLLECTOR	CLASS I COLLECTOR/ VILLAGE ENTRY	SINGLE	NO
SECONDARY VILLAGE ENTRY/ CLASS II COLLECTOR	MAJOR	SINGLE	NO
SECONDARY VILLAGE ENTRY/ CLASS II COLLECTOR	PRIME	SINGLE	NO
VILLAGE ENTRY/ CLASS I COLLECTOR	CLASS II COLLECTOR/ SECONDARY VILLAGE ENTRY	SINGLE	
VILLAGE ENTRY/ CLASS I COLLECTOR	CLASS I COLLECTOR/ SECONDARY VILLAGE ENTRY	SINGLE	NO
VILLAGE ENTRY/ CLASS I COLLECTOR	MAJOR	SINGLE	NO
VILLAGE ENTRY/ CLASS I COLLECTOR	PRIME	SINGLE	NO
MAJOR	CLASS II COLLECTOR/ SECONDARY VILLAGE ENTRY	SINGLE	NO
MAJOR	CLASS I COLLECTOR/ VILLAGE ENTRY	SINGLE	NO
MAJOR	MAJOR	DOUBLE	YES
MAJOR	PRIME	DOUBLE	YES
PRIME	CLASS II COLLECTOR/ SECONDARY VILLAGE ENTRY	SINGLE	NO
PRIME	CLASS I COLLECTOR/ VILLAGE ENTRY	SINGLE	NO
PRIME	MAJOR	DOUBLE	YES
PRIME	PRIME	DOUBLE	YES

SEE RWY-06 FOR ADDITIONAL REQUIREMENTS FOR RIGHT TURN LANE.

SHEET 2 OF 2

REVISION	BY	APPROVED	DATE	CITY OF CHULA VISTA ENGINEERING & CAPITAL PROJECTS STANDARD DRAWING OTAY RANCH – TURN LANE REQUIREMENTS	 WILLIAM S. VALLE CITY ENGINEER
ORIGINAL	CVM		2/00		
REVISION	CVM	C. SWANSON	11/02		
REVISION	DPH	W. VALLE	11/17		
					RWY-06

CURVE DATA
 $\Delta 4 = \Delta 1 + \Delta 2 + \Delta 3$
 F/C R=60'(MIN.)
 P/L R=60'(MIN.)+P

CURVE DATA
 F/C R=50'(MIN.)
 P/L R=50'(MIN.)-P

CURVE DATA
 F/C R=50'(MIN.)
 P/L R=50'(MIN.)-P

CURVE DATA
 $\Delta 1$ VARIABLE
 C/L R=25'+R/W/2
 F/C R=25'+P(MIN.)
 P/L R=25'(MIN.)

NOTE: THIS KNUCKLE DETAIL IS REQUIRED WHERE THE STREET TERMINATES IN A CUL-DE-SAC WHERE SAID CUL-DE-SAC IS MORE THAN 400 FEET DISTANT. (MEASURED FROM C/L OF STREET TO CENTER OF CUL-DE-SAC.)

NOTE: CROWN LINE & POINTS REQUIRING ELEVATIONS, SHOWN IN TYPE II PLAN, ALSO PERTAIN TO TYPE I PLAN BELOW.

TYPE II
 NO SCALE

CURVE DATA
 $\Delta 4 = \Delta 1 + \Delta 2 + \Delta 3$
 F/C R=R/W+10'
 P/L R=R/W+10'

CURVE DATA
 F/C R=50'(MIN.)
 P/L R=50'(MIN.)-P

CURVE DATA
 $\Delta 1$ VARIABLE
 C/L R=25'+R/W/2
 F/C R=25'+P(MIN.)
 P/L R=25'(MIN.)

NOTE: THIS KNUCKLE DETAIL IS REQUIRED WHERE THE STREET PATTERN FORMS A CONTINUOUS LOOP, OR WHERE SAID STREET TERMINATES IN A CUL-DE-SAC LESS THAN 400 FEET FROM KNUCKLE. (MEASURED FROM C/L OF STREET TO CENTER OF CUL-DE-SAC.)

CURVE DATA
 F/C R=50'(MIN.)
 P/L R=50'(MIN.)-P

GENERAL NOTES:

1. USE NORMAL SECTION FROM INNER CURB TO C/L.
2. FROM CROWN LINE TO OUTER CURB, THE MAXIMUM SLOPE IS 1/2" PER FOOT.
3. SUPERELEVATION PERCENTAGES SHOWN ARE STRAIGHT FROM C/L TO CROWN.
4. o = INDICATES ELEVATIONS REQUIRED.
5. WHEN STREETS HAVE TILT-TYPE SECTION, THE CROWN WILL NOT NECESSARILY TERMINATE ON C/L AT ANGLE POINT OF CURB.
6. A SPECIFIC DEPARTURE FROM THIS PLAN MAY BE OBTAINED BY SPECIAL PERMISSION.
7. OFFSET CROWN DESIGN IS TYPICAL FOR BOTH TYPES OF KNUCKLES SHOWN.

LEGEND:

P=F/C TO P/L DISTANCE
 C/L=CENTERLINE
 F/C=FACE OF CURB
 P/L=PROPERTY LINE
 R/W=RIGHT OF WAY

TYPE I
 NO SCALE

REVISION	BY	APPROVED	DATE
ORIGINAL			10/67
REVISION	CM	C. SWANSON	11/02
REVISION	DPH	W. VALLE	11/17

CITY OF CHULA VISTA
 ENGINEERING & CAPITAL PROJECTS
 STANDARD DRAWING

William S. Valle
 WILLIAM S. VALLE 11/21/2017
 CITY ENGINEER

KNUCKLES TYPE I AND TYPE II

RWY-07

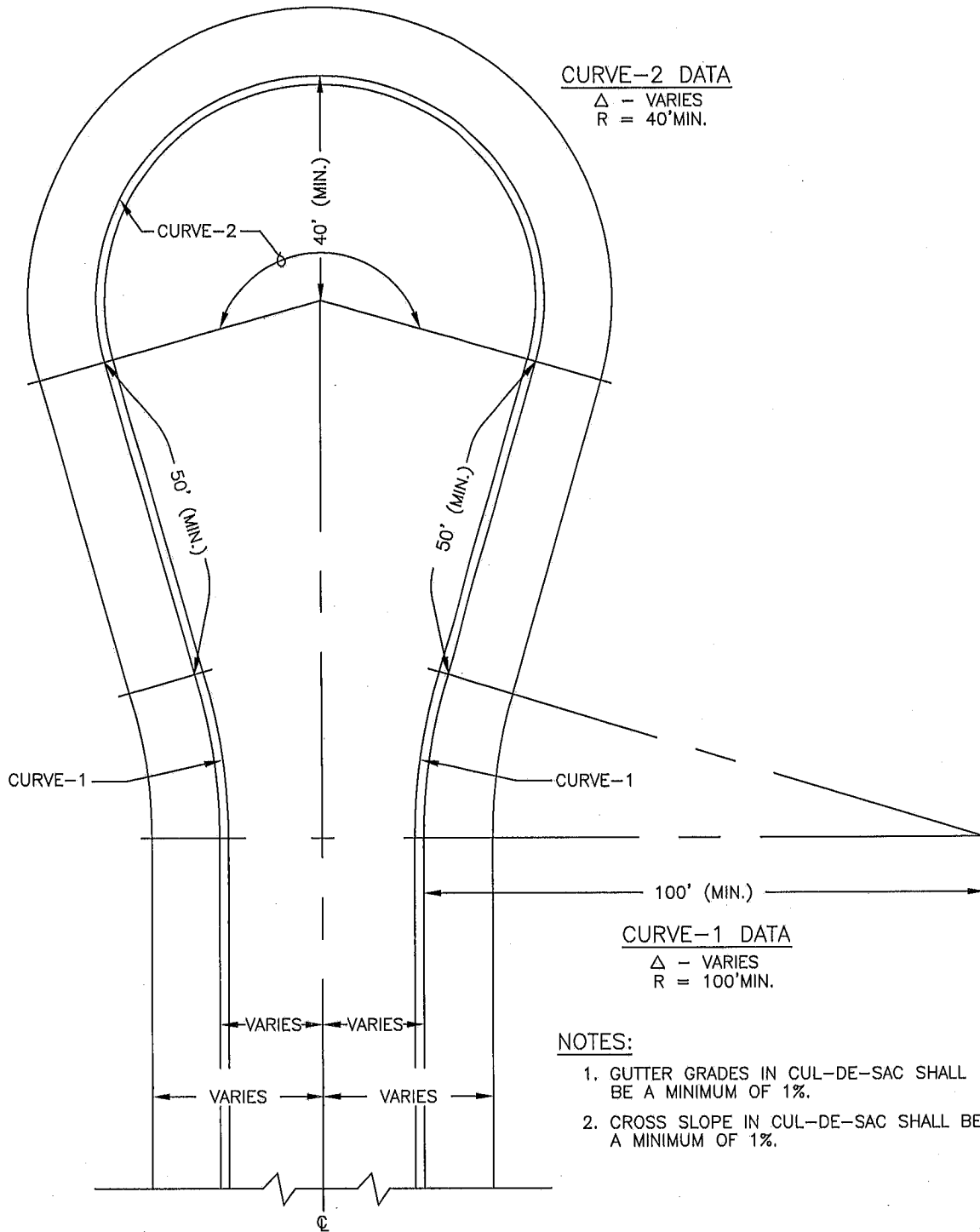

CURVE-2 DATA

Δ - VARIES
R = 40' MIN.

CURVE-1 DATA

Δ - VARIES
R = 100' MIN.

NOTES:

1. GUTTER GRADES IN CUL-DE-SAC SHALL BE A MINIMUM OF 1%.
2. CROSS SLOPE IN CUL-DE-SAC SHALL BE A MINIMUM OF 1%.

PLAN
NO SCALE

REVISION	BY	APPROVED	DATE
ORIGINAL			10/67
REVISION	CVM	C. SWANSON	11/02
REVISION	DPH	W. VALLE	11/17

CITY OF CHULA VISTA
ENGINEERING & CAPITAL PROJECTS
STANDARD DRAWING

William S. Valle
WILLIAM S. VALLE 11/21/2017
CITY ENGINEER

CUL-DE-SAC

RWY-08

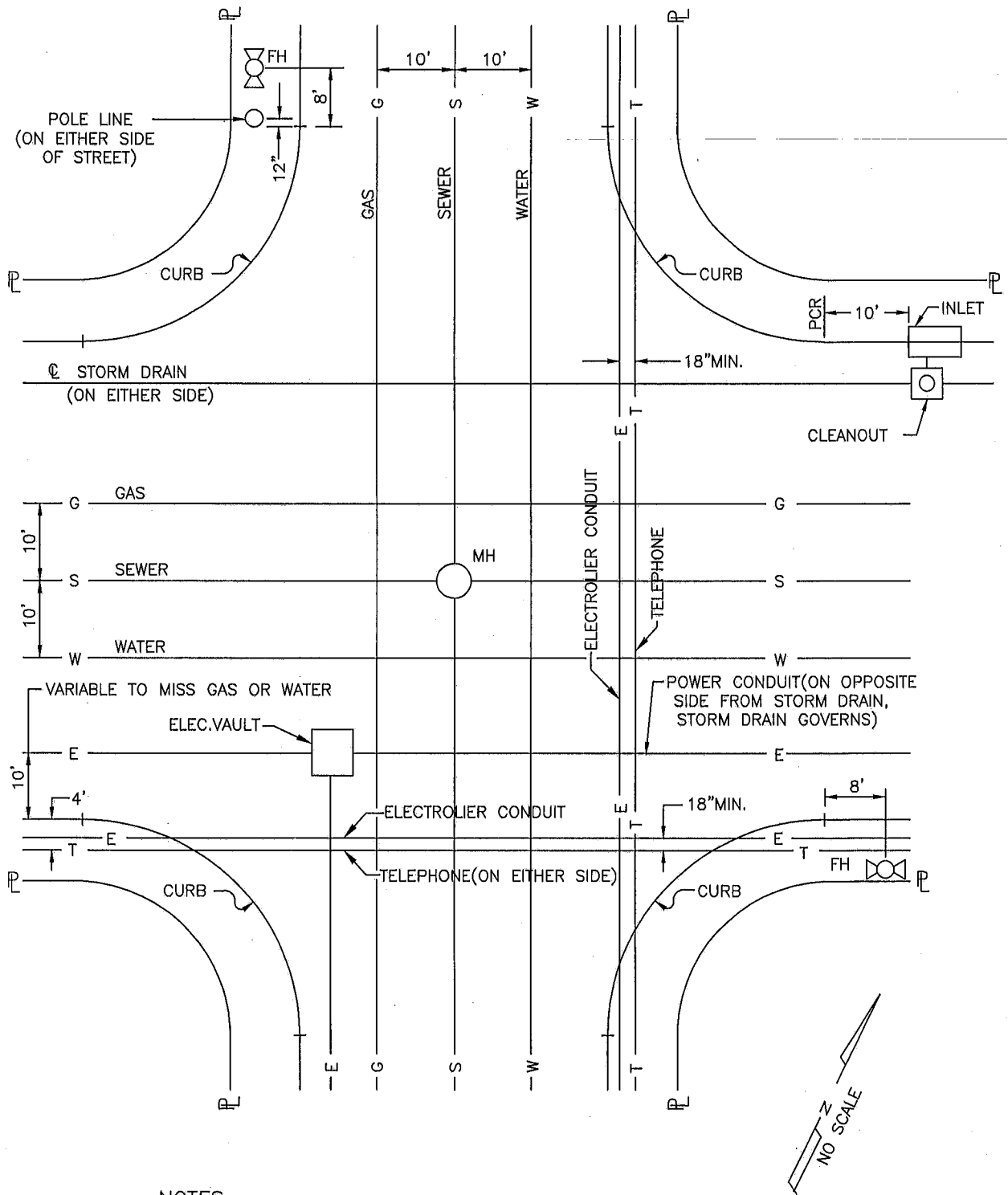

NOTES:

THIS STANDARD IS A GUIDE ONLY. DIMENSIONS SHOWN ARE DESIREABLE BUT DO NOT GOVERN. IF SUCH LOCATIONS ARE IMPRACTICAL, PERMISSION FOR VARIANCE MAY BE APPROVED BY THE CITY ENGINEER.



REVISION	BY	APPROVED	DATE
ORIGINAL			7/75
REVISION	CVM	C. SWANSON	11/02
REVISION	DPH	W. VALLE	11/17

CITY OF CHULA VISTA
 ENGINEERING & CAPITAL PROJECTS
 STANDARD DRAWING

LOCATION OF UNDERGROUND
 UTILITIES IN STREET

William S. Valle
 WILLIAM S. VALLE 11/21/2017
 CITY ENGINEER

RWY-09

SEWER

(SWR)



RATIO OF PEAK TO AVERAGE SEWAGE FLOW VS. MAGNITUDE OF TRIBUTARY POPULATION

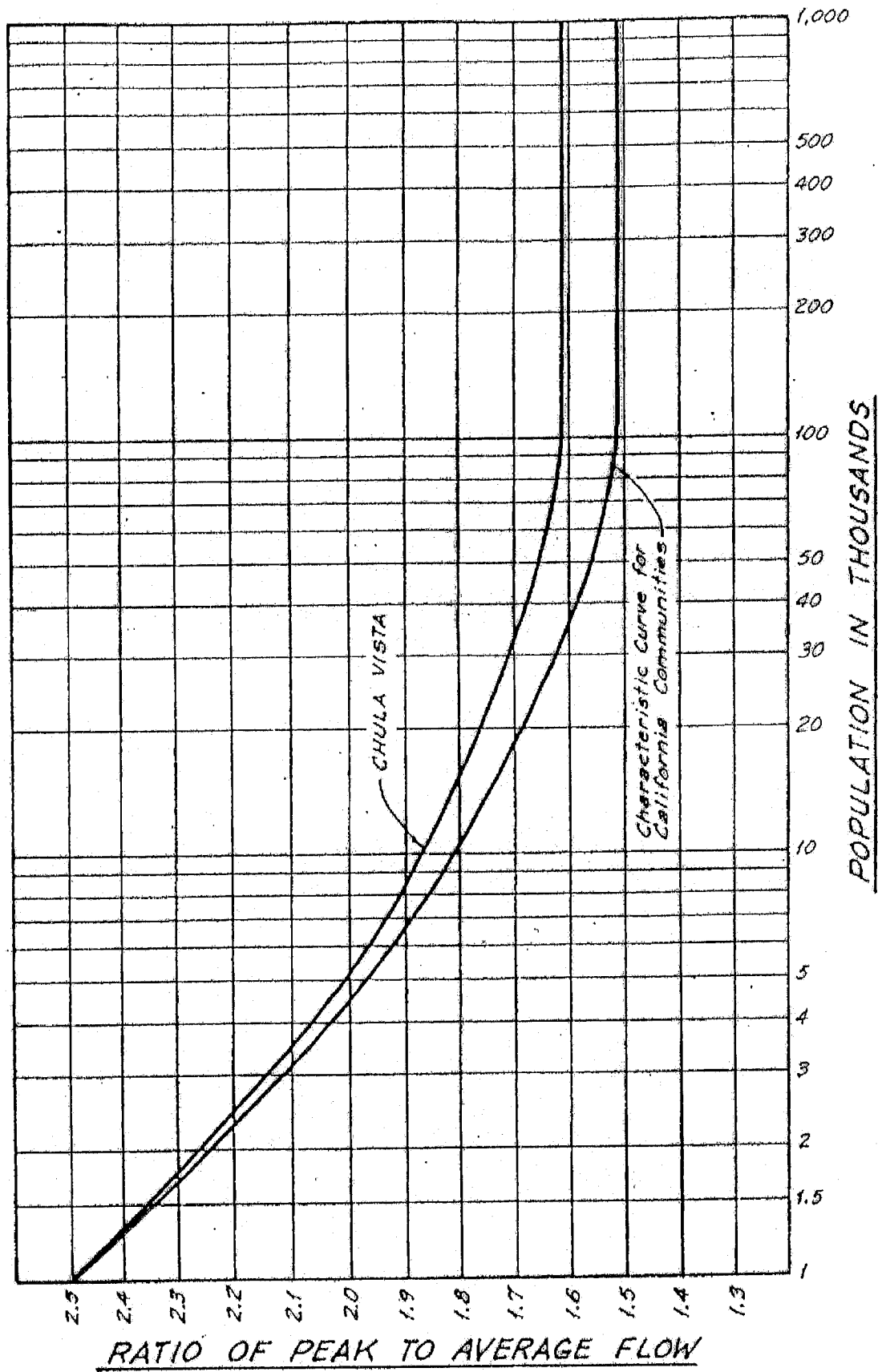

REVISION	BY	APPROVED	DATE
ORIGINAL	JWH		10/72
		C. SWANSON	11/02
REVISION	DPH	W. VALLE	11/17

CITY OF CHULA VISTA
ENGINEERING & CAPITAL PROJECTS
STANDARD DRAWING

PEAK TO AVERAGE SEWER FLOW

William S. Valle
WILLIAM S. VALLE 11/21/2017
CITY ENGINEER

SWR-01

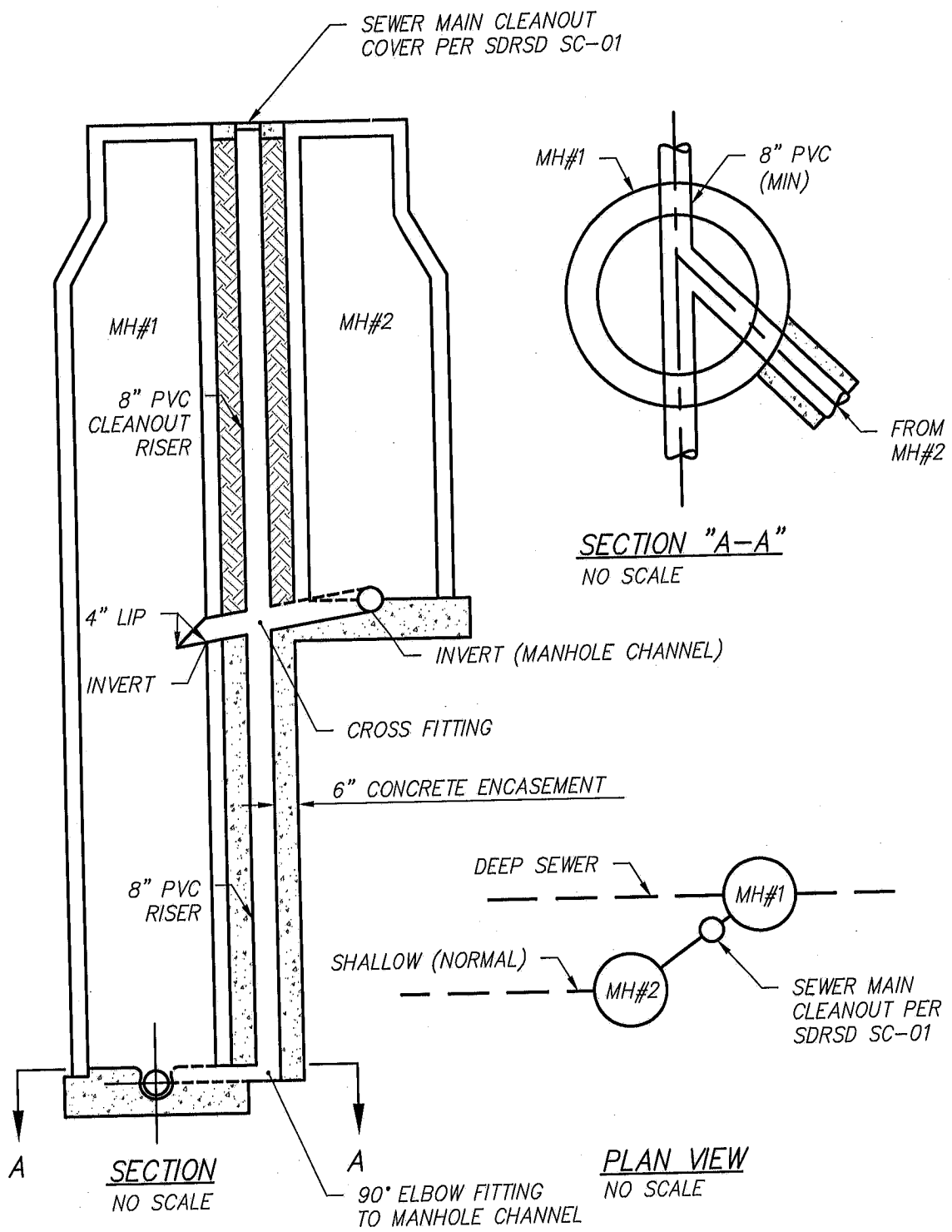

NOTE: OTHER OPTIONS AVAILABLE ON A CASE-BY-CASE BASIS.

REVISION	BY	APPROVED	DATE
ORIGINAL			2/90
REVISION	CVM	C. SWANSON	11/02
REVISION	DPH	W. VALLE	11/17

CITY OF CHULA VISTA
 ENGINEERING & CAPITAL PROJECTS
 STANDARD DRAWING

DEEP SEWER CONNECTION

William S. Valle
 WILLIAM S. VALLE 11/21/2017
 CITY ENGINEER
 SWR-02

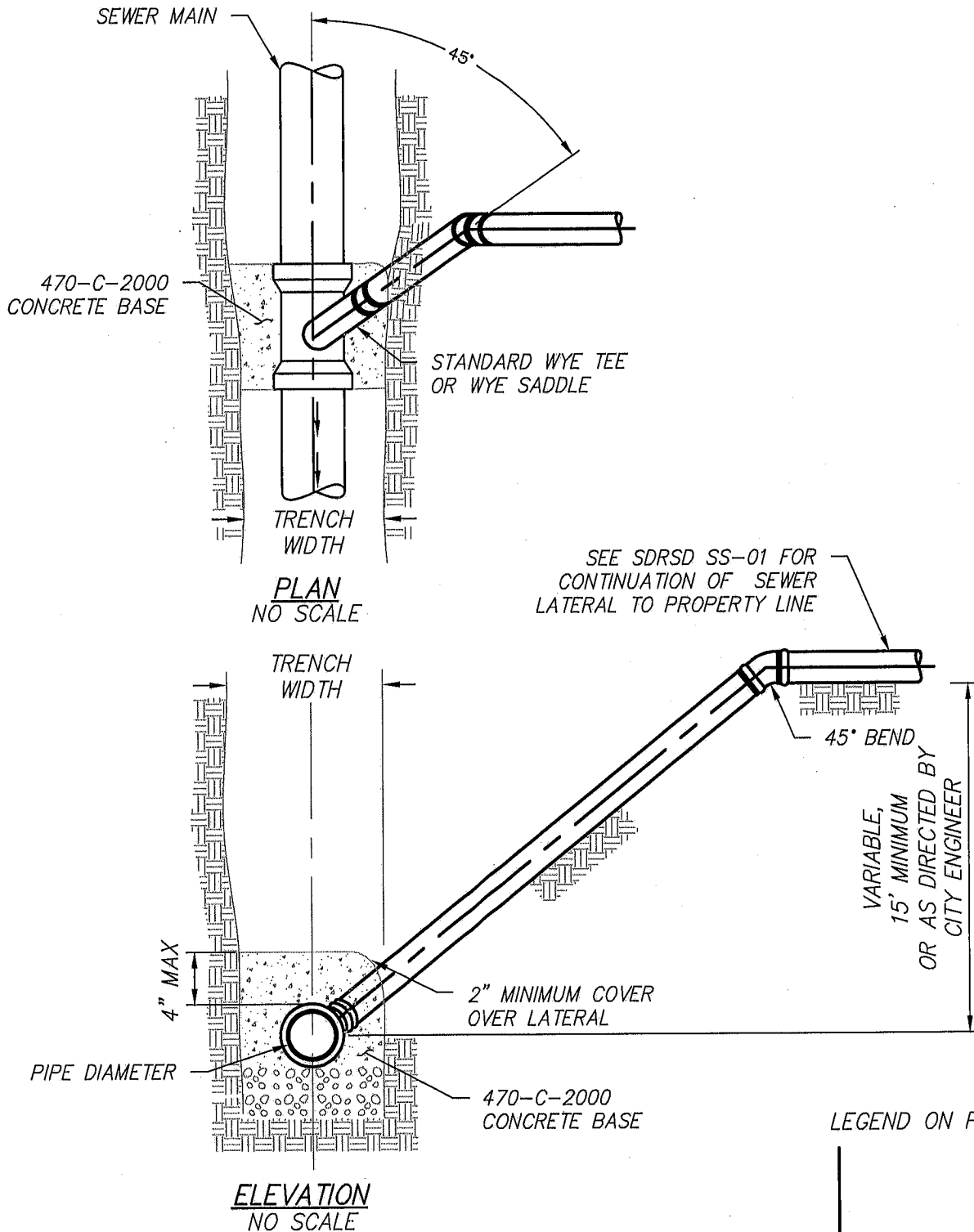

NOTES:

1. ALL JOINTS ON SEWER LATERAL PIPE SHALL BE COMPRESSION TYPE OR APPROVED SOLVENT WELD CONNECTION.
2. DEEP CUT HOUSE CONNECTION FOR SEWER LATERAL MAY BE USED ONLY UPON APPROVAL BY THE CITY ENGINEER.

LEGEND ON PLANS

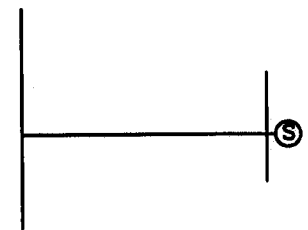

REVISION	BY	APPROVED	DATE	CITY OF CHULA VISTA ENGINEERING & CAPITAL PROJECTS STANDARD DRAWING	 WILLIAM S. VALLE CITY ENGINEER
ORIGINAL		C. SWANSON	3/94 11/02		
REVISION	DPH	W. VALLE	11/17	DEEP CUT HOUSE CONNECTION SEWER LATERAL	11/21/2017 CITY ENGINEER
					SWR-03

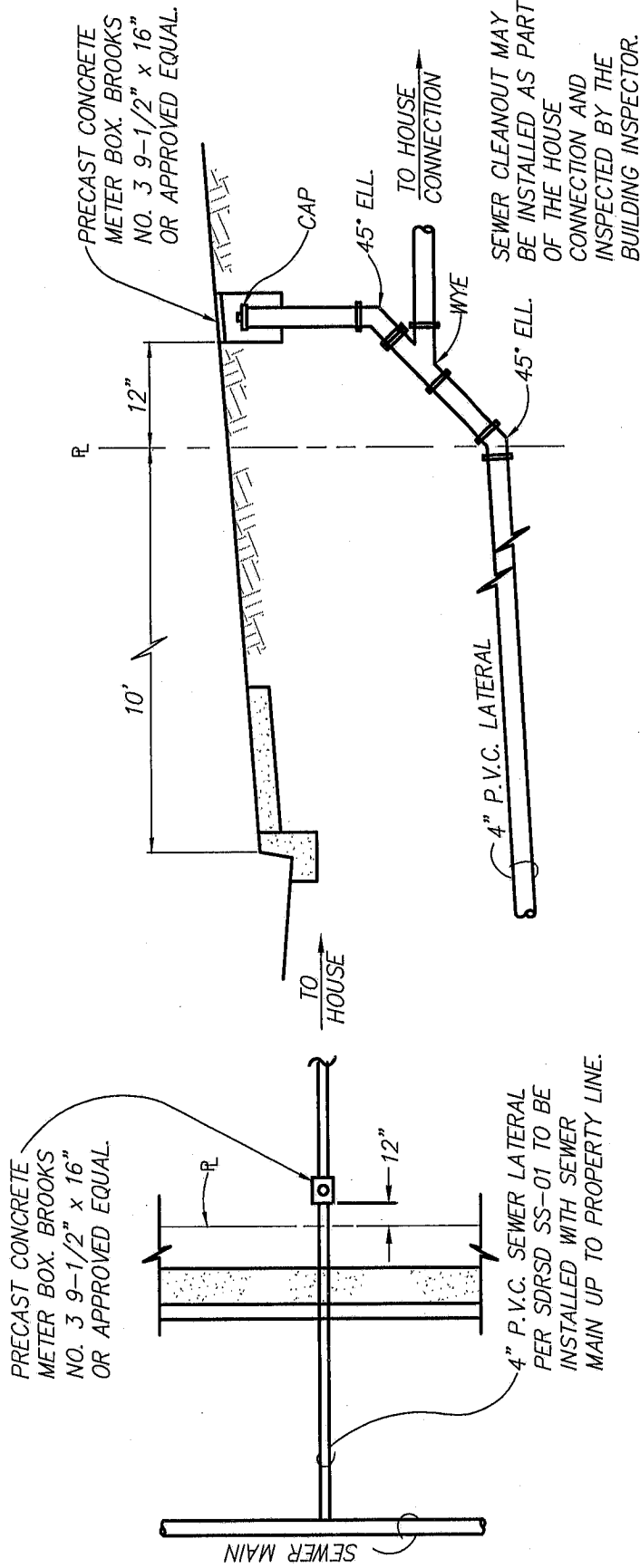

PROFILE
NO SCALE

PLAN VIEW
NO SCALE

DETAIL ~ SEWER LATERAL IN LANDSCAPED AREAS

NOTES:

1. FOR DETAILS NOT SHOWN SEE SDRSD NO. SS-01 AND SS-02
2. BACKFLOW PREVENTION DEVICES AND BUILDING CLEANOUT SHALL BE LOCATED WITHIN THE BUILDING DRAIN PER UPC REQUIREMENTS.
3. STAMP "S" ON FACE OF CURB.
4. ALL LATERALS ARE PRIVATE PER COUNCIL POLICY 570-01

REVISION	BY	APPROVED	DATE
ORIGINAL			10/96
REVISION	CVM	C. SWANSON	11/02
REVISION	DPH	W. VALLE	11/17

CITY OF CHULA VISTA
ENGINEERING & CAPITAL PROJECTS
STANDARD DRAWING
SEWER LATERAL IN LANDSCAPED
AREAS

William S. Valle
WILLIAM S. VALLE 11/21/2017
CITY ENGINEER

SWR-04

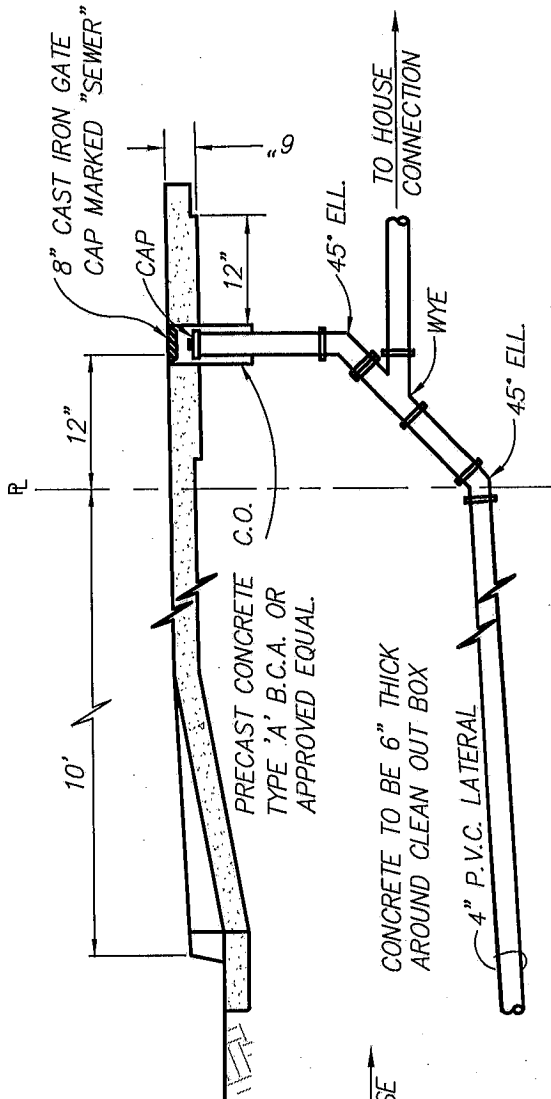

SEWER CLEANOUT MAY BE INSTALLED AS PART OF THE HOUSE CONNECTION AND INSPECTED BY THE BUILDING INSPECTOR.

PROFILE
NO SCALE

FOR DETAILS NOT SHOWN SEE SDRSD SS-01 AND SS-02

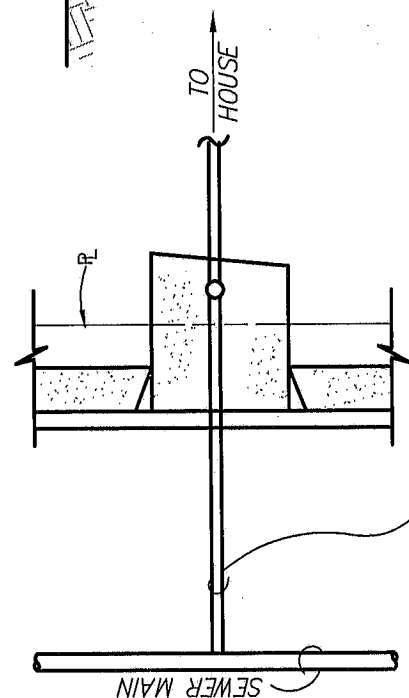

4" P.V.C. SEWER LATERAL PER SDRSD SS-01 TO BE INSTALLED WITH SEWER MAIN UP TO PROPERTY LINE.

PLAN VIEW
NO SCALE

DETAIL ~ SEWER LATERAL IN P.C.C. DRIVEWAY

NOTE: BACKFLOW PREVENTION DEVICES AND BUILDING CLEANOUT SHALL BE LOCATED WITHIN THE BUILDING DRAIN PER UPC REQUIREMENTS. STAMP "S" ON FACE OF CURB.

REVISION	BY	APPROVED	DATE
ORIGINAL			10/96
REVISION	CM	C. SWANSON	11/02
REVISION	DPH	W. VALLE	11/17

CITY OF CHULA VISTA
ENGINEERING & CAPITAL PROJECTS
STANDARD DRAWING
SEWER LATERAL IN PCC DRIVEWAY

William S. Valle
WILLIAM S. VALLE 11/21/2017
CITY ENGINEER
SWR-05

PRECAST CONCRETE METER BOX. BROOKS NO. 3 9-1/2" x 16" OR APPROVED EQUAL.

PRECAST CONCRETE METER BOX. BROOKS NO. 3 9-1/2" x 16" OR APPROVED EQUAL.

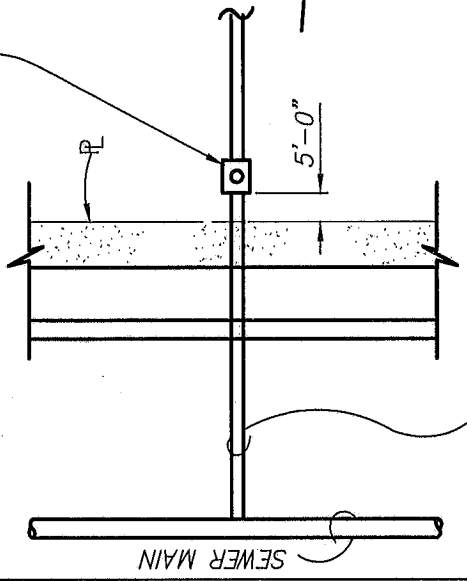

4" P.V.C. SEWER LATERAL PER SDRSD SS-01 TO BE INSTALLED WITH SEWER MAIN UP TO PROPERTY LINE.

PLAN VIEW
NO SCALE

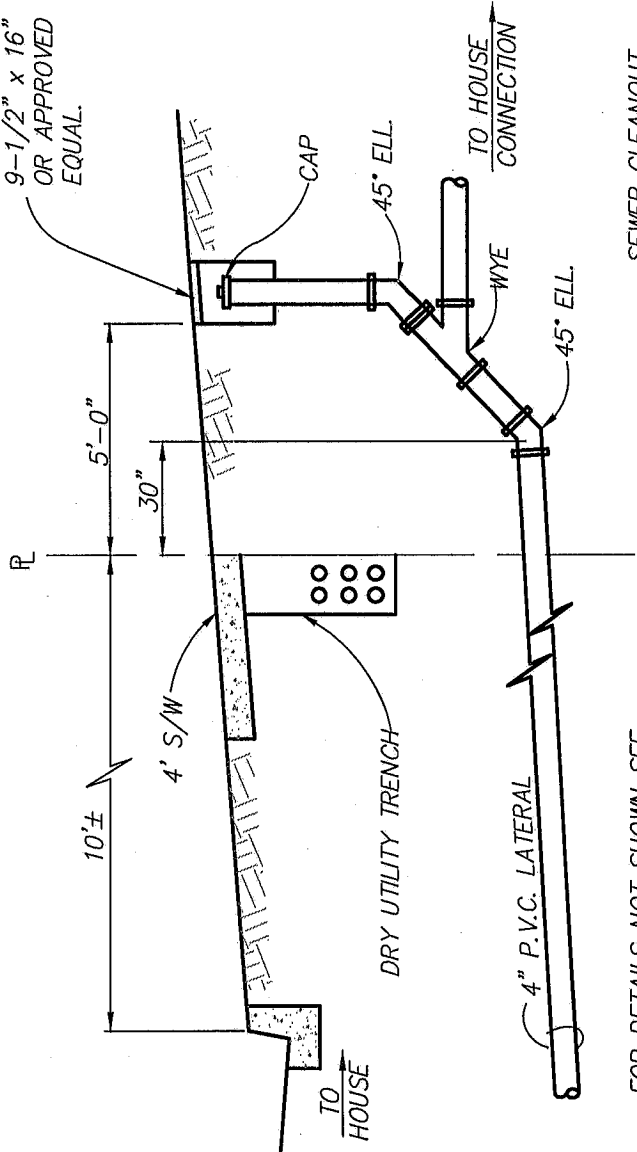

FOR DETAILS NOT SHOWN SEE SDRSD SS-01 AND SS-02

PROFILE
NO SCALE

SEWER CLEANOUT MAY BE INSTALLED AS PART OF THE HOUSE CONNECTION AND INSPECTED BY THE BUILDING INSPECTOR.

DETAIL ~ SEWER LATERAL IN LANDSCAPED AREAS
(SIDEWALK AND DRY UTILITY TRENCH AT PROPERTY LINE)

NOTE: BACKFLOW PREVENTION DEVICES AND BUILDING CLEANOUT SHALL BE LOCATED WITHIN THE BUILDING DRAIN PER UPC REQUIREMENTS OR PER CITY PLANNING AND BUILDING REQUIREMENTS STAMP "S" ON FACE OF CURB.

REVISION	BY	APPROVED	DATE
ORIGINAL			7/90
REVISION	CM	C. SWANSON	11/02
REVISION	DPH	W. VALLE	11/17

CITY OF CHULA VISTA
ENGINEERING & CAPITAL PROJECTS
STANDARD DRAWING
SEWER LATERAL IN LANDSCAPE SW
& DRY UTILITIES IN R.O.W.

William S. Valle
WILLIAM S. VALLE 11/21/2017
CITY ENGINEER
SWR-06

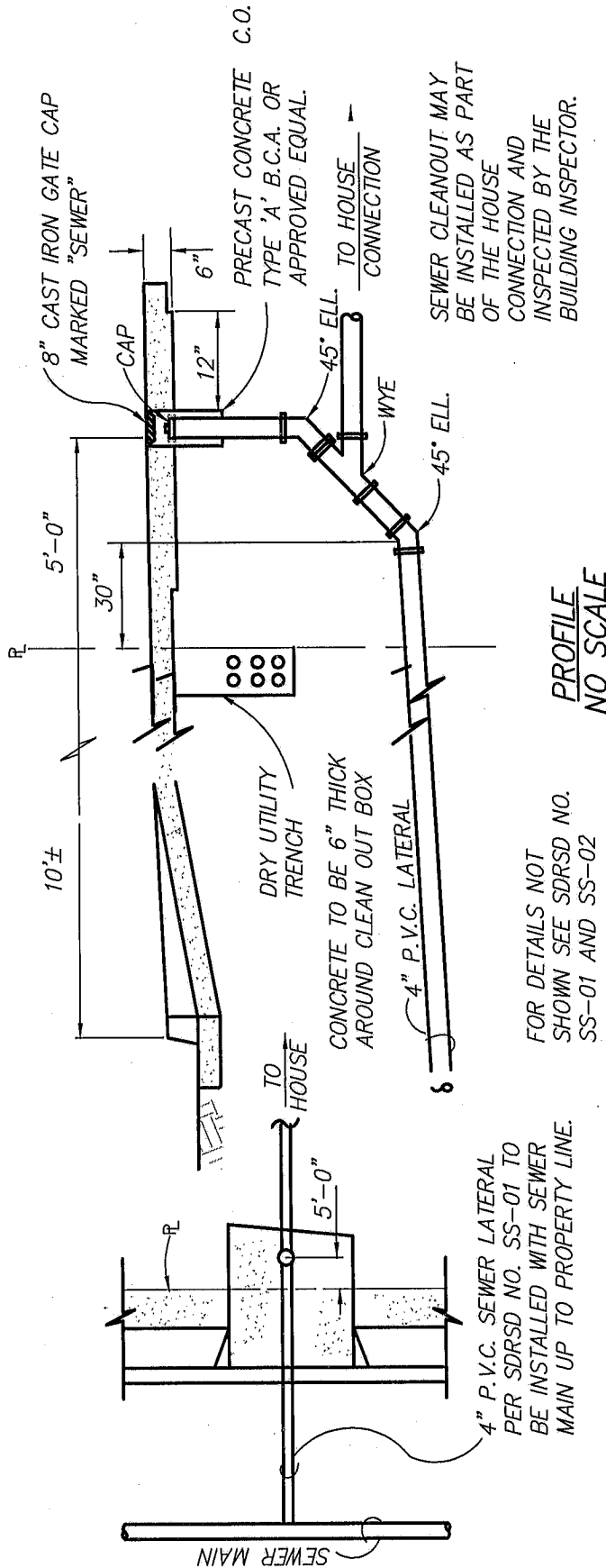

PLAN VIEW
NO SCALE

FOR DETAILS NOT SHOWN SEE SDRSD NO. SS-01 AND SS-02

PROFILE
NO SCALE

SEWER CLEANOUT MAY BE INSTALLED AS PART OF THE HOUSE CONNECTION AND INSPECTED BY THE BUILDING INSPECTOR.

DETAIL ~ PRIVATE SEWER LATERAL IN P.C.C. DRIVEWAY (SIDEWALK AND DRY UTILITY TRENCH AT PROPERTY LINE)

NOTE: BACKFLOW PREVENTION DEVICES AND BUILDING CLEANOUT SHALL BE LOCATED WITHIN THE BUILDING DRAIN PER UPC REQUIREMENTS OR PER CITY PLANNING AND BUILDING REQUIREMENTS STAMP "S" ON FACE OF CURB.

REVISION	BY	APPROVED	DATE
ORIGINAL			7/99
REVISION	CVM	C. SWANSON	11/02
REVISION	DPH	W. VALLE	11/17

CITY OF CHULA VISTA
ENGINEERING & CAPITAL PROJECTS
STANDARD DRAWING
SEWER LATERAL IN PCC DWY - SW
& DRY UTILITIES IN R.O.W.

William S. Valle
WILLIAM S. VALLE 11/21/2017
CITY ENGINEER
SWR-07

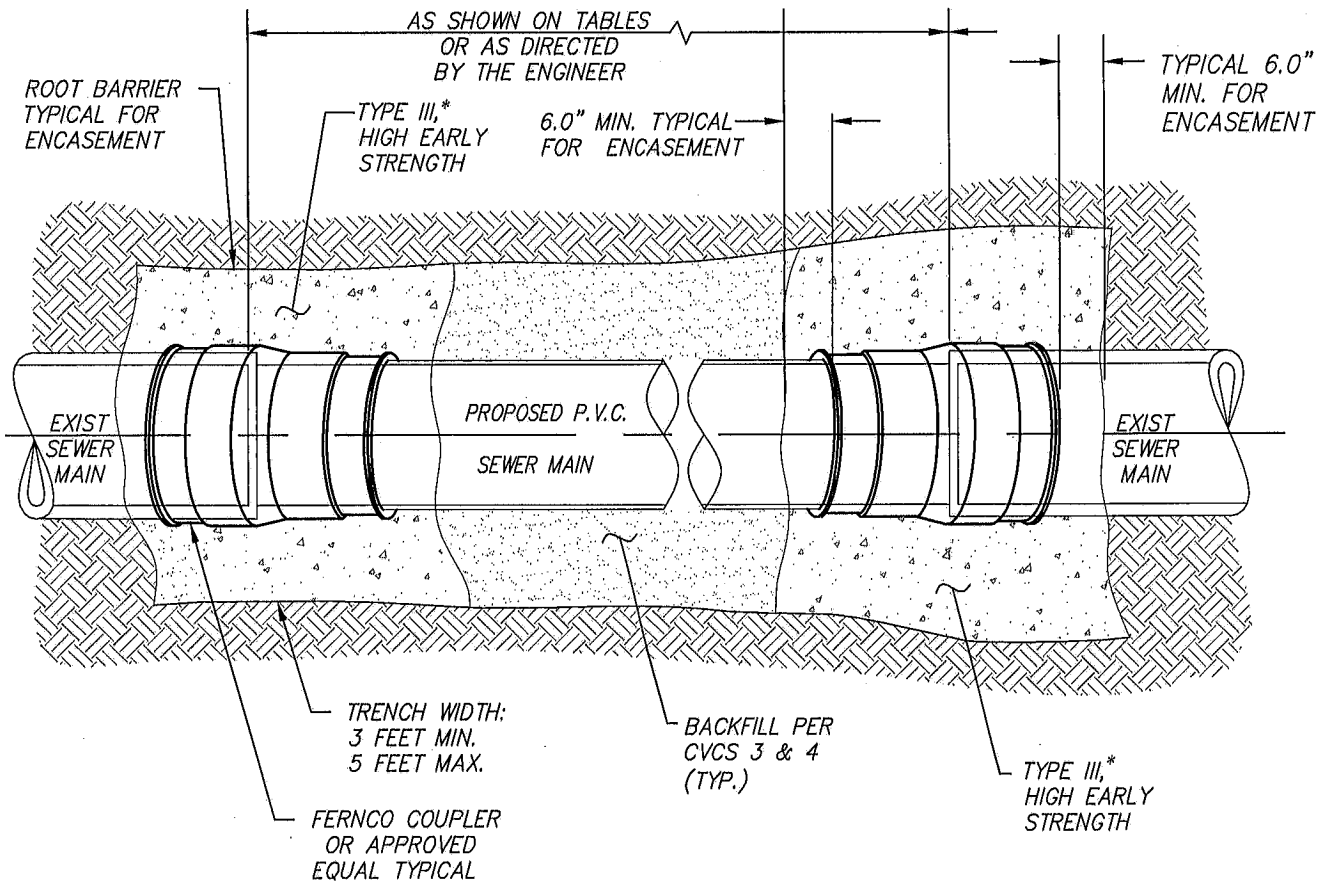

* ENCASEMENT:
REACH MIN. STRENGTH OF
2000 PSI WITHIN 24 HOURS.

REVISION	BY	APPROVED	DATE
ORIGINAL	DPH	W. VALLE	11/17

CITY OF CHULA VISTA
ENGINEERING & CAPITAL PROJECTS
STANDARD DRAWING

SEWER MAIN REPAIR DETAILS

William S. Valle
WILLIAM S. VALLE 11/21/2017
CITY ENGINEER
SWR-08

TRAFFIC

(TRF)



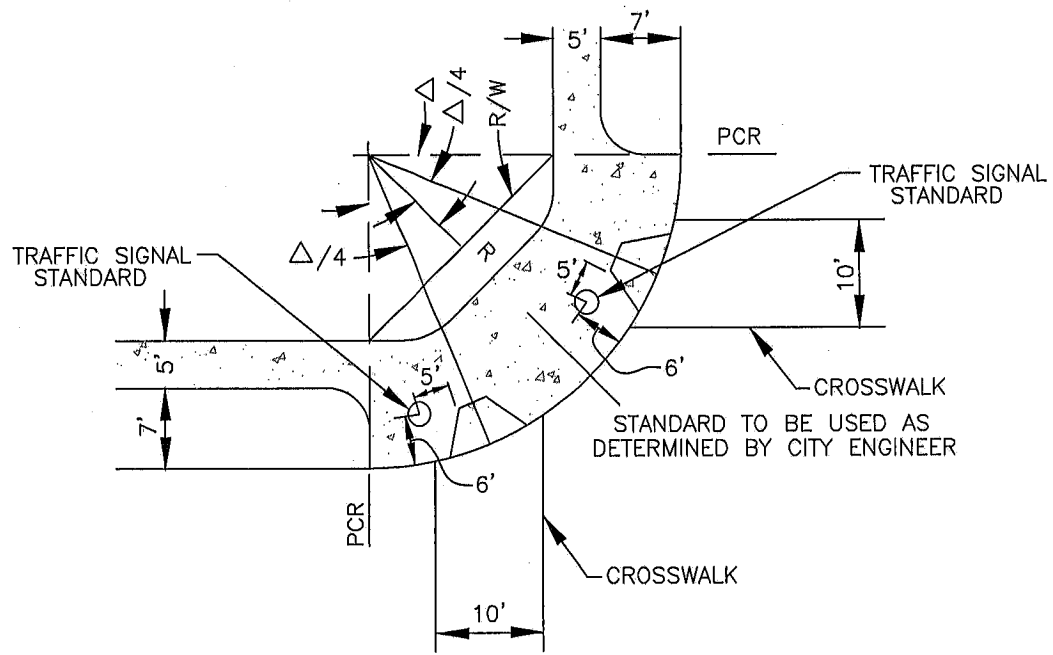
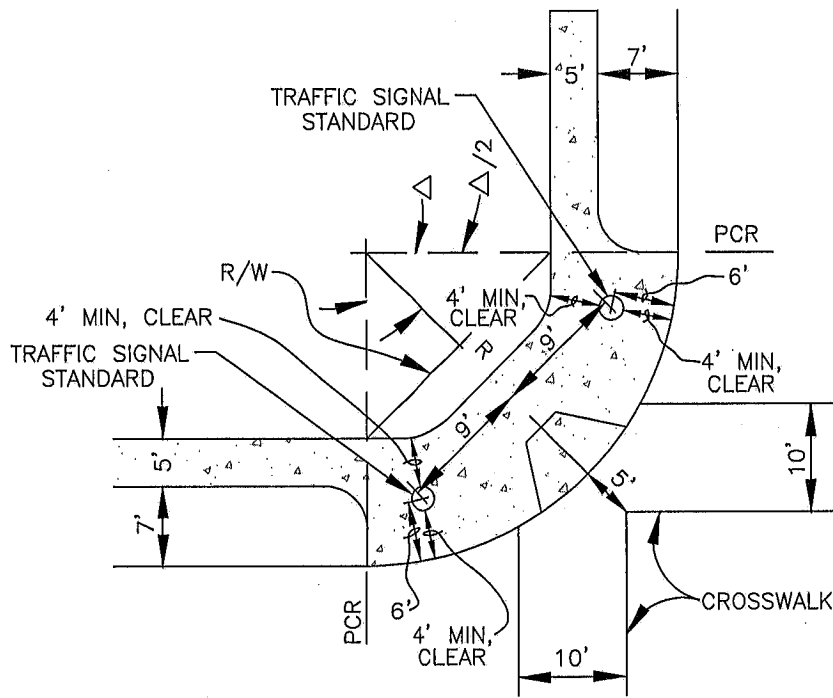

NOTES:

FINAL DETERMINATION OF TRAFFIC SIGNAL STANDARD LOCATION SHALL BE MADE BY THE CITY'S TRAFFIC ENGINEERING SECTION PRIOR TO INSTALLATION.

REVISION	BY	APPROVED	DATE
ORIGINAL			2/90
REVISION	CVM	C. SWANSON	11/02
REVISION	DPH	W. VALLE	11/17

CITY OF CHULA VISTA
ENGINEERING & CAPITAL PROJECTS
STANDARD DRAWING

TRAFFIC SIGNAL STANDARD
LOCATIONS

William S. Valle
WILLIAM S. VALLE 11/21/2017
CITY ENGINEER

TRF-01

FOR PARKWAYS LESS THAN 6' WIDE, ALL TRAFFIC SIGNS SHALL BE PLACED 6" INTO THE STREET SIDE OF THE SIDEWALK.

FOR PARKWAYS LESS THAN 6' WIDE, SIGN POSTS FOR STOP SIGN AND/OR STREET NAME SIGN SHALL BE PLACED 6" INTO THE STREET SIDE OF THE SIDEWALK AT PCR.

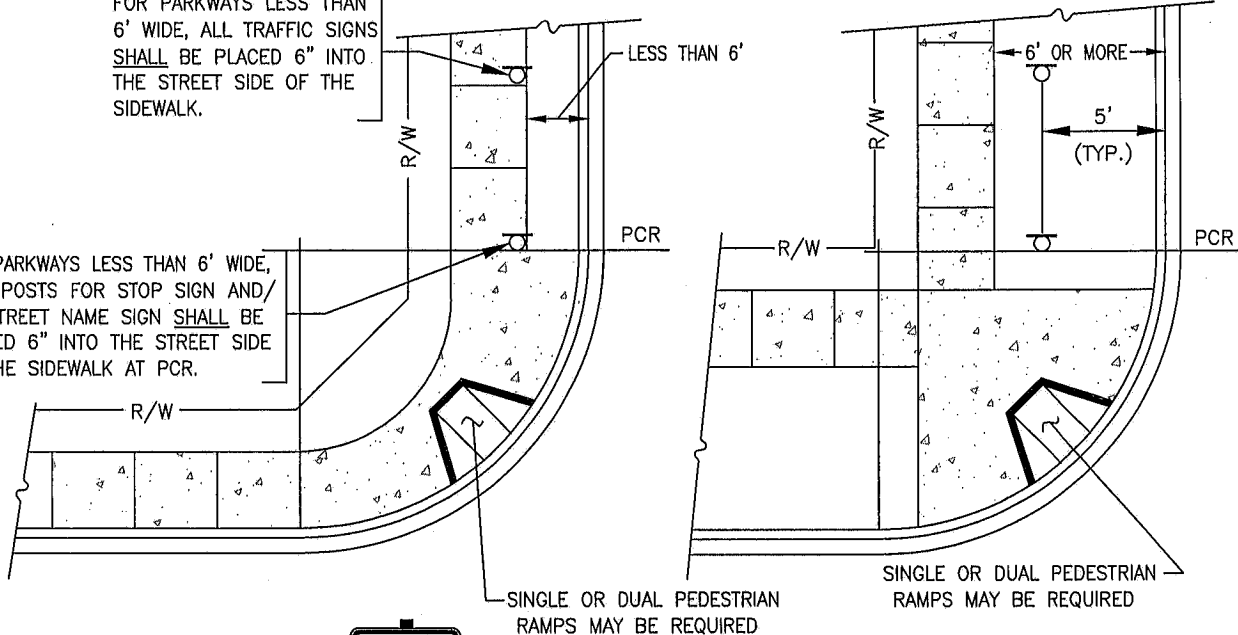

ALL TRAFFIC SIGNS OTHER THAN STOP SIGNS AND/OR STREET NAME SIGNS MAY BE INSTALLED EITHER ON 2" ID SCHEDULE 40 GALVANIZED STEEL POSTS OR ON TEL-SPAR POSTS PER TRF-10, LOCATED PER TRF-02.

STOP SIGNS AND/OR STREET NAME SIGNS SHALL BE INSTALLED ON 2" ID SCHEDULE 40 GALVANIZED STEEL PIPE, 12' STD. LENGTH, 2-3/8" OD FOR STREET NAME SIGN BRACKETS PER TRF-07 AND TRF-07.

STOP SIGN, 30" STANDARD, INSTALLATION, SEE DETAIL "A"

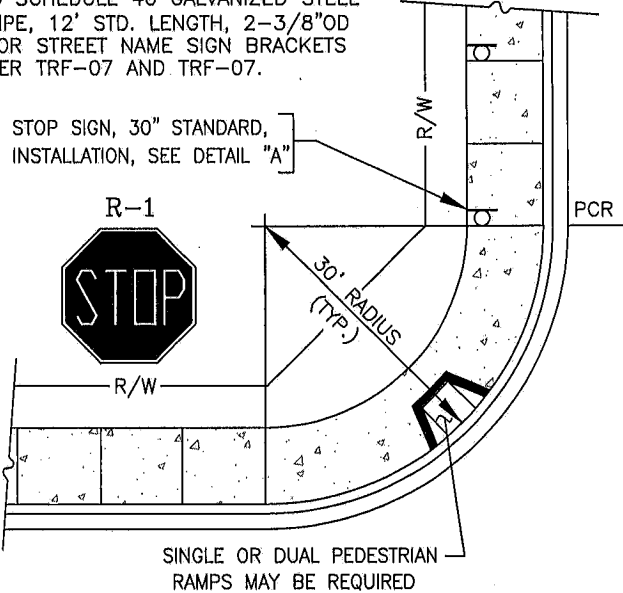
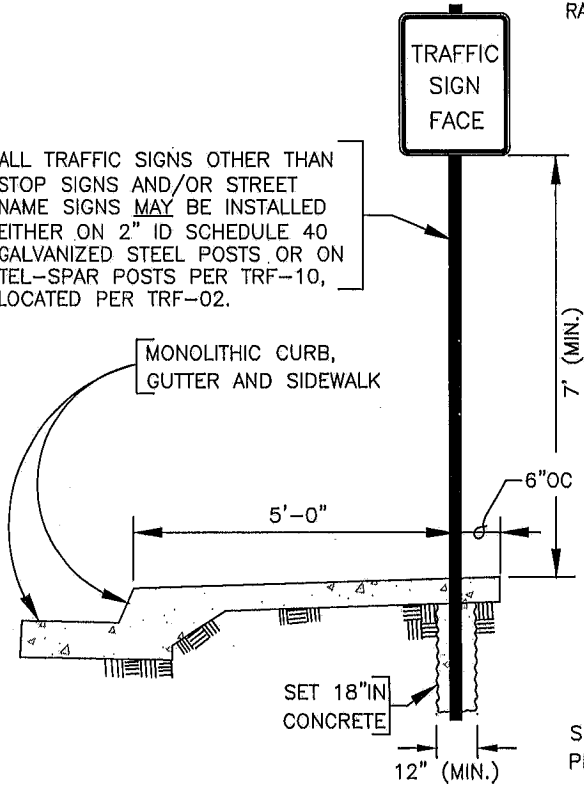

DETAIL "A"
NO SCALE

- SEVERAL ORDINANCES IN THE CITY OF CHULA VISTA CITY CODE PROHIBIT THE OBSTRUCTION OF REGULATORY SIGNS IN THE CITY:
- 12.12.040 OBSTRUCTING PUBLIC WAYS WITH VEGETATION PROHIBITED.
 - 12.12.120 VISION CLEARANCE-INTERSECTION REQUIREMENTS.
 - 12.32.040 APPROVAL AND PERMIT REQUIRED.
 - 12.32.150 TRIMMING REGULATIONS-OWNER RESPONSIBILITY-CITY TO PERFORM WORK WHEN.
 - 12.32.190 MAINTENANCE OF PUBLIC RIGHT-OF-WAY BY PROPERTY OWNER.

REVISION	BY	APPROVED	DATE
ORIGINAL			2/90
REVISION	CVM	C. SWANSON	11/02
REVISION	DPH	W. VALLE	11/17

CITY OF CHULA VISTA
ENGINEERING & CAPITAL PROJECTS
STANDARD DRAWING

TYPICAL SIGN POST PLACEMENT

William S. Valle
WILLIAM S. VALLE 11/21/2017
CITY ENGINEER

TRF-02

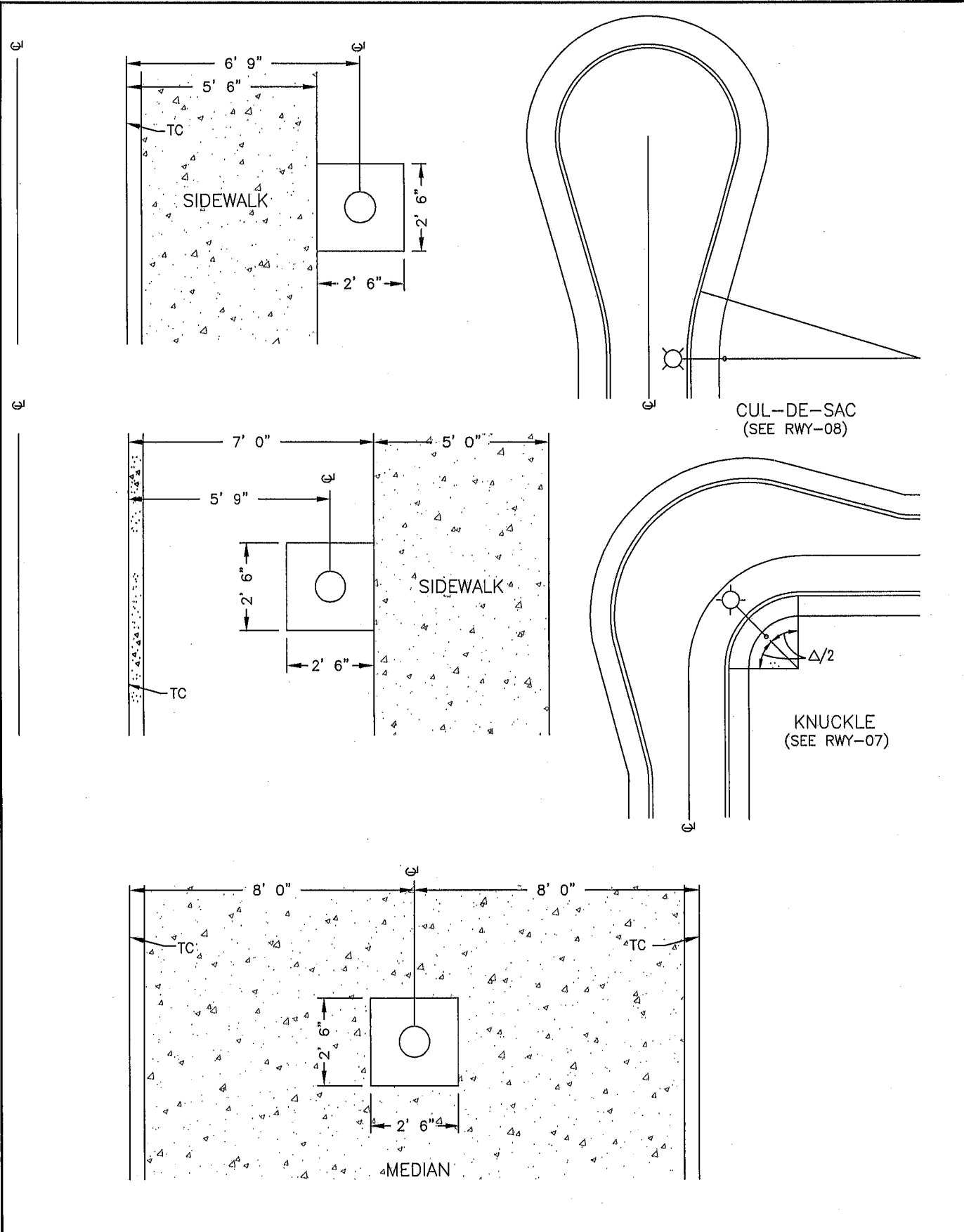

REVISION	BY	APPROVED	DATE
ORIGINAL			2/90
REVISION	CVM	C. SWANSON	11/02
REVISION	DPH	W. VALLE	11/17

CITY OF CHULA VISTA
ENGINEERING & CAPITAL PROJECTS
STANDARD DRAWING

STREET LIGHT LOCATIONS

William S. Valle
WILLIAM S. VALLE 11/21/2017
CITY ENGINEER

TRF-03

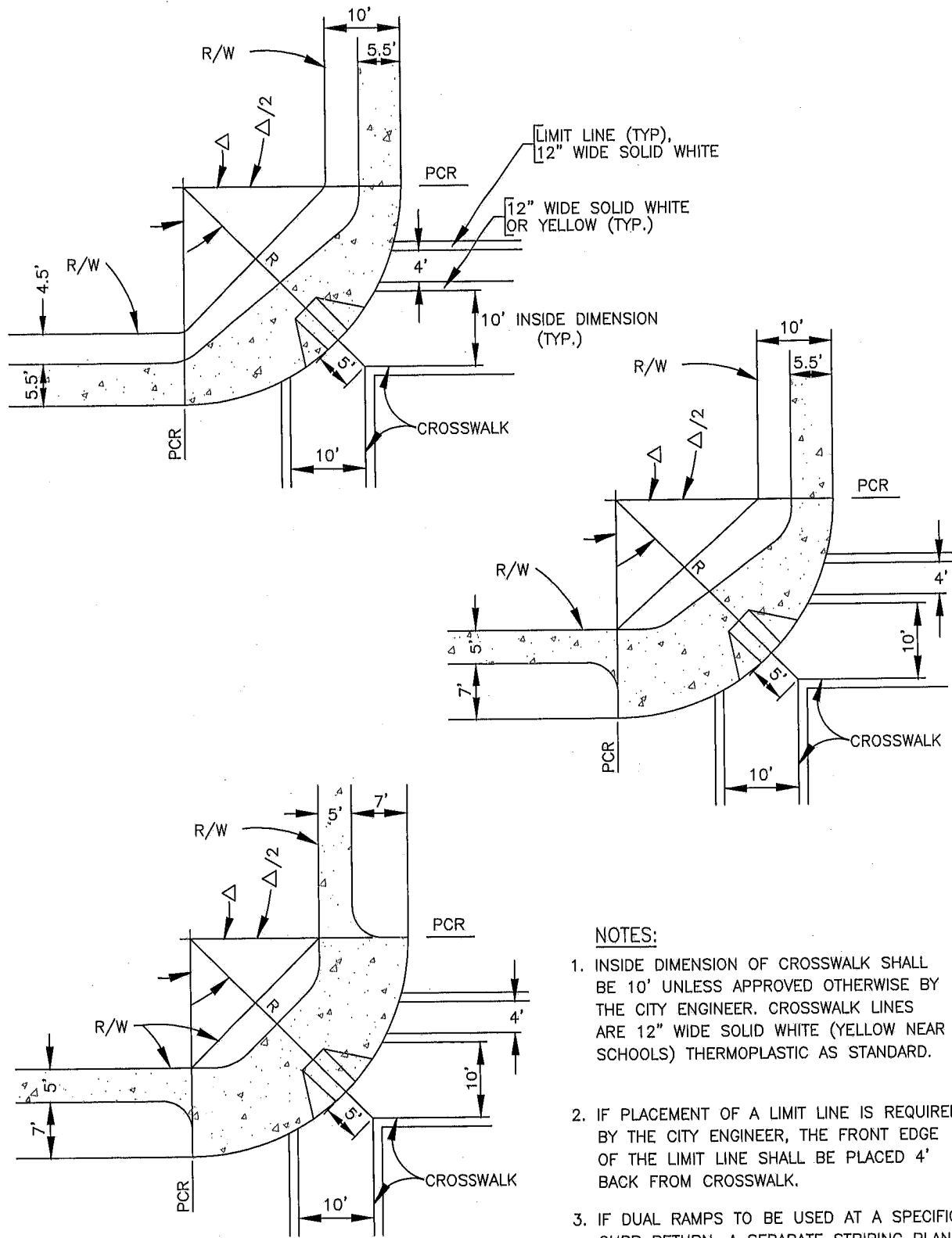

NOTES:

1. INSIDE DIMENSION OF CROSSWALK SHALL BE 10' UNLESS APPROVED OTHERWISE BY THE CITY ENGINEER. CROSSWALK LINES ARE 12" WIDE SOLID WHITE (YELLOW NEAR SCHOOLS) THERMOPLASTIC AS STANDARD.
2. IF PLACEMENT OF A LIMIT LINE IS REQUIRED BY THE CITY ENGINEER, THE FRONT EDGE OF THE LIMIT LINE SHALL BE PLACED 4' BACK FROM CROSSWALK.
3. IF DUAL RAMPS TO BE USED AT A SPECIFIC CURB RETURN, A SEPARATE STRIPING PLAN SHALL BE SUBMITTED FOR APPROVAL BY THE CITY ENGINEER.

REVISION	BY	APPROVED	DATE
ORIGINAL			2/90
REVISION	CVM	C. SWANSON	11/02
REVISION	DPH	W. VALLE	11/17

CITY OF CHULA VISTA
ENGINEERING & CAPITAL PROJECTS
STANDARD DRAWING

TYPICAL SIDEWALK AND CROSSWALK
LOCATIONS

William S. Valle
WILLIAM S. VALLE 11/21/2017
CITY ENGINEER

TRF-04

NIPPLES OF SUFFICIENT LENGTH TO PROVIDE NECESSARY LATERAL ADJUSTMENT OF HEADS

1 1/2" STANDARD PIPE FRAMEWORK

12" RED (L.E.D., UNLESS OTHERWISE SPECIFIED)

12" AMBER (L.E.D., UNLESS OTHERWISE SPECIFIED)

12" GREEN (L.E.D., UNLESS OTHERWISE SPECIFIED)

SPECIAL 90° ELBOW AND FITTINGS

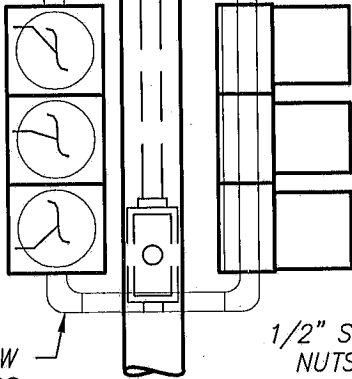

ELEVATION-TYPICAL
NO SCALE

FRONT VIEW

11" X 5" X 3 1/2" ALUMINUM TERMINAL BOX AND COVER

SEAL AROUND OPENING

CABLE GUIDE

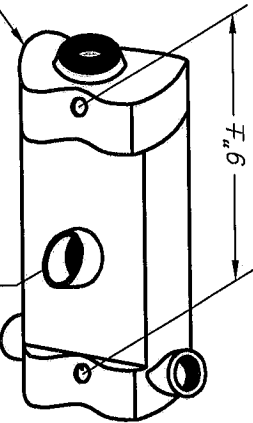
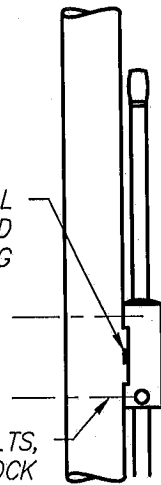

NOTES:
BRACKET MOUNTINGS SHALL BE ON SIDE OF POLE AWAY FROM TRAFFIC

BRACKET MOUNTING
NO SCALE

SIDE VIEW

TERMINAL BOX
NO SCALE

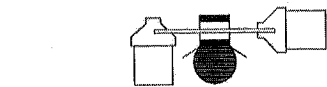

CURB LINE

12" RED (L.E.D., UNLESS OTHERWISE SPECIFIED)

12" AMBER (L.E.D., UNLESS OTHERWISE SPECIFIED)

12" GREEN (L.E.D., UNLESS OTHERWISE SPECIFIED)

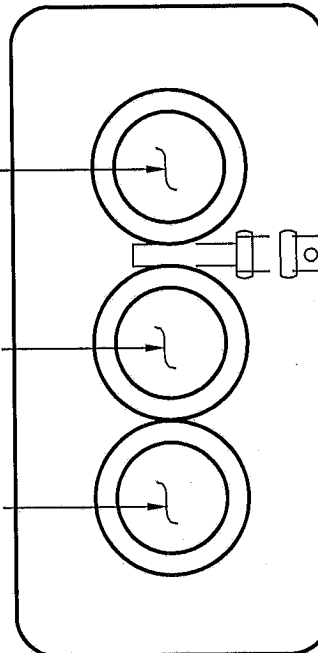

2" STANDARD PIPE MAST ARM

NUTS

BRONZE ELEVATOR PLUMBIZER

CONNECTING WASHERS

1/2" CARRIAGE BOLTS & NUTS.

NOTES:

PLUMB AND SECURE SIGNAL HEAD, THEN DRILL 7/16" HOLE THRU MAST ARM IN LINE WITH HOLE IN SLIPFITTER. PLACE 3/8" GALVANIZED BOLT WITH WASHER UNDER HEAD THRU HOLE & SECURE WITH WASHER AND TWO NUTS.

ELEVATOR PLUMBIZER ASSEMBLY
NO SCALE

REVISION	BY	APPROVED	DATE
ORIGINAL			12/67
REVISION	CM	CVM	11/02
REVISION	DPH	W. VALLE	11/17

CITY OF CHULA VISTA
ENGINEERING & CAPITAL PROJECTS
STANDARD DRAWING

William S. Valle
WILLIAM S. VALLE 11/21/2017
CITY ENGINEER

SIGNAL HEAD MOUNTING BRACKET
AND MAST ARM INSTALLATION

TRF-05

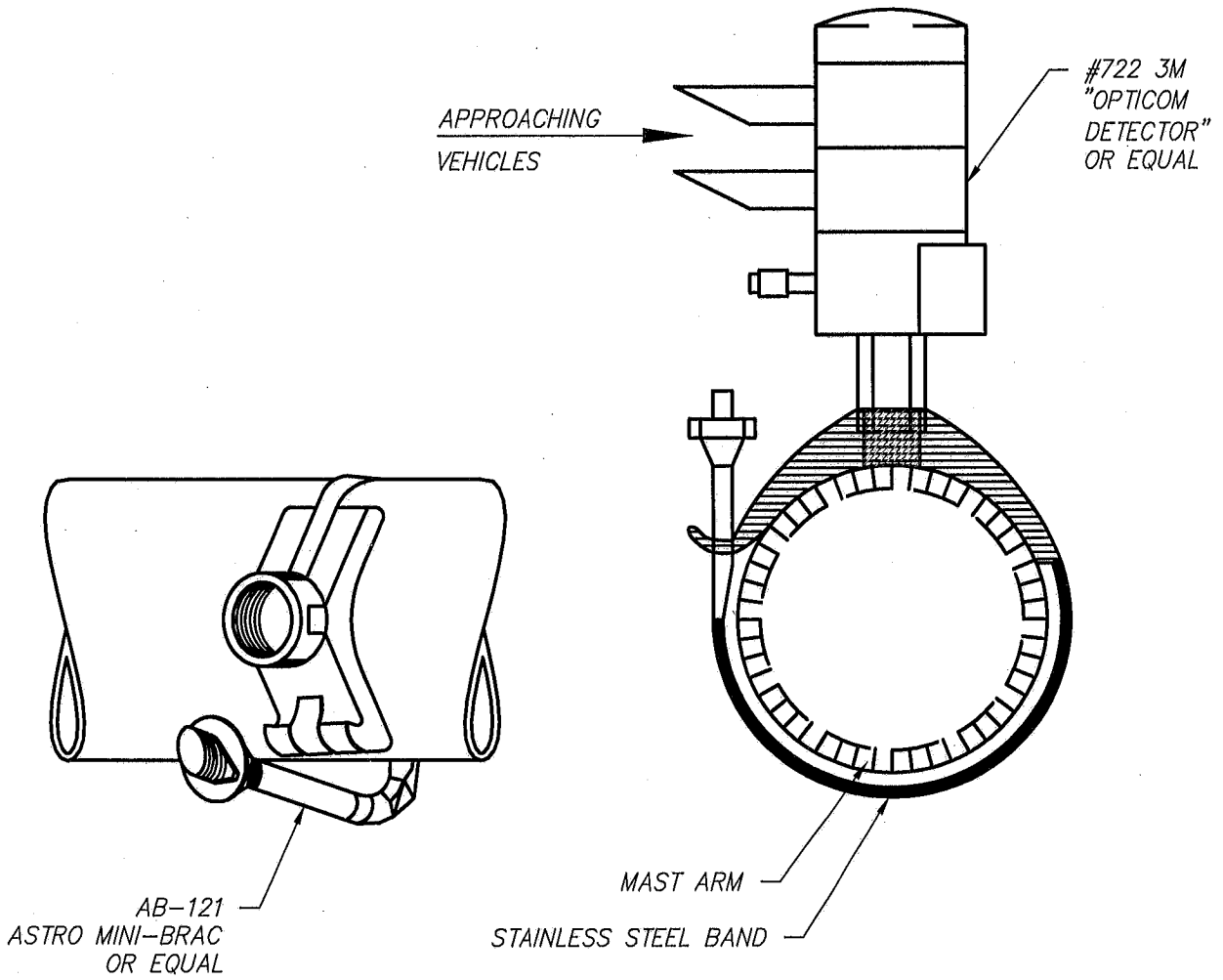

EMERGENCY VEHICLE PRE-EMPTION (EVPE) DETECTOR
 NO SCALE MOUNTING DETAILS

REVISION	BY	APPROVED	DATE
ORIGINAL			3/83
REVISION	CM	C. SWANSON	11/02
REVISION	DPH	W. VALLE	11/17

CITY OF CHULA VISTA
 ENGINEERING & CAPITAL PROJECTS
 STANDARD DRAWING

EVPE DETECTOR

William S. Valle
 WILLIAM S. VALLE 11/21/2017
 CITY ENGINEER

TRF-06

STOCK NO.	SIZE	MATERIAL & FINISH CODE		BORDER
V14F-909EX-2C1P V14F-909EX-2C2P	9" HEIGHT BY VARIABLE LENGTH 24" MINIMUM	ALUMINUM EXTRUSION PER CALTRANS 6061T6 OR 5052-H38 ALLOY MATERIAL .250" BULB WITH .091" WEB ONLY		3/8" (9.53MM)
LETTER COLOR	BK/GR COLOR	HOLES	HOLE \varnothing	RADIUS
REFLECTIVE WHITE *REFLECTIVE BLUE	REFLECTIVE BLUE *REFLECTIVE WHITE	TWO HOLES TOP & TWO HOLES BOTTOM	4-11/16" ON CENTERS	SQUARE CORNERS

* FOR PRIVATE STREETS.

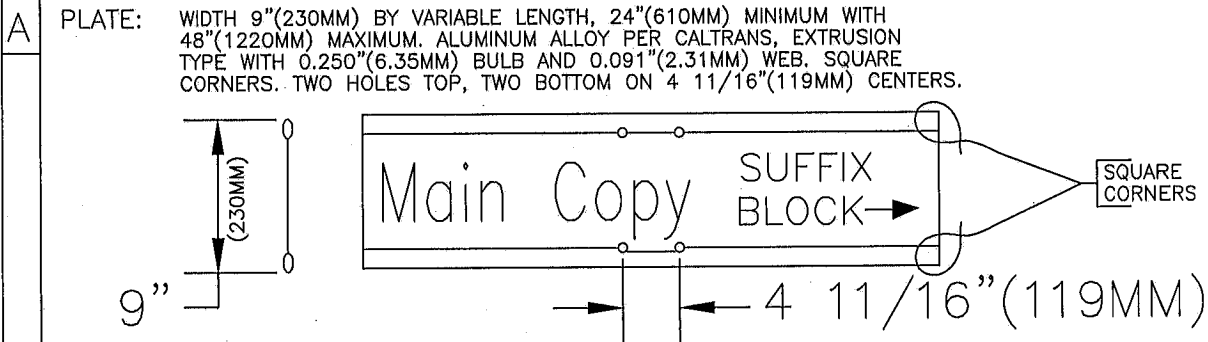

B LEGEND: TRAFFIC STYLE REFLECTIVE LETTERS, BLUE OR WHITE:
 MAIN COPY 6"(150MM) U.C., 4-1/2"(114MM) L.C.: FIFTEEN(15) LETTERS MAXIMUM,
 EVERY TWO LOWER CASE "i" COUNTS AS ONE LETTER.
 SUFFIX 3"(75MM) U.C.: BLOCK NUMBERS 3"(75MM); ARROW 2"(50MM) X 3.55"(90MM).

**
 24"(610MM),
 30"(760MM),
 36"(915MM),
 42"(1070MM),
 48"(1220MM)

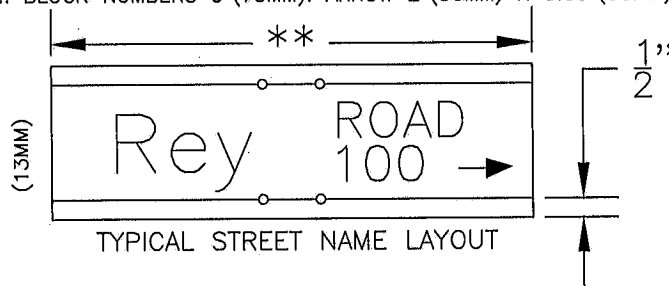

C CROSSPIECE: V14F-909EX-90°

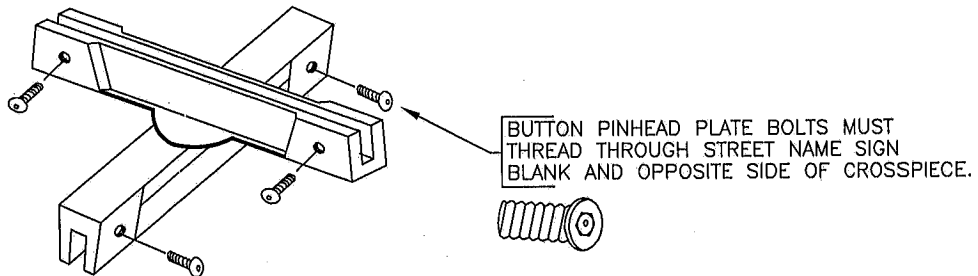

STREET NAME SIGN SYSTEM

SHEET 1 OF 5

REVISION	BY	APPROVED	DATE
ORIGINAL			7/90
REVISION	CM	C. SWANSON	11/02
REVISION	DPH	W. VALLE	11/17

CITY OF CHULA VISTA
 ENGINEERING & CAPITAL PROJECTS
 STANDARD DRAWING

STREET NAME SIGNS

William S. Valle
 WILLIAM S. VALLE 11/21/2017
 CITY ENGINEER
 TRF-07

D CAP: V14F-909EX-2C TO FIT 2" I.D. GALVANIZED STEEL PIPE

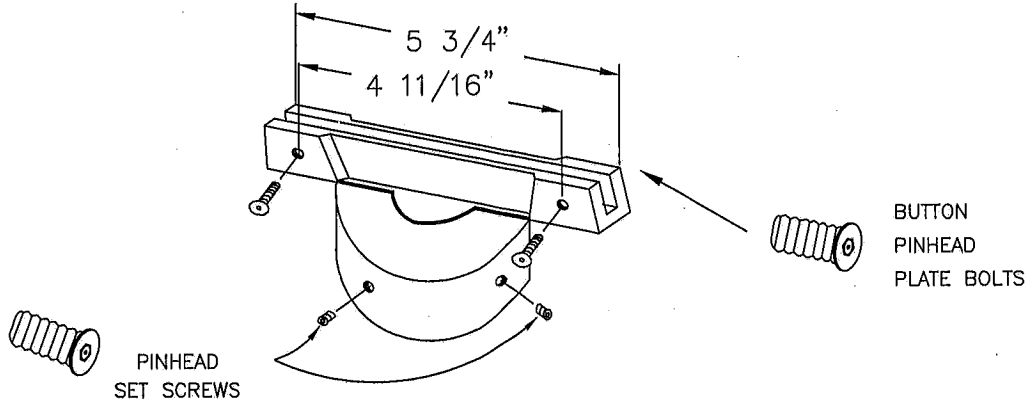

E MOUNTING: V14F-90EX-2C2P ILLUSTRATED

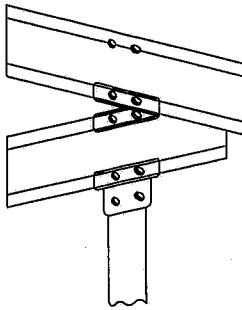

F SPECIFICATION: V14F-909EX-2C1P ONE NAME ASSEMBLY OR
V14F-909EX-2C2P TWO NAME ASSEMBLY

9" WIDTH x VARIABLE, 24" LENGTH MINIMUM, 48" MAXIMUM LENGTH. EXTRUSION TYPE ALUMINUM BLADE WITH .250" BULB AND .091" WEB. REFLECTIVE BLUE BACKGROUND, DOUBLE FACED. SQUARE CORNER. TWO HOLES TOP, TWO HOLES BOTTOM ON 4 11/16" CENTERS.

TRAFFIC STYLE LETTERS REFLECTIVE WHITE 6" U.C. AND 4 1/2" L.C. MAIN COPY. SUFFIX 3" U.C. ON TOP LINE, 3" BLOCK NUMBERS SECOND LINE WITH 2" x 3.55" ARROW TO THE RIGHT.

90° CROSS PIECE COMPLETE WITH BUTTON PIN HEAD PLATE BOLTS. BOLTS MUST THREAD THROUGH STREET NAME SIGN BLANK AND OPPOSITE SIDE OF CROSSPIECE. CAP TO FIT 2" I.D. PIPE, WITH PIN HEAD SET SCREWS AND BUTTON PIN HEAD PLATE BOLTS, PURSUANT TO CITY OF CHULA VISTA SPECIFICATIONS.

STREET NAME SIGN SYSTEM

NOTE: FORMERLY CVDS 35
NOTE: FORMERLY CVDS 33

SHEET 2 OF 5

REVISION	BY	APPROVED	DATE	CITY OF CHULA VISTA ENGINEERING & CAPITAL PROJECTS STANDARD DRAWING	 WILLIAM S. VALLE 11/21/2017 CITY ENGINEER
ORIGINAL			7/72		
REVISION	CM	C. SWANSON	11/02		
REVISION	DPH	W. VALLE	11/17		
STREET NAME SIGNS DETAILS				TRF-07	

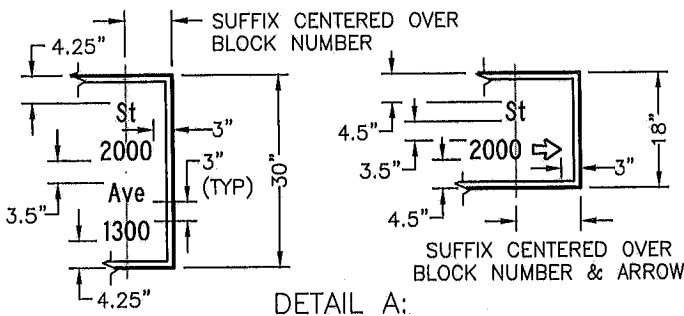
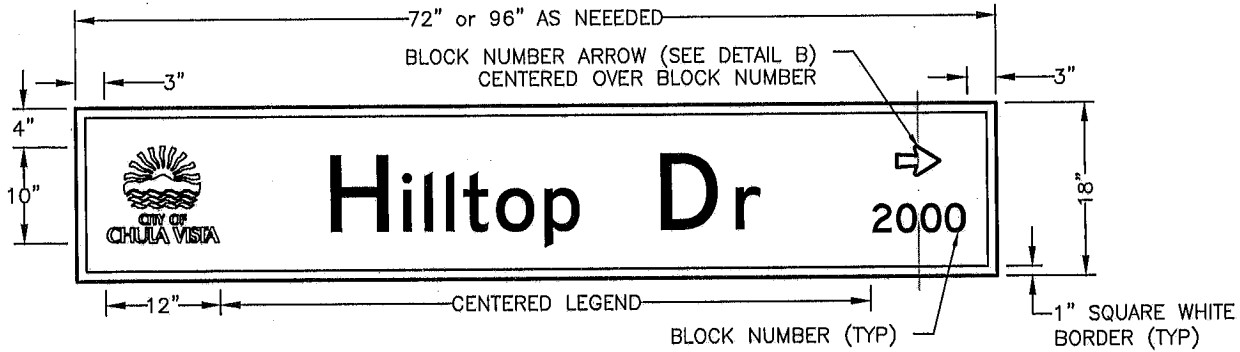

DETAIL A:
SUFFIX PLACEMENT RESTRICTIVE CONDITIONS

NOTES:

1. DG3 REFLECTIVE SHEETING PER ASTM D 4956 TYPE XI STANDARDS
2. GREEN BACKGROUND WITH WHITE FHWA HIGHWAY GOTHIC FONT. STREET NAME 8" UPPERCASE AND 6" LOWERCASE. BLOCK NUMBER 3".
3. 0.05 ALUMINUM SUBSTRATE
4. RELATIVE DIMENSIONS FOR BLOCK AND STREET NAME ARROWS (DETAILS B AND C) PER STANDARD HIGHWAY SIGN AND MARKINGS DETAIL S-2

GUIDANCE FOR FONT SERIES, SIGN SIZE AND PLACEMENT: DEFAULT TO AN 18" X 72" SIGN BLANK AND SERIES E FONT. PLACE ABBREVIATED SUFFIX IN-LINE WITH STREET NAME. FOR ALPHA STREET NAMES ONLY, SPELL OUT "STREET". TO ACHIEVE LEGEND FIT USE THE FOLLOWING IN ORDER OF PRIORITY: 1.) SERIES D 2.) ABBREVIATIONS (SEE DETAIL CVD-TRXX SHEET 3) 3.) SERIES C FONT. 4.) 96" X 18" SIGN BLANK WITH SERIES E FONT FOLLOWED BY D, C AND B SERIES. 5.) STACK STREET SUFFIX OVER THE BLOCK NUMBER AND ARROW USING 3" FONT (SEE DETAIL A). USE SERIES E FONT FOLLOWED BY D, C AND B SERIES. ONLY ONE SERIES FONT SHALL BE USED PER SIGN.

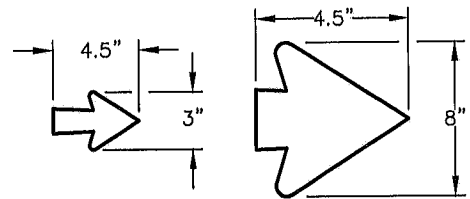

DETAIL B:
BLOCK NUMBER
ARROW

DETAIL C:
STREET NAME
DIRECTIONAL
ARROW

REVISION	BY	APPROVED	DATE
ORIGINAL	DPH	W. VALLE	11/17

CITY OF CHULA VISTA
ENGINEERING & CAPITAL PROJECTS
STANDARD DRAWING

OVERHEAD STREET NAME SIGNS

William S. Valle
WILLIAM S. VALLE 11/21/2017
CITY ENGINEER

TRF-07

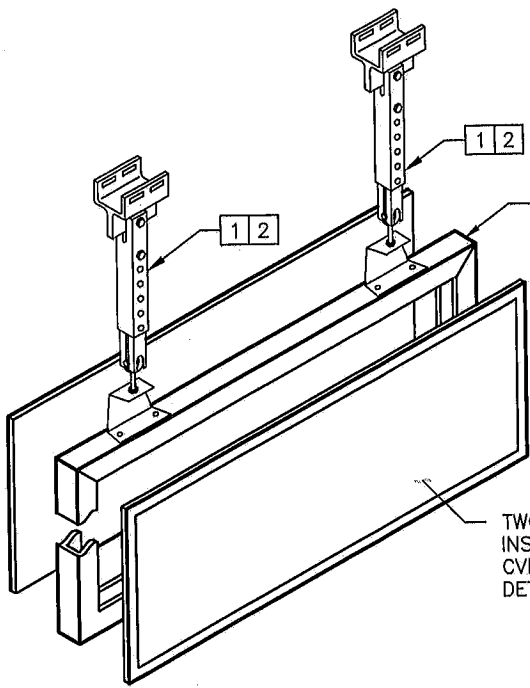

0.50 ALUMINUM U CHANNEL GALVANIZED PER CALTRANS SPECIFICATION XXX

TWO SIGNS PER DUAL SIDED INSTALLATION. SEE DETAIL CVD-TRXX SHEET 1 FOR SIGN DETAILS.

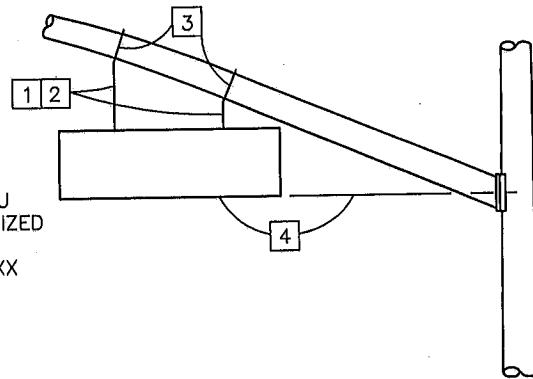

DETAIL E:
SIGN MOUNTING

DETAIL D:
SIGN FRAME AND ATTACHMENT

NOTES:

1. BRACKET, 1/4" X 1 1/2" MINIMUM, LENGTH VARIABLE
2. BRACKET, 2-PIECE ADJUSTABLE. 1/4" X 1 1/2" MINIMUM. TWO 1/2" Ø HEXAGON HEAD BOLTS WITH NUTS AND LOCKWASHERS
3. 3/4" X 0.02" MINIMUM ROUNDED EDGE STAINLESS STEEL STRAP WITH 2" LONG BEND UNDER BUCKLE. IF ATTACHING TO A MULTISIDED SECTION BEND UNDER SECTION SHALL BE LONG ENOUGH TO CONTACT AT LEAST 3 CORNERS.
4. ADJUST FIXTURE LEVEL NO LOWER THAN CENTER OF SIGNAL MAST ARM CONNECTION.

NOTES THIS PAGE ARE FOR REFERENCE ONLY. USE CALTRANS STANDARD DRAWING ES-7P FOR THE LATEST STANDARD DETAILS FOR SIGN HARDWARE, PLACEMENT AND NOTES.

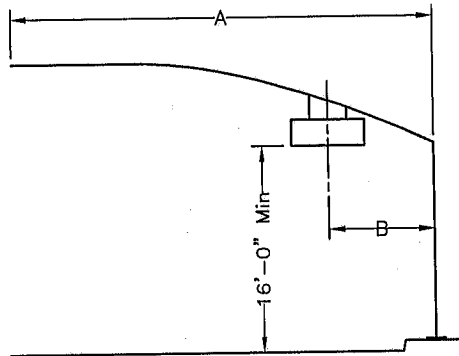

DETAIL F:
SIGN PLACEMENT

SIGN PLACEMENT

A	B	
PROJECTED LENGTH	72" SIGN	96" SIGN
20'-0"	7'-10"	8'-10"
25'-0"	9'-2"	10'-2"
30'-0"	9'-6"	10'-6"
35'-0"	10'-6"	11'-6"
40'-0"	12'-6"	13'-6"
45'-0"		
50'-0"		
55'-0"		
60'-0"		
65'-0"		

REVISION	BY	APPROVED	DATE
ORIGINAL	DPH	W. VALLE	11/17

CITY OF CHULA VISTA
ENGINEERING & CAPITAL PROJECTS
STANDARD DRAWING
OVERHEAD STREET NAME SIGN
DETAILS

William S. Valle
WILLIAM S. VALLE 11/21/2017
CITY ENGINEER
TRF-07

NAME TO BE
ABBREVIATED ABBREVIATION

Avenida	Avd
Avenue	Ave
Boulevard	Blvd
Calle	Cl
Callejon	Clj
Caminito	Cmto
Camino	Cam
Center	Ctr
Circle	Cir
Corte	Cte
Court	Ct
Creek	Ck
Drive	Dr
East	E
Elementary	Elem
Entrance	Ent
Estate	Est
Freeway	Fwy
Gardens	Gdns
Heights	Hts
Highlands	Hghlds
Highway	Hwy
Lake	Lk
Lane	Ln
Loop	Lp
Meadow	Mdw
Mount	Mt
Mountain	Mnt
North	N
Park	Pk

NAME TO BE
ABBREVIATED ABBREVIATION

Parkway	Pkwy
Paseo	Pas
Place	Pl
Plaza	Plz
Rambla	Rmbla
Ranch	Rch
Rancho	Rcho
Ridge	Rdg
River	Riv
Road	Rd
Saint	St
Santa	Snta
School	Sch
South	S
Spring	Spg
Springs	Spgs
Station	Sta
Street	St
Summit	Smt
Terrace	Ter
Trail	Tr
Truck Trail	TT
Valley	Vly
View	Vw
Village	Vlg
Vista	Vis
Way	Wy
West	W
Driveway	Dwy

SHEET 5 OF 5

REVISION	BY	APPROVED	DATE	CITY OF CHULA VISTA ENGINEERING & CAPITAL PROJECTS STANDARD DRAWING	<i>William S. Valle</i> WILLIAM S. VALLE 11/21/2017 CITY ENGINEER
ORIGINAL	DPH	W. VALLE	11/17		
				OVERHEAD STREET NAME SIGN ABBREVIATIONS	TRF-07

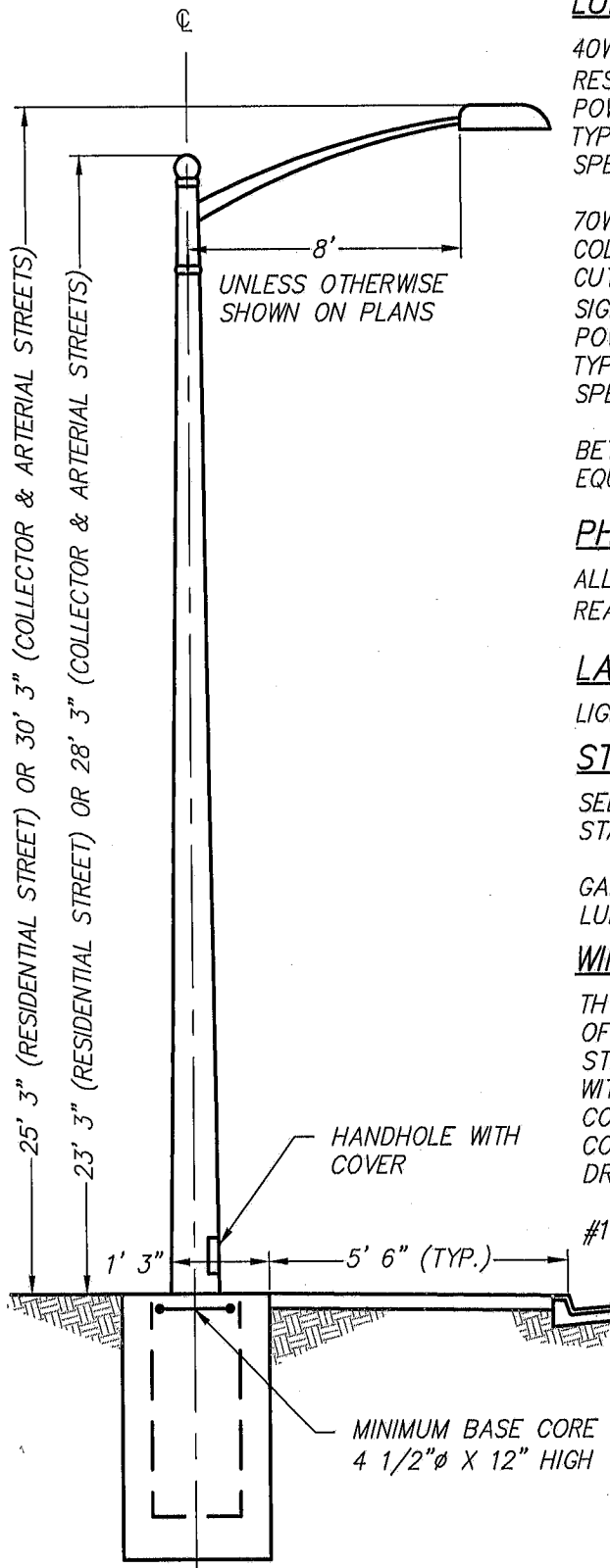

LUMINAIRE:

40W-60W L.E.D. LUMINAIRE WITH CUT-OFF OPTICS ON RESIDENTIAL STREET. USE MULTI-VOLT (120V/240V) POWER SUPPLY, TWIST-LOCK P.E.C. RECEPTACLE AND I.E.S. TYPE II LIGHT DISTRIBUTION PATTERN UNLESS OTHERWISE SPECIFIED.

70W-90W L.E.D. LUMINAIRE WITH CUT-OFF OPTICS ON COLLECTOR STREET. 100W-150W L.E.D. LUMINAIRE WITH CUT-OFF OPTICS ON ARTERIAL STREET AND ON TRAFFIC SIGNAL SAFETY LIGHTING. USE MULTI-VOLT (120V/240V) POWER SUPPLY, TWIST LOCK P.E.C. RECEPTACLE AND I.E.S. TYPE III LIGHT DISTRIBUTION PATTERN UNLESS OTHERWISE SPECIFIED.

BETALED, GE, LED ROADWAY, LEOTEK, OR APPROVED EQUAL.

PHOTO ELECTRIC CONTROL:

ALL LUMINAIRES/FIXTURES SHALL BE "ADAPTIVE CONTROL READY" PER CITY OF CHULA VISTA SPECIFICATIONS.

LAMP:

LIGHT EMITTING DIODE (L.E.D.)

STANDARD:

SEE SECTION 307 OF THE CITY OF CHULA VISTA STANDARD SPECIAL PROVISIONS. TWO-INCH STANDARD

GALVANIZED STEEL OR ALUMINUM PIPE BRACKET FOR LUMINAIRE. HANDLE TO FACE STREET.

WIRING:

THW STRANDED COPPER TO SERVICE POINT. NEUTRAL LEG OF LIGHTING CONDUCTORS GROUNDED IN BASE OF STANDARD. HOT LEG OF LIGHTING CONDUCTORS FUSED WITH 10-AMPERE MIDGET FERRULE TYPE FUSE IN PLUG CONNECTOR, IN BASE OF STANDARD. SIZE ALL CONDUCTORS FOR MAXIMUM THREE PERCENT VOLTAGE DROP IN ALL STREET LIGHT CIRCUITS.

#10 THW STRANDED COPPER IN STANDARD.

GENERAL NOTES:

1. LUMINAIRE & PHOTO CELL SHALL BE APPROVED BY CITY ENGINEER PRIOR TO INSTALLATION.
2. STREET LIGHT PLANS SHALL SHOW WIRING FROM SERVICE POINT TO STREET LIGHTS, AND SHALL BE APPROVED BY CITY ENGINEER PRIOR TO INSTALLATION.

FOUNDATION & GROUNDING:

SEE TRF-08
REFER TO MANUFACTURER'S DETAIL FOR ANCHOR BOLT SPACING.

SHEET 1 OF 3

REVISION	BY	APPROVED	DATE
ORIGINAL			7/80
REVISION	CVM	C. SWANSON	11/02
REVISION	DPH	W. VALLE	11/17

CITY OF CHULA VISTA
ENGINEERING & CAPITAL PROJECTS
STANDARD DRAWING

William S. Valle
WILLIAM S. VALLE 11/21/2017
CITY ENGINEER

STREET LIGHTING STANDARD

TRF-08

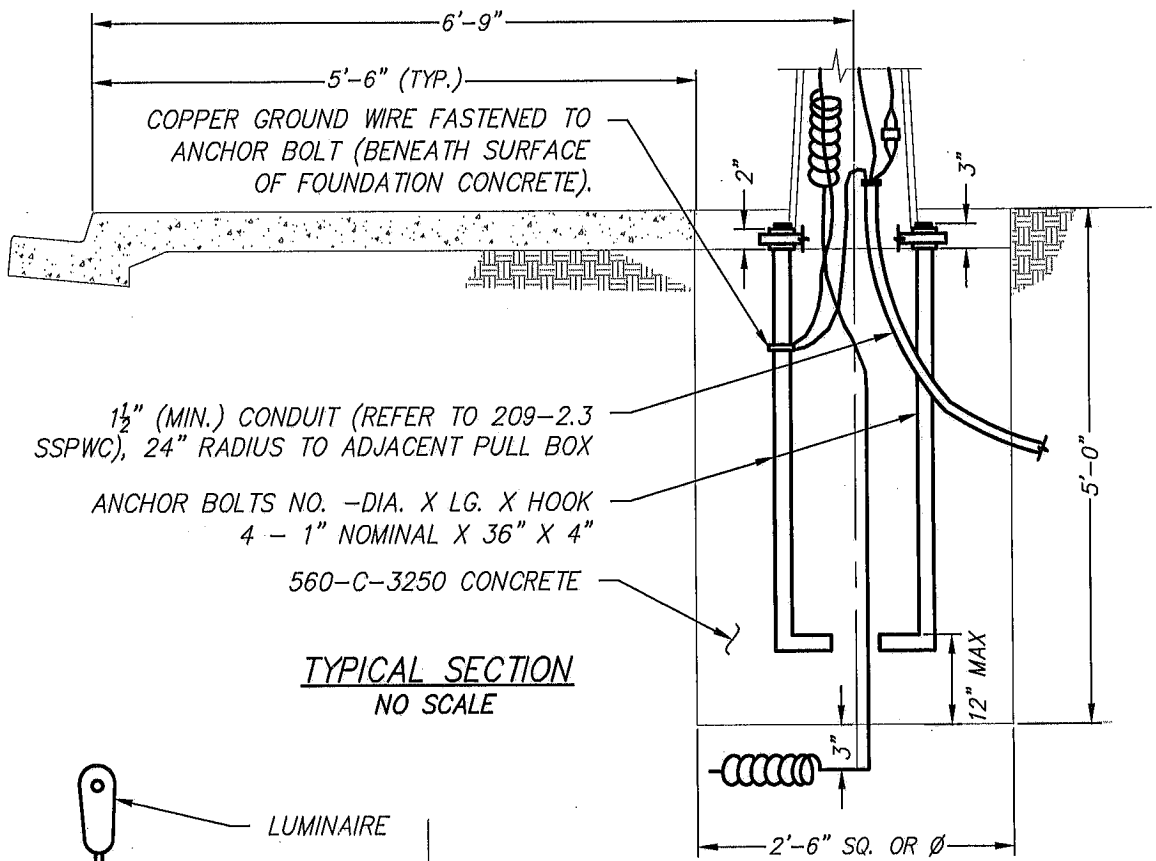

1 1/2" (MIN.) CONDUIT (REFER TO 209-2.3 SSPWC), 24" RADIUS TO ADJACENT PULL BOX

ANCHOR BOLTS NO. -DIA. X LG. X HOOK
4 - 1" NOMINAL X 36" X 4"

560-C-3250 CONCRETE

TYPICAL SECTION
NO SCALE

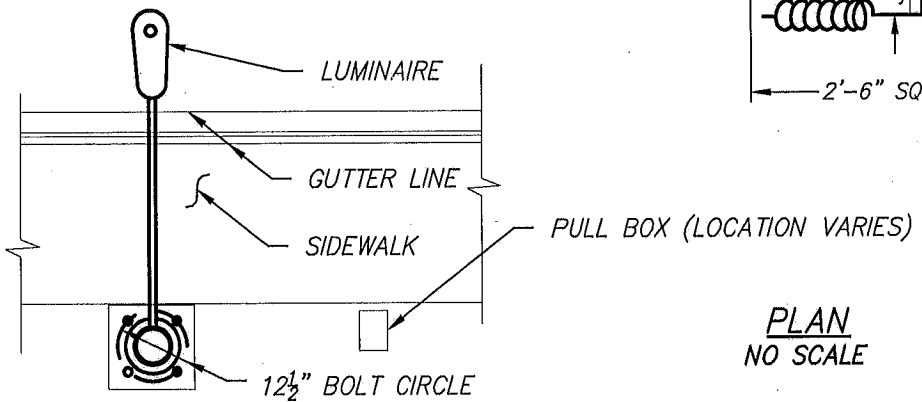

PLAN
NO SCALE

NOTES:

1. CONDUIT SHOULD BE RIGID STEEL OR PVC SCHEDULE 80, PLACED 30" TO 60" DEEP IN THE STREET OR 18" TO 36" DEEP BEHIND CURB LINE. REFER TO CHULA VISTA CONSTRUCTION STANDARD DWG. TRF-08 - STREET LIGHTING STANDARD.
2. WIRING - MINIMUM #8 THW STRANDED COPPER, 5/64" INSULATION TO SERVICE POINT. TWO CONDUCTORS: [1-RED OR BLACK, 1-WHITE (NEUTRAL), 120 VOLT] [2-RED OR BLACK, 1-GREEN #6, 240 VOLT], #10 THW STRANDED COPPER IN THE STANDARD.
3. EACH ANCHOR BOLT SHALL BE PROVIDED WITH 2 NUTS AND 2 WASHERS, GALVANIZED. THE TOP 8" OF ALL ANCHOR BOLTS AND ALL NUTS SHALL BE GALVANIZED. COMPLETED INSTALLATION WHEREIN ENDS OF ANCHOR BOLTS ARE EXPOSED SHALL HAVE BOLT ENDS CUT AND GROUND DOWN TO MAXIMUM EXPOSED LENGTH OF 1/4" ABOVE ANCHOR NUTS. BEVEL SHARP EDGES OF BOLTS.
4. SQUARE FOUNDATIONS SHALL BE INSTALLED IN NON-GRANULAR CLAY SOILS. CIRCULAR FOUNDATIONS MAY BE INSTALLED IN COURSE GRANULAR SOIL.
5. PULL BOXES SHALL BE PER CITY OF CHULA VISTA CONSTRUCTION STANDARD DWG. TRF-09.
6. STREET LIGHTING STD. (ELECTRICAL DETAILS) SHALL BE PER TRF-08.

REVISION	BY	APPROVED	DATE	CITY OF CHULA VISTA ENGINEERING & CAPITAL PROJECTS STANDARD DRAWING	<i>William S. Valle</i> WILLIAM S. VALLE CITY ENGINEER
ORIGINAL			3/83		
REVISION	CVM	C. SWANSON	11/02		
REVISION	DPH	W. VALLE	11/17		
				STREET LIGHT STANDARD FOUNDATION DETAIL	11/21/2017
					TRF-08

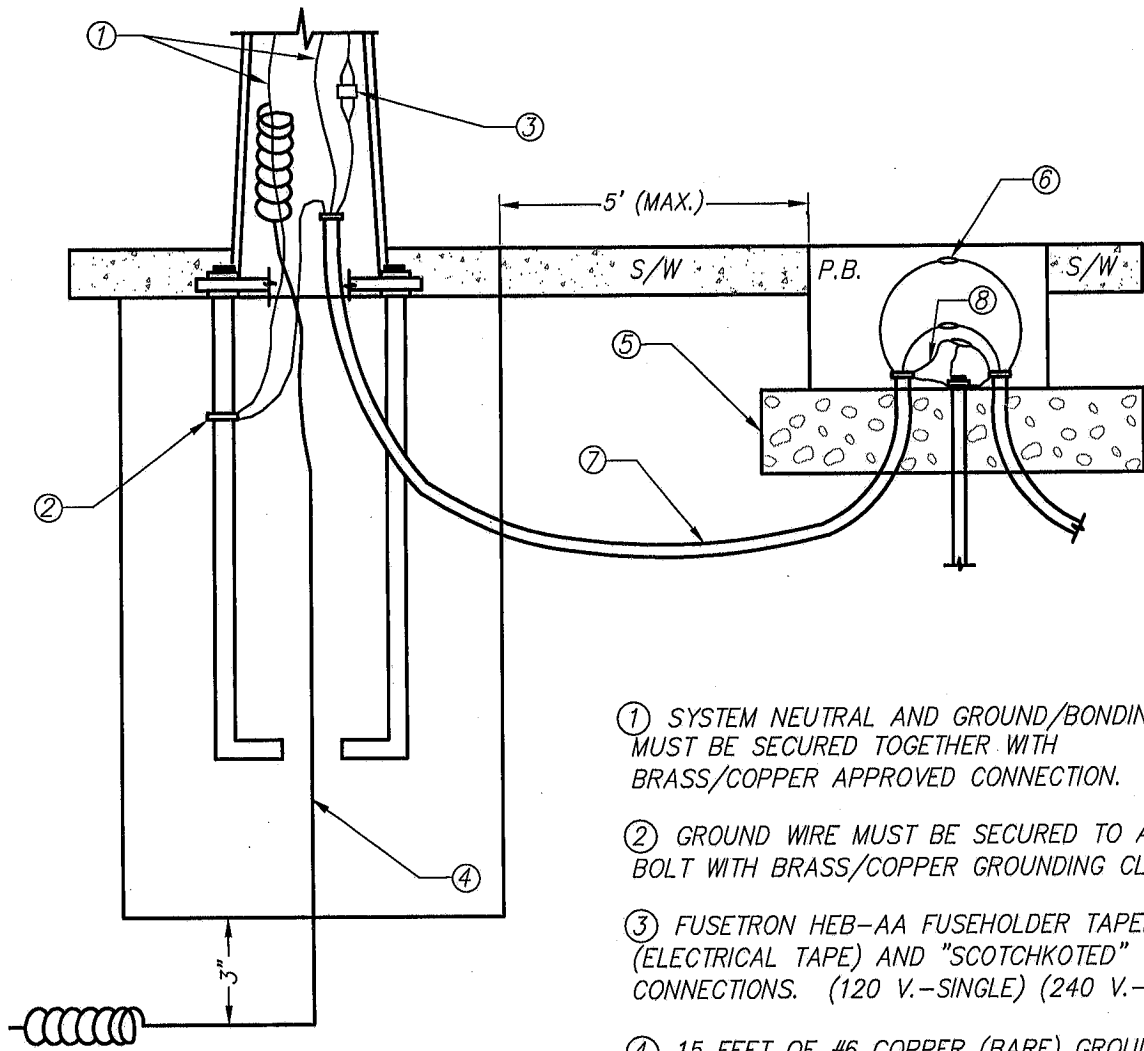

- ① SYSTEM NEUTRAL AND GROUND/BONDING WIRE MUST BE SECURED TOGETHER WITH BRASS/COPPER APPROVED CONNECTION.
- ② GROUND WIRE MUST BE SECURED TO ANCHOR BOLT WITH BRASS/COPPER GROUNDING CLAMP.
- ③ FUSETRON HEB-AA FUSEHOLDER TAPED (ELECTRICAL TAPE) AND "SCOTCHKOTED" AT CONNECTIONS. (120 V.-SINGLE) (240 V.-DUAL).
- ④ 15 FEET OF #6 COPPER (BARE) GROUND WIRE TO BE INSTALLED 3" BELOW THE FOUNDATION AND EXTENDED THROUGH THE @ NOTE 1.
- ⑤ GRAVEL BASE FOR PULL BOXES TO BE 6" DEEP AND 3" BEYOND THE EDGE OF THE PULL BOX. (SEE TRF-09).
- ⑥ ALL CONNECTIONS ARE TO BE TAPED (ELECTRICAL TAPE) AND "SCOTCHKOTED".
- ⑦ IF RIGID CONDUIT IS USED, IT SHALL BE BONDED TO THE NEUTRAL AND THE GROUND WIRE.
- ⑧ IF 240 V. SYSTEM, GROUND WIRE IS REQUIRED.

MINIMUM WIRE SPECIFICATIONS:

SERVICE RUN: #8 COPPER THW
 STRANDED POLE: #10 COPPER THW
 STRANDED GROUND AND BONDING: #6 COPPER (BARE)

STREET LIGHTING ELECTRICAL DETAILS:

SEE CHULA VISTA CONSTRUCTION STANDARDS NO. TRF-08, TRF-08, TRF-09, AND TRF-09 FOR CONSTRUCTION DETAILS.

REVISION	BY	APPROVED	DATE	CITY OF CHULA VISTA ENGINEERING & CAPITAL PROJECTS STANDARD DRAWING	 WILLIAM S. VALLE CITY ENGINEER
ORIGINAL			12/85		
REVISION	CVM	C. SWANSON	11/02		
REVISION	DPH	W. VALLE	11/17		
				STREET LIGHTING STANDARD ELECTRICAL DETAILS	TRF-08

INSCRIBE "TRAFFIC SIGNAL" WHEN CONTAINING SIGNAL CONDUCTOR.

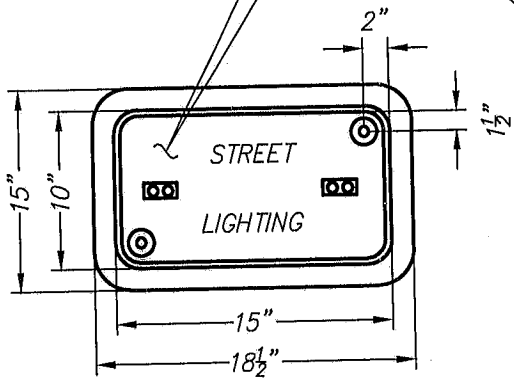

#3 1/2 P.B.

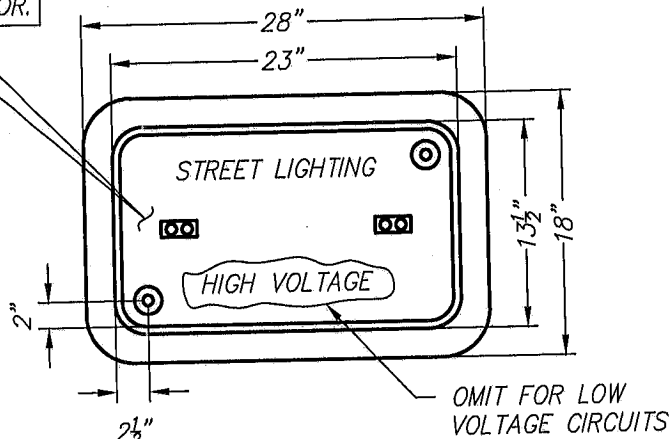

#5 P.B.

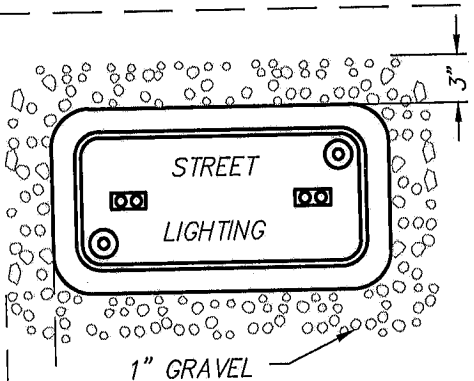

1" GRAVEL

TOP OF CURB OR SIDEWALK GRADE

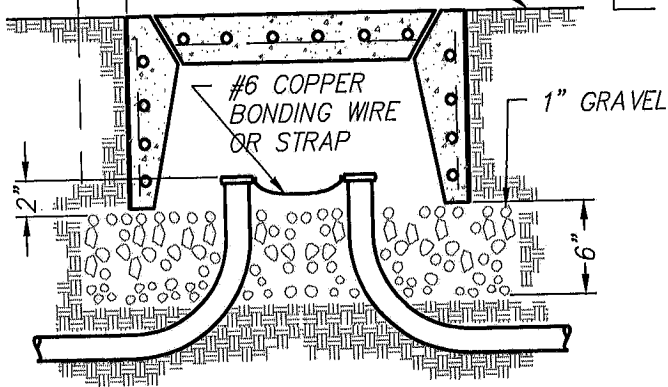

#6 COPPER BONDING WIRE OR STRAP

1" GRAVEL

PULL BOX REQUIREMENTS:

CALIFORNIA DEPARTMENT OF TRANSPORTATION STANDARD SPECIFICATIONS SECTION 86-2.06.

CHULA VISTA REQUIRED PULL BOX LOCATIONS:

1. ADJACENT TO SERVICE POINTS, TRANSFORMERS.
2. ADJACENT TO EVERY STREET LIGHTING STANDARD.
3. BOTH SIDES OF STREET CROSSINGS.
4. WHEN THE SERVICE POINT IS WITHIN 20' FEET OF THE STREET LIGHTING STANDARD, ONE PULL BOX IS SUFFICIENT.
5. TRAFFIC SIGNAL AND TELEPHONE INTERCONNECT: PULL BOXES SHALL BE #5 MINIMUM.

NOTES:

STEEL REINFORCING SHALL BE AS REGULARLY USED IN THE STANDARD PRODUCTS OF THE RESPECTIVE MANUFACTURER. PULL BOXES NOT TO BE CONSTRUCTED IN DRIVEWAY APPROACHES.

ALL BOXES IN VEHICLE TRAVEL WAY SHALL HAVE A TRAFFIC LOAD BEARING COVER.

REVISION	BY	APPROVED	DATE
ORIGINAL			12/67
REVISION	CM	C. SWANSON	11/02
REVISION	DPH	W. VALLE	11/17

CITY OF CHULA VISTA
ENGINEERING & CAPITAL PROJECTS
STANDARD DRAWING

William S. Valle
WILLIAM S. VALLE 11/21/2017
CITY ENGINEER

PULL BOXES

TRF-09

COLLECTORS/INDUSTRIALS/ARTERIALS

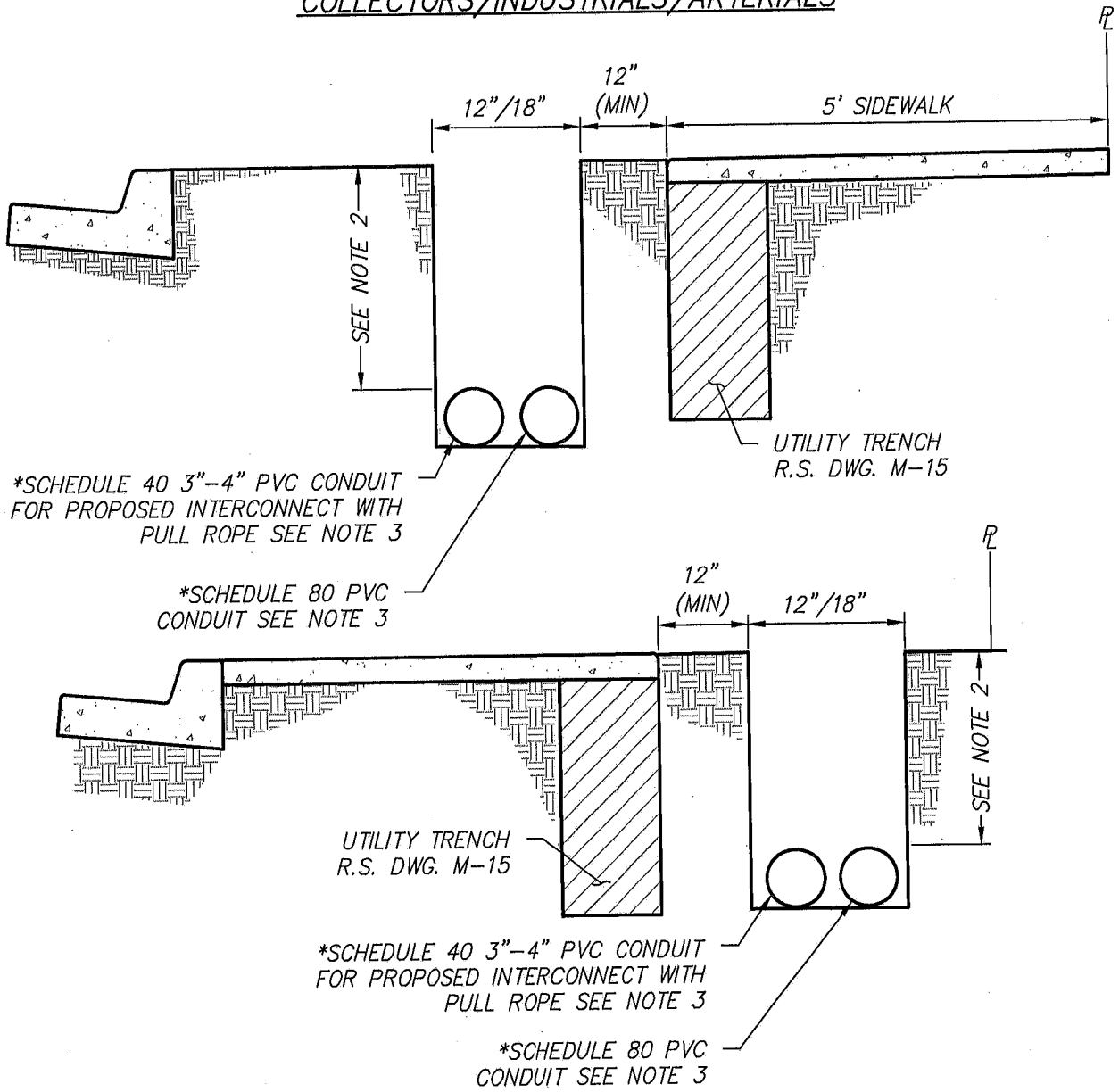

STREET LIGHT/TRAFFIC SIGNAL CONDUIT TRENCH - 18" DEEP MIN.
NOT TO SCALE

1. BACKFILL TO BE COMPACTED 90%.
2. CONDUIT SHALL BE PLACED A MINIMUM OF 30" BELOW GRADE IN STREET, AND A MINIMUM OF 18" BELOW GRADE BEHIND CURB.
3. PULL ROPE SHALL BE INSTALLED FOR FUTURE STREET LIGHT/TRAFFIC SIGNALS/INTERCONNECT.
4. CONDUCTOR TYPE & QUANTITY AS APPROVED BY CITY ENGINEER.
5. SEE TRF-09 FOR PULL BOX DETAILS.
6. * FOR COLLECTOR/INDUSTRIAL/ARTERIAL ROADWAYS USE AN 18" WIDE TRENCH.

REVISION	BY	APPROVED	DATE	CITY OF CHULA VISTA ENGINEERING & CAPITAL PROJECTS STANDARD DRAWING	 WILLIAM S. VALLE 11/21/2017 CITY ENGINEER
ORIGINAL			8/78		
REVISION	CM	C. SWANSON	11/02		
REVISION	DPH	W. VALLE	11/17		
				STREET LIGHT & TRAFFIC SIGNAL CONDUIT TRENCH	TRF-09

NOTES:

1. Structural steel tubing used for post and sleeves shall be galvanized 12 gauge cold rolled steel of the nominal dimensions shown hereon and shall meet the requirements of ASTM A446 Grade A.
2. Galvanizing shall be per ASTM A525. Posts and sleeves shall have 7/16" dia. holes spaced 1" o.c. $\pm 1/8"$ and shall have no more variation in straightness than 1/16" in 3'. Posts shall be square within $\pm 0.014"$, have twist no greater than 0.062" in 3' and have corner radii of 5/32" $\pm 1/64"$.
3. The signs shall be mounted on posts in accordance with Section 56, "Signs" of the CalTrans Standard Specifications. All fastening hardware is to be provided by the Contractor.

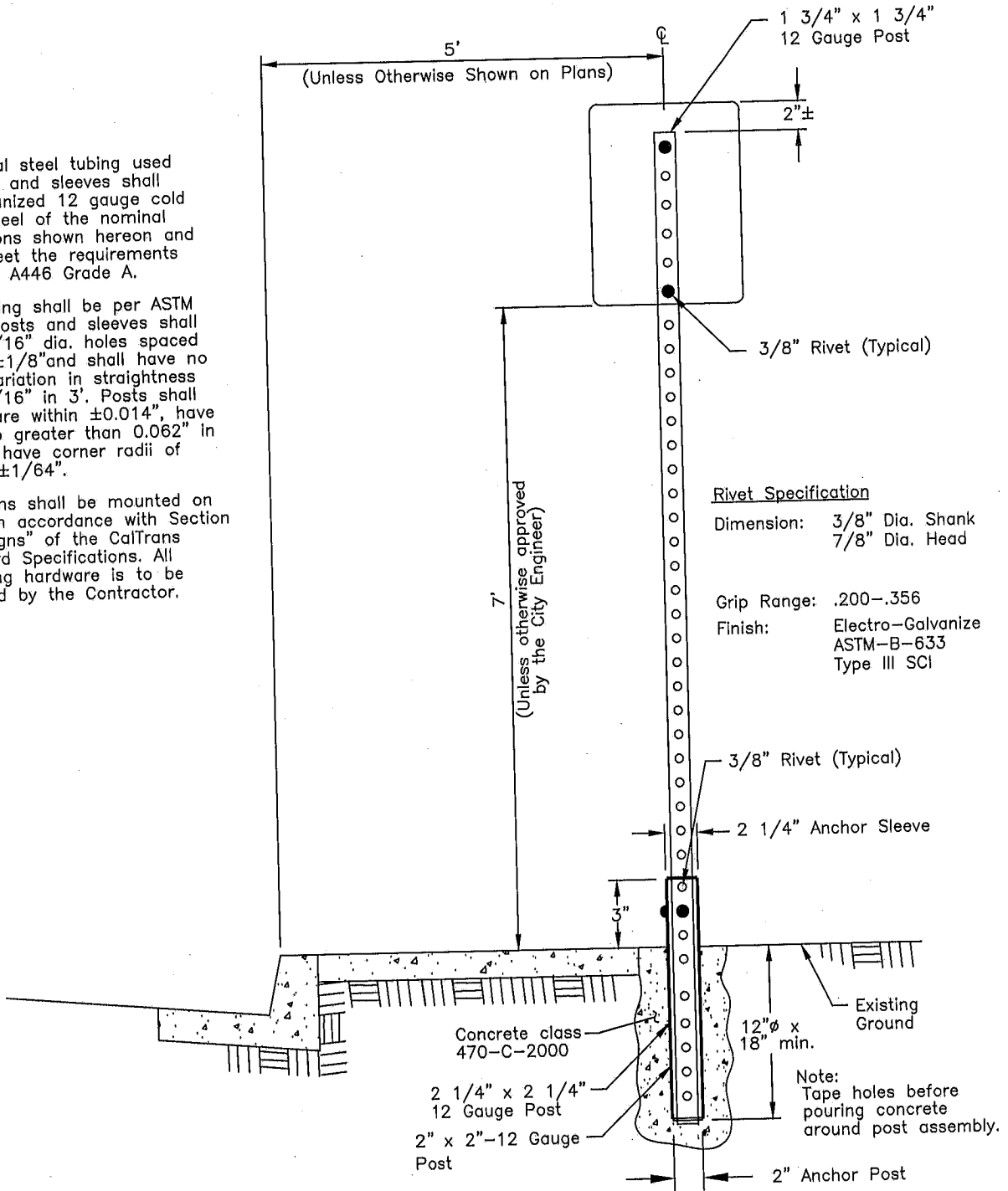

Rivet Specification
 Dimension: 3/8" Dia. Shank
 7/8" Dia. Head
 Grip Range: .200-.356
 Finish: Electro-Galvanize
 ASTM-B-633
 Type III SCI

SHEET 1 OF 2

REVISION	BY	APPROVED	DATE
ORIGINAL			2/95
REVISION	CVM	C. SWANSON	11/02
REVISION	DPH	W. VALLE	11/17

CITY OF CHULA VISTA
 ENGINEERING & CAPITAL PROJECTS
 STANDARD DRAWING

William S. Valle
 WILLIAM S. VALLE 11/21/2017
 CITY ENGINEER

BREAK-AWAY SIGN POST

TRF-10

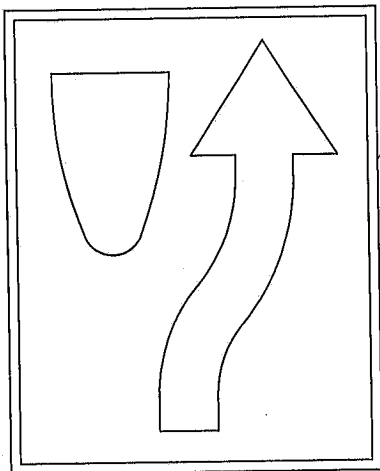

R4-7 KEEP RIGHT SIGN

OM1-1 SIGN

1.75", 12 GAUGE SQ. STEEL TUBING, PRE-GALVANIZED PERFORATED 7/16" DIAMETER HOLES AT 1" O.C. ON 4 SIDES

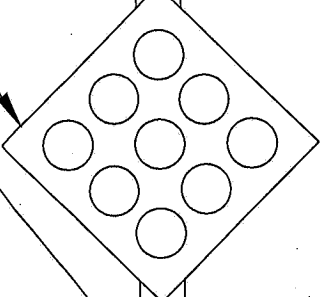

2" x 2" x 18" (MIN.) ANCHOR TO BE 36" WHEN NOT SET IN CONCRETE.

2 1/4" SQ. x 18" STIFFENER SLEEVE

RIVET 3/8"(D) x 19/32"(L)

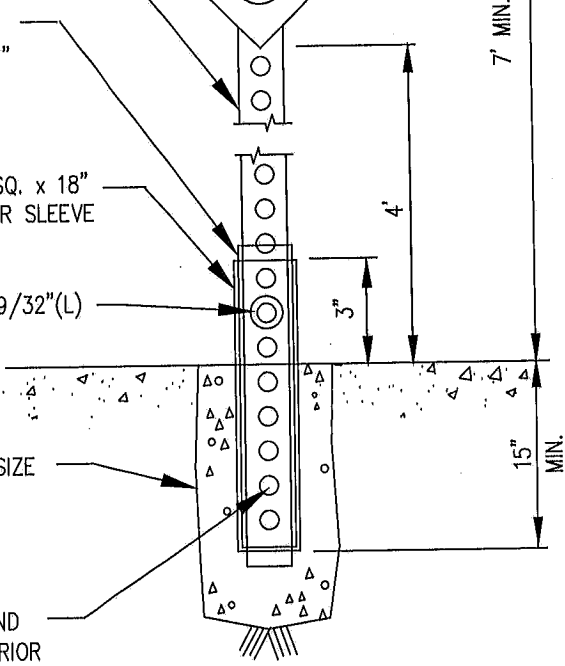

FOUNDATION SIZE 6" x 18" (MIN.)

TAPE HOLES AROUND POST ASSEMBLY PRIOR TO POURING CONCRETE.

NO SCALE

SHEET 2 OF 2

REVISION	BY	APPROVED	DATE	CITY OF CHULA VISTA ENGINEERING & CAPITAL PROJECTS STANDARD DRAWING	<i>William S. Valle</i> WILLIAM S. VALLE CITY ENGINEER
ORIGINAL	DPH	W. VALLE	11/17		
				BREAKAWAY POST ON MEDIAN	TRF-10

TYPICAL LADDER CROSSWALK MARKINGS

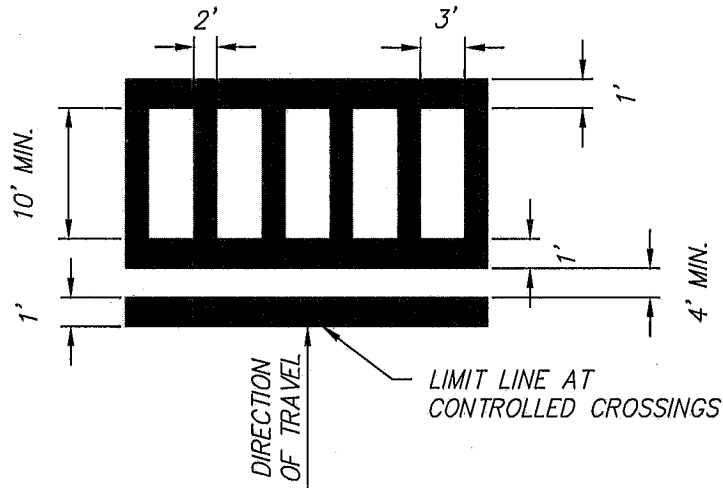

SINGLE RAMP CORNER

DUAL RAMP CORNER

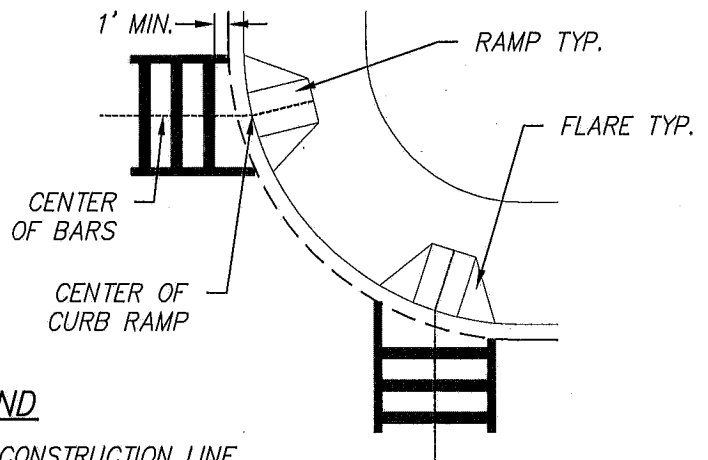
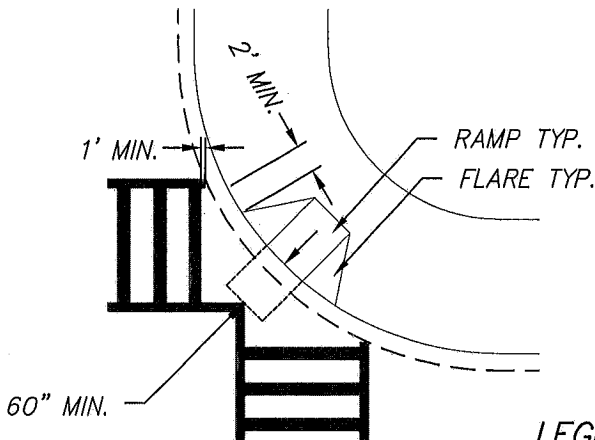

LEGEND

- CONSTRUCTION LINE
- ==== CURB & GUTTER
- CROSSWALK BAR (2' WIDE)

GENERAL NOTES:

1. MARKED CROSSWALKS SHALL BE WHITE OR YELLOW THERMOPLASTIC (AS REQUIRED) AND SHALL HAVE LADDER MARKINGS UNLESS APPROVED OTHERWISE.
2. MARKED CROSSWALK LOCATIONS CONSISTING OF BRICK PAVERS OR OTHER DECORATIVE PAVING SHALL BE PROVIDED WITH A LIMIT LINE ONLY.
3. SIGNALIZED INTERSECTIONS SHALL BE PROVIDED WITH A MARKED CROSSWALK ACROSS EACH LEG WHERE PEDESTRIANS ARE PERMITTED TO CROSS.
4. LONGITUDINAL LINES IN A LADDER CROSSWALK SHALL BE ANGLED PARALLEL TO THE DIRECTION OF VEHICULAR TRAVEL.
5. LIMIT LINES SHALL BE INSTALLED A MINIMUM OF 4 FEET IN ADVANCE OF MARKED CROSSWALKS FOR THE APPROACH LANES AT ALL CONTROLLED CROSSINGS.
6. MARKED CROSSWALKS SHOULD BE A MINIMUM OF 10 FEET IN WIDTH, PLACEMENT OF LADDER CROSSWALKS SHALL COMPLY WITH ACCESSIBILITY REGULATIONS PER THE MOST RECENT VERSION OF AMERICANS WITH DISABILITIES ACT (ADA) STANDARDS.
7. THE CROSSWALK BETWEEN A DUAL RAMP CORNER AND A SINGLE RAMP CORNER SHALL BE AT LEAST 10 FEET WIDE AND SATISFY THE MINIMUM OF 2 FEET BEYOND THE FLARE REQUIREMENT FOR THE SINGLE RAMP.
8. LADDER CROSSWALK BARS SHALL BE UNIFORM WITHIN THE SAME CROSSING. NO PARTIAL BARS SHALL BE INSTALLED.
9. A CROSSWALK BAR SHALL BE CENTERED IN THE CENTER OF THE CROSSING.
10. CROSSWALK MARKINGS SHALL BE CALIFORNIA MANUAL ON UNIFORM TRAFFIC CONTROL DEVICES (CA-MUTCO) RETROREFLECTIVITY COMPLIANT AND SKID RESISTANT.

REVISION	BY	APPROVED	DATE
ORIGINAL	DPH	W. VALLE	11/17

CITY OF CHULA VISTA
ENGINEERING & CAPITAL PROJECTS
STANDARD DRAWING

LADDER CROSSWALK MARKINGS
LAYOUTS AND NOTES

William S. Valle

WILLIAM S. VALLE 11/21/2017
CITY ENGINEER

TRF-11