

APPENDIX I
Geotechnical Investigation

**PRELIMINARY
GEO TECHNICAL INVESTIGATION**

**OTAY RANCH VILLAGE 4
CHULA VISTA, CALIFORNIA**



GEOCON
INCORPORATED

**GEO TECHNICAL
CONSULTANTS**

PREPARED FOR

**OTAY VALLEY QUARRY, LLC
% DUDEK
ENCINITAS, CALIFORNIA**

**MARCH 19, 2015
PROJECT NO. G1806-11-01**



Project No. G1806-11-01
March 19, 2015

Otay Valley Quarry, LLC
% Dudek
605 Third Street
Encinitas, California 92024

Attention: Mr. Brian Grover

Subject: PRELIMINARY GEOTECHNICAL INVESTIGATION
OTAY RANCH VILLAGE 4
CHULA VISTA CALIFORNIA

Dear Mr. Grover:

In accordance with authorization of our Proposal No. LG-14324 dated October 2, 2014, we herein submit the results of our preliminary geotechnical investigation for Otay Ranch Village 4 residential development. The accompanying report presents our findings, conclusions and recommendations pertaining to the geotechnical aspects of the proposed development. The study also includes an evaluation of the geologic units, geologic hazards, and rock rippability. Based on the results of this study, it is our opinion the site is considered suitable for development provided the recommendations of this report are followed.

Should you have any questions regarding this report, or if we may be of further service, please contact the undersigned at your convenience.

Very truly yours,

GEOCON INCORPORATED

John Hoobs
CEG 1524

Shawn Foy Weedon
GE 2714

JH:SFW:dmc

(e-mail) Addressee

TABLE OF CONTENTS

1.	PURPOSE AND SCOPE	1
2.	SITE AND PROJECT DESCRIPTION	2
3.	GEOLOGIC SETTING.....	3
4.	GEOLOGIC MATERIALS	3
4.1	General.....	3
4.2	Undocumented Fill (Qudf)	4
4.3	Topsoil/Colluvium (unmapped).....	4
4.4	Alluvium (Qal)	4
4.5	Landslide Debris (Qls).....	5
4.6	Terrace Deposits (Qt)	5
4.7	Otay Formation (To).....	5
4.8	Metavolcanic Rock (Mzu).....	5
5.	GEOLOGIC STRUCTURE	6
6.	GROUNDWATER	6
7.	GEOLOGIC HAZARDS	6
7.1	Seismic Hazard Analysis	6
7.2	Liquefaction.....	9
7.3	Expansive Soil	9
7.4	Landslides.....	9
7.5	Slope Stability.....	9
7.6	Tsunamis and Seiches.....	10
8.	ROCK RIPPABILITY	10
8.1	Seismic Refraction Surveys	10
8.2	Rippability of Metavolcanic Rock.....	11
8.3	Capping Material	12
9.	CONCLUSIONS AND RECOMMENDATIONS.....	13
9.1	General.....	13
9.2	Soil Characteristics	14
9.3	Seismic Design Criteria	16
9.4	Temporary Excavations	17
9.5	Slope Stability Analyses	18
9.6	Grading.....	19
9.7	Earthwork Grading Factors.....	23
9.8	Subdrains	23
9.9	Soil Creep and Lateral Fill Extension.....	25
9.10	Foundation and Concrete Slabs-On-Grade Recommendations	25
9.11	Exterior Concrete Flatwork	30
9.12	Conventional Retaining Wall Recommendations.....	31
9.13	Mechanically Stabilized Earth (MSE) Retaining Walls	32
9.14	Lateral Loads	35
9.15	Preliminary Pavement Recommendations.....	35
9.16	Site Drainage and Moisture Protection.....	38
9.17	Grading and Foundation Plan Review	40

TABLE OF CONTENTS (Concluded)

LIMITATIONS AND UNIFORMITY OF CONDITIONS

MAPS AND ILLUSTRATIONS

- Figure 1, Vicinity Map
- Figures 2 and 3, Geologic Maps (Map Pocket)
- Figures 4 and 5, Geologic Cross-Sections (Map Pocket)
- Figure 6, Typical Stability Fill Detail
- Figure 7, Typical Street Overexcavation Detail
- Figure 8, Oversize Rock Disposal Detail
- Figure 9, Typical Canyon Subdrain Detail
- Figure 10, Recommended Subdrain Cutoff Wall Detail
- Figure 11, Subdrain Outlet Headwall Detail
- Figure 12, Wall/Column Footing Dimension Detail
- Figure 13, Typical Retaining Wall Drain Detail

APPENDIX A

EXPLORATORY EXCAVATIONS

- Figures A-1 – A-20, Logs of Trenches

APPENDIX B

- SEISMIC REFRACTION SURVEY REPORT (Southwest Geophysics, 2015)

APPENDIX C

LABORATORY TESTING

- Table C-I, Summary of Laboratory Maximum Dry Density and Optimum Moisture Content Test Results
- Table C-II, Summary of Laboratory Direct Shear Test Results
- Table C-III, Summary of Laboratory Expansion Index Test Results
- Table C-IV, Summary of Laboratory Water-Soluble Sulfate Test Results
- Table C-V, Summary of Laboratory Water-Soluble Chloride Ion Content Test Results
- Table C-VI, Summary of Laboratory Resistance Value (R-Value) Test Results

APPENDIX D

SLOPE STABILITY ANALYSIS

- Table D-I, Summary of Soil Properties used for Slope Stability Analyses
- Table D-II, Summary of Slope Stability Analyses
- Figures D-1 – D-21, Computer Output from *GeoStudio2007*
- Figure D-22, Surficial Slope Stability Analysis

APPENDIX E

RECOMMENDED GRADING SPECIFICATIONS

LIST OF REFERENCES

PRELIMINARY GEOTECHNICAL INVESTIGATION

1. PURPOSE AND SCOPE

This report presents the results of our preliminary geotechnical investigation for the proposed Otay Ranch Village 4 residential development located in the City of Chula Vista, California (see Vicinity Map, Figure 1). The purpose of the investigation is to evaluate subsurface soil and geologic conditions at the site and, based on the conditions encountered, to provide recommendations pertaining to the geotechnical aspects of developing the property. The overall proposed residential development of Village 4 will include the construction of single- and multi-family residential neighborhoods with associated roadway and infrastructure improvements. An offsite sewer and access roadway extends to the southwest of the site and located west of the existing quarry. Plans for development are presented on the Geologic Map, Figures 2 and 3 (map pocket). We understand that Otay Ranch Village 4 will be developed in conjunction with the extension of Main Street.

The scope of our investigation included geologic mapping, subsurface exploration, laboratory testing, engineering analyses, and the preparation of this report. As a part of our investigation, we have reviewed aerial photographs, published geologic maps, published geologic reports, and previous geotechnical reports related to the property. A summary of the background information reviewed for this study is presented in the *List of References*.

Our field investigation included geologic mapping, the excavation of 20 trackhoe trenches, and performing 3 seismic refraction survey lines. Appendix A presents a discussion of the field investigation and logs of the trackhoe trenches. Appendix B summarizes the results of the seismic refraction surveys prepared by Southwest Geophysics. The approximate locations of the exploratory excavations and seismic surveys are presented on the Geologic Map (Figures 2 and 3). We performed laboratory tests on soil samples obtained from the exploratory excavations to evaluate pertinent physical and chemical properties for engineering analysis. The results of the laboratory testing are presented in Appendix C. We performed engineering analyses to evaluate the stability of the proposed slopes. The results of our slope stability analyses are discussed herein and also presented in Appendix D.

Hunsaker & Associates San Diego, Inc. provided the topographic information and proposed grading and development plans used during our field investigation and preparation of the Geologic Map. References to elevations presented in this report are based on the referenced topographic information. Geocon does not practice in the field of land surveying and is not responsible for the accuracy of such topographic information.

2. SITE AND PROJECT DESCRIPTION

The Otay Ranch Village 4 site is located within the southern portion of the City of Chula Vista, California. The site is located north of the active Vulcan Chula Vista Rock Quarry, east and south of Wolf Canyon, east of Otay Ranch Village 3 North, and west of Otay Ranch Village 8 West. Access will be provided by an approximate 2-mile eastern extension of Main Street.

The approximate 166-acre site is generally located on the northern flank of a ridgeline that slopes to the northwest toward Wolf Canyon which eventually flows south toward Otay River Drainage. Site elevations within the area of development range from approximately 150 feet above mean sea level (MSL) at the storm drain outlet and sewer tie-in at the southwestern corner of the site to approximately 610 feet MSL in the southeastern corner. The project area lies within the watershed of the Otay River, a westerly flowing stream that drains an area of approximately 145 square miles. Site vegetation consists of native grassland habitats and grasses.

We understand the planned development of Otay Ranch Village 4 consists of single- and multi-family residential neighborhoods with accommodating asphalt concrete roadways and utilities. Two single-family residential neighborhoods will be constructed consisting of 70 single-family lots at the south and east ends of the site accessed by public streets. The second neighborhood is located south of Main Street consisting of 111 single-family, alley loaded residential structures. A large sheet-graded pad will be graded on the north side of Main Street near the east portion of the site for a 215 unit, multi-family residential project yet to be designed. Proposed wet and dry utilities will be constructed within proposed roadways and alleys. A water quality basin with accommodating storm drain line and an offsite sewer main will be constructed south of Main Street on the southwest portion of the site. The proposed storm drain and sewer will extend approximately ½ mile southwest from Main Street. There are currently three sewer and storm drain alignment alternatives as shown on the Geologic Map, Figure 3. The alternatives will consist of a 25-foot wide easement road with graded slopes. Alternative “A” will traverse the edge of the Vulcan Quarry where existing end-dump piles approximately 60 feet in height are located. Construction of alternative “A” will require extensive remedial grading operations.

Grading will consist of cuts and fills of up to approximately 50 feet. Cut and fill slopes are planned to have maximum heights of approximately 90 feet, with a maximum slope inclination of 2:1 (horizontal to vertical). The proposed grading will require approximately 1.145 million cubic yards of excavation with roughly 65,600 cubic yards of export to balance the site.

The locations and descriptions provided herein are based on a site reconnaissance and review of the preliminary tentative map progress date March 3, 2015 and project information provided by the client and Hunsaker & Associates, San Diego.

3. GEOLOGIC SETTING

The site is located in the coastal plain of the Peninsular Ranges province of southern California. The Peninsular Ranges is a geologic and geomorphic province that extends from the Imperial Valley to the Pacific Ocean and from the Transverse Ranges to the north and into Baja California to the south. Crystalline basement rocks exist along the western side of the Peninsular Ranges and are dominated by pre-batholithic andesitic Metavolcanic Rock previously known as the Santiago Peak Volcanics with a late Jurassic and early Cretaceous age. The Metavolcanic Rock was intruded during the early to mid-Cretaceous by a variety of granitic to gabbroic plutons of the Southern California batholith. The coastal plain of San Diego County is underlain by a thick sequence of relatively undisturbed and non-conformable sedimentary rocks that range in age from Upper Cretaceous through the Pleistocene with intermittent deposition. In places, the outliers of metavolcanic and granitic rock protrude through the Tertiary sedimentary sequence to form resistant isolated hills. Geomorphically, the coastal plain is characterized by a stair stepped series of marine terraces which young to the west and have been dissected by west flowing rivers that drain the Peninsular Ranges to the east. The coastal plain is a relatively stable block that is dissected by relatively few faults consisting of the potentially active La Nacion Fault zone and the active Rose Canyon Fault Zone. The Peninsular Ranges is also dissected by the Elsinore Fault zone that is associated with and sub-parallel to the San Andreas Fault zone, which is the plate boundary between the Pacific and North American Plates.

The site is located on the central portion of the coastal plain and is in contact with a prominent hill composed of Metavolcanic Rock. The Metavolcanic Rock makes up the southeastern and eastern edge of the site. Marine sedimentary units unconformably overlie the Metavolcanic Rock, make up the northern and western portions of the site, and consist of the Tertiary age Otay Formation. The Otay Formation typically consists of three lithostratigraphic members composed of a basal conglomerate member, a middle gritstone member and an upper sandstone-claystone member with a maximum reported regional thickness of roughly 400 feet. The thickness of the Otay Formation varies at the site as it is underlain by the Metavolcanic Rock but generally increases to the west. The site has been dissected by a series of northwest trending canyons that have exposed the Otay Formation. Pleistocene-age Terrace Deposits are present on the northern flank of the Otay River.

4. GEOLOGIC MATERIALS

4.1 General

During our field investigation, we encountered four surficial deposits, consisting of undocumented fill, topsoil/colluvium, landslide debris, and alluvium. Three geologic units exist at the site consisting of Pleistocene-age Terrace Deposits, Tertiary-age Otay Formation and Jurassic- to Cretaceous-age Metavolcanic Rock. The lateral extent of the materials encountered is shown on the Geologic Map, Figures 2 and 3 (map pocket). Figures 4 and 5 (map pocket) present Geologic Cross-Sections providing an interpretation of the subsurface geologic conditions. The descriptions of the soil and

geologic conditions are shown on the trench logs located in Appendix A and described herein in order of increasing age.

4.2 Undocumented Fill (Qudf)

Based on field reconnaissance and review of previous geotechnical studies at the quarry site prepared by Geocon Incorporated (2006), undocumented fill soil is present in the form of a stockpile on the southwestern portion of the site attributed to the existing quarry. The stockpile is approximately 1,200 feet long in the north-south direction and approximately 300 to 500 feet wide in the east-west direction. The exposed western slope of the stockpile is approximately 50 to 60 feet high. The depth of the stockpile is unknown; however, the northeast side of the stockpile abuts native undisturbed grassland. Based on topographic maps, and original ground contours prior to mining activity, we estimate that the maximum depth of the stockpile is approximately 60 feet. The slope face appears to have reached its natural angle of repose and is inclined at approximately 1:1 (horizontal to vertical). Several hundred feet of the slope at the north end of the stockpile have been covered with “hydro-mulch.” The undocumented fill is compressible and removal will be necessary within the limits of grading in areas proposed to support compacted fill or structures.

4.3 Topsoil/Colluvium (unmapped)

Holocene-age topsoil/colluvium is present as a relatively thin veneer locally overlying formational materials across the site. The topsoil/colluvium has an average thickness of approximately 3 feet and can be characterized as soft to stiff and loose to medium dense, dry to damp, dark brown, sandy clay to clayey sand with gravel and cobble. The topsoil/colluvium is typically expansive and compressible. Removal of the topsoil will be necessary in areas to support proposed fill or structures. Due to the relatively thin thickness and discontinuity of these deposits, topsoil is not shown on the Geologic Map.

4.4 Alluvium (Qal)

Holocene-age alluvium is sheet-flow or stream deposited material found within the canyon drainages and generally vary in thickness dependent upon the size of the canyon and extent of the drainage area. The alluvium within the canyon drainages is loose to medium dense and can become saturated and difficult to excavate during the rainy season. Exploratory excavations within the alluvium areas were limited due to habitat restrictions but we expect the alluvium ranges up to approximately 8 feet within the limits of grading. Due to the relatively unconsolidated nature of these deposits, remedial grading will be necessary in areas to receive proposed fill or structures.

4.5 Landslide Debris (Qls)

Two landslides have been mapped and may exist approximately 800 feet north of the limits of development on the southern flank of Wolf Canyon as shown on Figure 2. The landslides are typically controlled by a basal bentonite claystone bed. The majority of the landslide debris is generated from the Otay Formation and likely consists of a mixture of sandstone, siltstone, and claystone fragments with local remolded clays, highly fractured and crushed zones, and soil and carbonate fracture infilling. The base of the landslide is typically sliding along the top of a bentonitic claystone layer that was undercut during erosion by the canyon drainage. The landslide is not located near proposed development and will not impact the project.

4.6 Terrace Deposits (Qt)

Pleistocene-age Terrace Deposits are deposited as shallow marine and non-marine near shore soil located on the southern corner of the site. We expect this unit will have a maximum thickness on the order of 15 to 20 feet. The Terrace Deposits are generally dense to very dense, reddish brown, silty to clayey sandstone with portions of the unit containing intermittent layers of cobbles and boulders up to about 2 feet in diameter. The Terrace Deposits is not located in an area of the planned development and we do not expect it will be encountered.

4.7 Otay Formation (To)

Tertiary-age Otay Formation is located along most of the northern and western portions of the site on the ridges and along the side slopes of canyon drainages. This unit consists of dense to very dense and hard, slightly and moderately cemented, clayey sandstone and sandy claystone with interbeds of gravel, cobble, and boulders up to 30 percent with a maximum dimension of approximately 10 inches. Excavations within this unit will generally be possible with heavy-duty grading equipment with moderate to heavy effort; however, cemented zones may create very difficult ripping and generate oversize cemented boulders. The Otay Formation is suitable for the support of proposed fill and structural loads. The sandstone portions of this unit are generally stable when excavated to construct cut slopes. The claystone layers may require slope stabilization in cut slopes, if encountered during grading operations. Slope drains may be necessary to intercept potential seepage on cut slopes created by landscape irrigation. The upper weathered portion of the Otay Formation (about 1 to 2 feet) will likely require remedial grading.

4.8 Metavolcanic Rock (Mzu)

Metavolcanic Rock is present within and north of the quarry site on the southeastern and northeastern portions of the site and generally varies from weak to strong, highly to slightly weathered. Highly weathered portions of the Metavolcanic Rock consist of highly expansive clay and soft rock. The highly weathered portion is generally rippable to depths varying from 2 to 10 feet deep with heavy-

duty grading equipment. The majority of this unit is moderately to slightly weathered and will generally be unrippable. Blasting will likely be required to excavate the hard rock portions of this unit and will generate oversize material. The Metavolcanic rock is generally suitable for the support of proposed fill and structural loads; however, the intensely weathered clayey upper portions of this unit will require remedial grading. Portion of this unit that generates rock when excavated is not suitable to cap streets and lots unless properly crushed. The Metavolcanic Rock is considered stable for construction of the proposed cut slopes if free of loose rock after blasting and excavation.

5. GEOLOGIC STRUCTURE

The geologic structure within the sedimentary units at the site is characterized by a gentle west to southwesterly dip. The contact between the sedimentary units and the underlying Metavolcanic Rock generally slopes down steeply to the west and north.

The geologic structure within the portions of the metavolcanic rock not subject to intense weathering is characterized as a hard rock mass displaying a relatively consistent, northwest-southeast trending foliation with dips generally averaging 50 degrees to the southwest and 50 degrees to the northeast (Geocon Inc., 2003). The dominant structural feature within the rock mass is jointing. Joints are surfaces, fractures or partings within a rock mass that do not show evidence of displacement. Jointing within the rock mass was formed as a result of regional tectonic stresses and joints generally have dips approximately 50 degrees. Geologic structure within the hard rock units is highly variable and should be evaluated for each proposed cut slope individually during grading operations.

6. GROUNDWATER

We did not encounter groundwater or seepage during our site investigation. However, it is not uncommon for seepage conditions to develop where none previously existed when sites are irrigated. Seepage is dependent on seasonal precipitation, irrigation, land use, among other factors, and varies as a result. Proper surface drainage will be important to future performance of the project. We expect groundwater is deeper than about 100 feet below existing grade. Perched groundwater may exist at or near the surface in the canyon about 300 feet to the north of the planned development. We do not expect groundwater or seepage to be encountered during construction of the proposed development.

7. GEOLOGIC HAZARDS

7.1 Seismic Hazard Analysis

It is our opinion, based on a review of published geologic maps and reports, that the site is not located on any known active, potentially active, or inactive fault traces. An active fault is defined by the California Geological Survey (CGS) as a fault showing evidence for activity within the last 11,000 years. The site is not located within a State of California Earthquake Special Study Zone.

According to the computer program *EZ-FRISK (Version 7.62)*, six known active faults are located within a search radius of 50 miles from the property. We used the 2008 USGS fault database that provides several models and combinations of fault data to evaluate the fault information. Based on this database, the Newport-Inglewood and Rose Canyon Fault Zones, located approximately 10 miles west of the site, are the nearest known active faults and are the dominant source of potential ground motion. Earthquakes that might occur on the Newport-Inglewood and Rose Canyon Fault Zones or other faults within the southern California and northern Baja California area are potential generators of significant ground motion at the site. The estimated maximum earthquake magnitude and peak ground acceleration for the Newport-Inglewood Fault are 7.5 and 0.28g, respectively. Table 7.1.1 lists the estimated maximum earthquake magnitude and peak ground acceleration for the most dominant faults in relation to the site location. We calculated peak ground acceleration (PGA) using Boore-Atkinson (2008) NGA USGS 2008, Campbell-Bozorgnia (2008) NGA USGS 2008, and Chiou-Youngs (2007) NGA USGS 2008 acceleration-attenuation relationships.

**TABLE 7.1.1
DETERMINISTIC SPECTRA SITE PARAMETERS**

Fault Name	Distance from Site (miles)	Maximum Earthquake Magnitude (Mw)	Peak Ground Acceleration		
			Boore-Atkinson 2008 (g)	Campbell-Bozorgnia 2008 (g)	Chiou-Youngs 2007 (g)
Newport-Inglewood	10	7.5	0.27	0.22	0.28
Rose Canyon	10	6.9	0.23	0.20	0.22
Coronado Bank	18	7.4	0.20	0.14	0.17
Palos Verde Connected	18	7.7	0.22	0.15	0.20
Elsinore	41	7.85	0.14	0.09	0.11
Earthquake Valley	45	6.8	0.08	0.06	0.05

In the event of a major earthquake on the referenced faults or other significant faults in the southern California and northern Baja California area, the site could be subjected to moderate to severe ground shaking. With respect to this hazard, the site is considered comparable to others in the general vicinity.

We performed a probabilistic seismic hazard analysis using the computer program *EZ-FRISK*. Geologic parameters not addressed in the deterministic analysis are included in this analysis. The program operates under the assumption that the occurrence rate of earthquakes on each mapped Quaternary fault is proportional to the faults slip rate. The program accounts for fault rupture length as a function of earthquake magnitude, and site acceleration estimates are made using the earthquake magnitude and distance from the site to the rupture zone. The program also accounts for uncertainty

in each of following: (1) earthquake magnitude, (2) rupture length for a given magnitude, (3) location of the rupture zone, (4) maximum possible magnitude of a given earthquake, and (5) acceleration at the site from a given earthquake along each fault. By calculating the expected accelerations from considered earthquake sources, the program calculates the total average annual expected number of occurrences of site acceleration greater than a specified value. We utilized acceleration-attenuation relationships suggested by Boore-Atkinson (2008) NGA USGS 2008, Campbell-Bozorgnia (2008) NGA USGS 2008, and Chiou-Youngs (2007) NGA USGS 2008 in the analysis. Table 7.1.2 presents the site-specific probabilistic seismic hazard parameters including acceleration-attenuation relationships and the probability of exceedence.

**TABLE 7.1.2
PROBABILISTIC SEISMIC HAZARD PARAMETERS**

Probability of Exceedence	Peak Ground Acceleration		
	Boore-Atkinson, 2008 (g)	Campbell-Bozorgnia, 2008 (g)	Chiou-Youngs, 2007 (g)
2% in a 50 Year Period	0.43	0.35	0.41
5% in a 50 Year Period	0.31	0.26	0.29
10% in a 50 Year Period	0.24	0.20	0.21

The California Geologic Survey (CGS) has a program that calculates the ground motion for a 10 percent of probability of exceedence in a 50-year period based on an average of several attenuation relationships. Table 7.1.3 presents the calculated results from the Probabilistic Seismic Hazards Mapping Ground Motion Page from the CGS website.

**TABLE 7.1.3
PROBABILISTIC SITE PARAMETERS FOR SELECTED FAULTS
CALIFORNIA GEOLOGIC SURVEY**

Calculated Acceleration (g) Firm Rock	Calculated Acceleration (g) Soft Rock	Calculated Acceleration (g) Alluvium
0.22	0.24	0.28

While listing peak accelerations is useful for comparison of potential effects of fault activity in a region, other considerations are important in seismic design, including the frequency and duration of motion and the soil conditions underlying the site. Seismic design of the structures should be performed in accordance with the 2013 California Building Code (CBC) guidelines currently adopted by the County of San Diego.

7.2 Liquefaction

Liquefaction typically occurs when a site is located in a zone with seismic activity, onsite soils are cohesionless, static groundwater is encountered within 50 feet of the surface, and soil relative densities are less than about 70 percent. If the four previous criteria are met, a seismic event could result in a rapid pore-water pressure increase from the earthquake-generated ground accelerations. Seismically induced settlement may occur whether the potential for liquefaction exists or not. The potential for liquefaction and seismically induced settlement occurring within the site soil is considered to be very low due to the dense nature of proposed fill, the very dense nature of the formational materials, and the lack of a permanent groundwater table within the upper 50 feet of the planned finish grade elevations. .

7.3 Expansive Soil

The majority of the geologic units will likely possess a “very low” to “medium” expansion potential (Expansion Index of 90 or less). However, some of the geologic units contain a “high” expansive potential (Expansion Index of 91 to 130). These units can include topsoil and colluvium and the claystone beds within the Otay Formation, and the highly weathered clays of the Metavolcanic Rock. If highly expansive clays and claystone beds are exposed near finish grade, undercutting of lots, streets, curb and gutters, and sidewalk subgrade will be required. Stability fills may also be required if claystone beds within the Otay Formation are exposed in cut slopes.

7.4 Landslides

Examination of stereoscopic aerial photographs in our files, our geologic reconnaissance, and review of available geotechnical and geologic reports for the site vicinity indicate that landslides are not present at a location that could impact the site. The northwest portion contains a small landslide that is within Wolf Canyon about 800 feet from the limits of development. We do not consider landsliding to be a geologic hazard to the project.

7.5 Slope Stability

We evaluated the proposed slope configurations, as depicted on the Geologic Map, to evaluate both surficial and global stability based on the current geologic information. The portions of the site planned for development are generally underlain by Quaternary-age surficial soil, Tertiary-age Otay Formation and Jurassic- to Cretaceous-age Metavolcanic Rock. The units most likely to be subject to slope instability are the slopes above the claystone portion of the Otay Formation. The stability of graded slopes composed of Metavolcanic Rock is highly dependent on the degree of weathering and the geologic structure of the slope face. Slope stability analyses using the two-dimensional computer program *GeoStudio2007* created by Geo-Slope International Ltd. are presented in Appendix D. The

proposed slopes should be stable from shallow sloughing conditions provided the recommendations for grading and drainage are incorporated into the design and construction of the proposed slopes.

In general, it is our opinion that permanent, graded fill slopes or cut slopes excavated within the Otay Formation with gradients of 2:1 (horizontal to vertical) or flatter will possess Factors of Safety of 1.5 or greater. However, stability fill construction may be required during grading operations if claystone beds are encountered within the Otay Formation on proposed cut slopes. The majority of rock cut slopes should be comprised of *good quality* (Hoek and Bray, 1981), moderately strong to very strong Metavolcanic Rock. Based on the results of our slope stability analyses, slopes composed of moderately to slightly weathered rock should possess Factors of Safety of 1.5 or greater against large-scale, deep-seated slope failures at their present and proposed slope inclinations.

Because of the potential presence of adverse geologic jointing, the geologic structure of permanent cut slopes composed of Metavolcanic Rock should be analyzed in detail by an engineering geologist during the grading operations. Additional recommendations for slope stabilization may be necessary if adverse geologic structure is encountered. Grading of cut and fill slopes should be designed in accordance with the requirements of the local building codes or the 2013 California Building Code (CBC). Mitigation of unstable cut slopes can be achieved by the use of drained stability fills.

7.6 Tsunamis and Seiches

A tsunami is a series of long period waves generated in the ocean by a sudden displacement of large volumes of water. Causes of tsunamis include underwater earthquakes, volcanic eruptions, or offshore slope failures. The site is approximately 8 miles from the Pacific Coast and ranges between approximately 150 feet to 610 above MSL. Therefore, we consider the risk associated with tsunamis to be negligible.

A seiche is a run-up of water within a lake or embayment triggered by fault- or landslide-induced ground displacement. Large bodies of water are not adjacent to the site. Therefore, the potential of seiches affecting the site is considered negligible.

8. ROCK RIPPABILITY

8.1 Seismic Refraction Surveys

Southwest Geophysics performed a seismic refraction survey to evaluate the rippability of the Metavolcanic Rock along 3 seismic lines. The locations of the seismic traverses are presented on the Geologic Map, Figure 2 with their report presented in Appendix B.

Based on our experience, we have summarized the estimated rippability characteristics for various excavation methods related to seismic velocity in Table 8.1. Estimates for mass grading rippability are based on using a D-9 Caterpillar Tractor equipped with a single shank hydraulic ripper. Estimates for trenching rippability are based on using a Caterpillar 345 excavator. It is often found to be more cost effective to blast marginally rippable rock.

**TABLE 8.1
SUMMARY OF ESTIMATED RIPPABILITY FROM SEISMIC REFRACTION**

Excavation Method	Seismic Velocity (ft/s)	Estimated Rippability
Mass Grading	Less than 4,000	Rippable
	4,000 to 5,500	Marginal Ripping (Possible Blasting)
	Greater than 5,500	Non-Rippable (Pre-Blasting Required)
Trenching	Less than 3,500	Rippable
	3,500 to 4,000	Marginal Ripping
	Greater than 4,000	Non-Rippable

The results of the seismic refraction surveys indicate that velocities less than approximately 3,000 ft/s are likely associated with surficial soil and highly weathered rock. Velocities between 3,000 and 5,000 ft/s are likely associated with sedimentary units and moderately weathered rock. Velocities between 5,000 and 7,000 ft/s are likely associated with slightly weathered rock, with higher velocities associated with unweathered rock. Rippability is highly dependent upon the degree of weathering, fracturing, and jointing within the rock mass and the rippability of the various soil and rock units is, correspondingly, variable.

8.2 Rippability of Metavolcanic Rock

We excavated exploratory trenches and performed seismic traverses in the Metavolcanic Rock unit (Mzu), located generally in proposed cut areas in the southeast portion of the site, to evaluate rock rippability characteristics. The rippability of this rock unit is variable, and is generally limited to the depth of the weathered mantle. Proposed excavations within the Metamorphic Rock will require very difficult ripping and blasting as excavations extend beyond the rippable weathered mantle. Using a seismic shear wave velocity of 5,500 ft/s as a limit, we estimate the thickness of the rippable rock mantle varies between 2 to 10 feet.

Heavy ripping and/or blasting should also be expected in areas of concentrated surface rock outcroppings. Estimates of the expected volume of hard rock and rock aggregate quality materials generated from proposed excavations should be evaluated based on the information from the seismic refraction survey. Roadway/utility corridor and lot undercutting criteria should also be considered

when calculating the volume of hard rock. Proposed cuts in hard rock areas can be expected to generate oversized fragments (rocks greater than 12 inches in dimension) which will necessitate typical rock handling and placement procedures during grading operations. The grading contractor should perform an additional investigation to observe the rippability characteristics for estimating purposes.

8.3 Capping Material

Capping material refers to select material placed within 3 feet from building pad grade, 8 feet from roadway grade, and to at least 1 foot below the deepest utility within roadways. The capping material should consist of “soil” fill with an approximate maximum particle dimension of 6 inches with a minimum of 40 percent soil passing the ¾-inch sieve. In addition, the upper 3 feet of finish pad grade should have at least 20 percent of the soil passing the No. 4 screen and have an expansion index of 90 or less. In general, capping material can be readily obtained from the sandstone portions of the Otay Formation.

9. CONCLUSIONS AND RECOMMENDATIONS

9.1 General

- 9.1.1 It is our opinion that no soil or geologic conditions were encountered during the investigation that would preclude the proposed development of the Otay Ranch Village 4 project provided the recommendations presented herein are followed and implemented during construction.
- 9.1.2 Potential geologic hazards at the site include seismic shaking and expansive and compressible soil. Based on our investigation and available geologic information, active, potentially active; or inactive faults are not present underlying or trending toward the site.
- 9.1.3 The existing onsite surficial soil units including undocumented fill, topsoil/colluvium, alluvium, and highly weathered formational materials are potentially compressible and unsuitable in their present condition for the support of compacted fill or settlement-sensitive improvements. Remedial grading of the surficial soil and highly weathered formational materials will be required and recommendations for remedial grading are provided herein. The strong Metavolcanic Rock and dense portions of the Otay Formation are suitable for the support of proposed fill and structural loads.
- 9.1.4 We did not encounter groundwater during our subsurface exploration and we do not expect it to be a constraint to project development. However, seepage within formational materials and perched groundwater conditions within the canyon drainages may be encountered during the grading operations, especially during the rainy seasons.
- 9.1.5 The rippability of the surficial units is expected to range from easy to moderate. We expect the Otay Formation to be rippable with moderate to heavy effort to proposed finish grades. Cemented zones should be expected within portions of the Otay Formation. These will generate oversized material during grading. The rippability of the Metavolcanic Rock is variable and ranges between moderate to very difficult with refusal expected. Rock breaking and blasting should be expected during grading within the Metavolcanic Rock.
- 9.1.6 In general, cut slopes composed of Metavolcanic Rock and Otay Formation should possess Factors of Safety at least 1.5 at inclinations of 2:1 (horizontal to vertical), or flatter. The geologic structure of cut slopes composed of hard rock should be evaluated during grading operations by the geotechnical consultant.

- 9.1.7 Proposed cut slopes that expose claystone within the Otay Formation will require slope stabilization. Recommendations for stabilization of potentially unstable slopes consisting of stability fills are discussed herein.
- 9.1.8 The proposed residential structures and site retaining walls may be supported on conventional foundations bearing in either competent formational materials or properly compacted fill. Transitioning building foundations and slabs from bedrock to compacted fill should not occur. Where fill will be utilized for building foundation support, the foundation system for the entire structure should be underlain by properly compacted fill. Bedrock over-excavations will be required where engineered fill is to be utilized for foundation support. General recommendations for the design of shallow foundations are provided herein.
- 9.1.9 Due to the existence of hard rock at or near the proposed grades at the southeast portions of the site, the building pads, streets, and utility corridors underlain by Metavolcanic Rock should be over excavated to facilitate future excavation of footings, subgrade, and utility trenches. Recommendations for over-excavation operations are provided herein.
- 9.1.10 Proper drainage should be maintained in order to preserve the engineering properties of the fill in both the building pads and slope areas. Recommendations for site drainage are provided herein.

9.2 Soil Characteristics

- 9.2.1 The soil encountered in the field investigation is generally considered to be “expansive” (Expansion Index [EI] greater than 20) as defined by 2013 California Building Code (CBC) Section 1803.5.3. Table 9.2.1 presents soil classifications based on the expansion index.

**TABLE 9.2.1
SOIL CLASSIFICATION BASED ON EXPANSION INDEX**

Expansion Index (EI)	Expansion Classification	2013 CBC Expansion Classification
0 – 20	Very Low	Non-Expansive
21 – 50	Low	Expansive
51 – 90	Medium	
91 – 130	High	
Greater Than 130	Very High	

9.2.2 Based on laboratory tests of representative samples of the materials expected at proposed grades presented in Appendix C, the on-site material is expected to possess a “very low” to “high” expansion potential (Expansion Index of 130 or less). We expect the surficial soil and the claystone portions of the Otay Formation and highly weathered clay of the Metavolcanic Rock will likely possess a “medium” to “very high” expansion potential (Expansion Index greater than 50). The sandstone portions of the Otay Formation and unweathered portions of the Metavolcanic Rock will likely possess a “very low” to “low” expansion potential (Expansion Index of 50 or less). Additional testing for expansion potential should be performed once final grades are achieved.

9.2.3 We performed laboratory tests on samples of the site materials to evaluate the percentage of water-soluble sulfate content. Results from the laboratory water-soluble sulfate content tests are presented in Appendix C (Table C-IV) and indicate that the on-site materials at the locations tested possess “not applicable” (S0) sulfate exposure to concrete structures as defined by 2013 CBC Section 1904 and ACI 318-11 Sections 4.2 and 4.3. Table 9.2.2 presents a summary of concrete requirements set forth by 2013 CBC Section 1904 and ACI 318. The presence of water-soluble sulfates is not a visually discernible characteristic; therefore, other soil samples from the site could yield different concentrations. Additionally, over time landscaping activities (i.e., addition of fertilizers and other soil nutrients) may affect the concentration.

**TABLE 9.2.2
REQUIREMENTS FOR CONCRETE EXPOSED TO
SULFATE-CONTAINING SOLUTIONS**

Sulfate Severity	Exposure Class	Water-Soluble Sulfate (SO₄) Percent by Weight	Cement Type (ASTM C 150)	Maximum Water to Cement Ratio by Weight	Minimum Compressive Strength (psi)
Not Applicable	S0	SO ₄ <0.10	--	--	2,500
Moderate	S1	0.10 ≤ SO ₄ < 0.20	II	0.50	4,000
Severe	S2	0.20 ≤ SO ₄ ≤ 2.00	V	0.45	4,500
Very Severe	S3	SO ₄ > 2.00	V+Pozzolan or Slag	0.45	4,500

9.2.4 We performed laboratory tests on a sample of the site materials encountered to check the corrosion potential to subsurface metal structures. We performed the laboratory tests in accordance with California Test Method No. 643. In addition, we performed a laboratory

test to check the water-soluble chloride ion content in accordance with AASHTO Test No. T 291. The laboratory test results are presented in Appendix C.

- 9.2.5 Geocon Incorporated does not practice in the field of corrosion engineering. Therefore, further evaluation by a corrosion engineer may be performed if improvements that could be susceptible to corrosion are planned.

9.3 Seismic Design Criteria

- 9.3.1 We used the computer program *U.S. Seismic Design Maps*, provided by the USGS. Table 9.3.1 summarizes site-specific design criteria obtained from the 2013 California Building Code (CBC; Based on the 2012 International Building Code [IBC] and ASCE 7-10), Chapter 16 Structural Design Section 1613 Earthquake Loads. The short spectral response uses a period of 0.2 second. The structures should be designed using Site Class C where there is less than 20 feet of fill and Site Class D where the fill thickness is 20 feet or greater. We evaluated the Site Class based on the discussion in Section 1613.3.2 of the 2013 CBC and Table 20.3-1 of ASCE 7-10. The values presented in Table 9.3.1 are for the risk-targeted maximum considered earthquake (MCE_R). We will evaluate the structure site class for each building once the final grading has been completed.

**TABLE 9.3.1
2013 CBC SEISMIC DESIGN PARAMETERS**

Parameter	Value		2013 CBC Reference
	C	D	
Site Class	C	D	Section 1613.3.2
MCE_R Ground Motion Spectral Response Acceleration – Class B (short), S_S	0.835g	0.835g	Figure 1613.3.1(1)
MCE_R Ground Motion Spectral Response Acceleration – Class B (1 sec), S_1	0.321g	0.321g	Figure 1613.3.1(2)
Site Coefficient, F_A	1.066	1.166	Table 1613.3.3(1)
Site Coefficient, F_V	1.479	1.759	Table 1613.3.3(2)
Site Class Modified MCE_R Spectral Response Acceleration (short), S_{MS}	0.890g	0.974g	Section 1613.3.3 (Eqn 16-37)
Site Class Modified MCE_R Spectral Response Acceleration (1 sec), S_{M1}	0.474g	0.564g	Section 1613.3.3 (Eqn 16-38)
5% Damped Design Spectral Response Acceleration (short), S_{DS}	0.594g	0.649g	Section 1613.3.4 (Eqn 16-39)
5% Damped Design Spectral Response Acceleration (1 sec), S_{D1}	0.316g	0.376g	Section 1613.3.4 (Eqn 16-40)

9.3.2 Table 9.3.2 presents additional seismic design parameters for projects located in Seismic Design Categories of D through F in accordance with ASCE 7-10 for the mapped maximum considered geometric mean (MCE_G).

**TABLE 9.3.2
2013 CBC SITE ACCELERATION DESIGN PARAMETERS**

Parameter	Value		ASCE 7-10 Reference
	C	D	
Site Class	C	D	Section 1613.3.2 (2013 CBC)
Mapped MCE_G Peak Ground Acceleration, PGA	0.328g	0.328g	Figure 22-7
Site Coefficient, F_{PGA}	1.072	1.172	Table 11.8-1
Site Class Modified MCE_G Peak Ground Acceleration, PGA_M	0.351g	0.384g	Section 11.8.3 (Eqn 11.8-1)

9.3.3 Conformance to the criteria in Tables 9.3.1 and 9.3.2 for seismic design does not constitute any kind of guarantee or assurance that significant structural damage or ground failure will not occur if a large earthquake occurs. The primary goal of seismic design is to protect life, not to avoid all damage, since such design may be economically prohibitive.

9.4 Temporary Excavations

9.4.1 The recommendations included herein are provided for stable excavations. It is the responsibility of the contractor to provide a safe excavation during the construction of the proposed project.

9.4.2 Temporary slopes should be made in conformance with OSHA requirements. The surficial soil should be considered a Type C soil, compacted fill should be considered a Type B soil (Type C if seepage is encountered), and the formational materials should be considered a Type A soil (Type B soil if seepage or groundwater is encountered) in accordance with OSHA requirements. In general, special shoring requirements will not be necessary if temporary excavations will be less than 4 feet in height. Temporary excavations greater than 4 feet in height, however, should be sloped back at an appropriate inclination. These excavations should not be allowed to become saturated or to dry out. Surcharge loads should not be permitted to a distance equal to the height of the excavation from the top of the excavation. The top of the excavation should be a minimum of 15 feet from the edge of existing improvements. Excavations steeper than those recommended or closer than 15 feet from an existing surface improvement should be shored in accordance with applicable OSHA codes and regulations.

9.5 Slope Stability Analyses

- 9.5.1 We performed the slope stability analyses using the computer software program *GeoStudio2007*, to calculate the factor of safety with respect to deep-seated stability. This program uses conventional slope stability equations and a two-dimensional, limit-equilibrium method. We performed the rotational-mode and block-mode analyses using Spencer's method. Output of the computer program including the calculated Factor of Safety and the failure surface is shown on Figures D-1 through D-21 in Appendix D.
- 9.5.2 Slope stability analyses utilizing average drained direct shear strength parameters based on laboratory tests and our experience with similar soil types in nearby areas indicates that the proposed cut and fill slopes within the planned development, constructed of on-site materials, should have calculated factors of safety of at least 1.5 under static conditions for both deep-seated failure and shallow sloughing conditions if the recommendations of this report are followed. Table D-I in Appendix D presents the shear strength parameters used in the slope stability analyses.
- 9.5.3 We selected Cross-Sections A-A', B-B', C-C', D-D', and E-E' (Figures 4 and 5) to perform the slope stability analyses. The results and the computer output of the analyses are presented in Appendix D. Table D-II provides a description of the cross-sections, their corresponding factor of safety, and the condition of the slope stability analyses. A factor of safety of 1.5 for static conditions is currently required by the City of Chula Vista for permanent graded slopes.
- 9.5.4 Some of the existing native descending slopes possess factors of safety of less than 1.5. However, the factor of safety of the planned slopes within the development possess calculated factors of safety of at least 1.5. Therefore, we do not expect buttressing and remedial grading outside of the planned development is required for slope stability purposes.
- 9.5.5 If claystone layers are exposed on cut slopes within the Otay Formation, the construction of a stability fill will be required to stabilize the slope face. Figure 6 presents a typical stability fill detail.
- 9.5.6 We performed surficial slope stability calculations for a 2:1 (horizontal to vertical) slope in compacted fill. The calculated factor of safety is greater than the required minimum factor of safety of 1.5. Plants with variable root depth should be planted as soon as practical once the fill slopes have been constructed. Surficial slope stability calculations are presented on Figure D-22 in Appendix D.

9.5.7 Stability fill drains should be surveyed during construction and depicted on the As-Graded Geologic Map in the final report of grading.

9.5.8 Excavations including cut slopes, shear keys and stability fills should be observed during grading by an engineering geologist to check whether soil and geologic conditions differ significantly from those expected.

9.6 Grading

9.6.1 Grading should be performed in accordance with the *Recommended Grading Specifications* contained in Appendix E and the City of Chula Vista Grading Ordinance.

9.6.2 Prior to commencing grading, a preconstruction conference should be held at the site with the county inspector, owner or developer, grading contractor, civil engineer, environmental consultant, and geotechnical engineer in attendance. Special soil handling and/or the grading plans can be discussed at that time.

9.6.3 Site preparation should begin with the removal of deleterious material, debris and vegetation. The depth of removal should be such that material exposed in cut areas or soil to be used as fill is relatively free of organic matter. Material generated during stripping and/or site demolition should be exported from the site.

9.6.4 Abandoned foundations and buried utilities (if encountered) should be removed and the resultant depressions and/or trenches should be filled with properly compacted material as part of the remedial grading.

9.6.5 Topsoil/colluvium, alluvium, undocumented fill, and highly weathered portions of the Otay Formation and Metavolcanic Rock within the limits of grading should be removed to expose firm formational materials. The actual depth of removal should be evaluated by the geotechnical engineering consultant during the grading operations. The bottom of the excavations should be scarified to a depth of at least 12 inches (where possible); moisture conditioned as necessary, and properly compacted. Excavated soil with an Expansion Index greater than 90 should be kept at least 3 feet below finish grade. The sheet-graded pad should be capped with at least 6 feet of fill soil that possesses a “very low” to “medium” expansion potential (EI of 90 or less) to accommodate future pad regrading, where possible.

9.6.6 If perched groundwater is encountered during remedial grading within the surficial soil, top loading of wet material may be required. This condition may potentially occur within the

canyon drainages, especially during the rainy season. The excavated materials should then be moisture conditioned as necessary to near optimum moisture content prior to placement as compacted fill.

- 9.6.7 The geotechnical engineering consultant should observe the removal bottoms to check the exposure of the formational materials. Deeper excavations may be required if highly weathered formational materials are present at the base of the removals.
- 9.6.8 The site should be brought to final finish grade elevations with structural fill compacted in layers. Layers of fill should be no thicker than will allow for adequate bonding and compaction. Fill, including backfill and scarified ground surfaces, should be compacted to a dry density of at least 90 percent of the laboratory maximum dry density near to slightly above optimum moisture content in accordance with ASTM D 1557. Fill placed in excess of 50 feet from finish grade should be compacted to a dry density of at least 92 percent of the laboratory maximum dry density near to slightly above optimum moisture content. Fill materials placed below optimum moisture content may require additional moisture conditioning prior to placing additional fill.
- 9.6.9 To reduce the potential for differential settlement, the building pads with cut-fill transitions should be undercut at least 3 feet, sloped 1 percent to the adjacent street or deepest fill, and replaced with properly compacted fill with a “very low” to “medium” expansion potential (EI of 90 or less). Where the thickness of the fill below the building pad exceeds 15 feet, the depth of the undercut for cut-fill transition lots, should be increased to one-fifth of the maximum fill thickness to a maximum depth of 10 feet.
- 9.6.10 The City of Chula Vista has required that the upper 5 feet of fill soil and the upper 3 feet of formational materials within the public right-of-way or public easement possess an expansion index of 90 or less. If material with an expansion index greater than 90 exists within the right-of-ways, the upper 5 feet of compacted fills and the upper 3 feet of formational should be removed and replaced with fill with an expansion index of 90 or less or an alternative method should be approved by the City of Chula Vista.
- 9.6.11 Building pads underlain by hard rock units at grade should also be undercut to facilitate future trenching. Building pads that expose hard rock should be undercut a minimum of 3 feet and replaced with properly compacted fill and the base of the undercut should be sloped a minimum of 1 percent toward the adjacent street. In addition, consideration should be given to undercutting building pads exposing the Otay Formation due to very dense materials.

9.6.12 Roadways underlain by hard rock should be undercut a minimum of 8 feet for the areas inside of the public right-of-way (including joint utility structures and sidewalk areas). The undercut zone should include the areas at least 1 foot below the lowest utility or drain line. Figure 7 presents a typical detail for the over-excavation of streets.

9.6.13 Recommendations for the handling and disposal of oversized rock in fill areas are presented in Figure 8 and in Appendix E. In general, structural fill placed and compacted at the site should consist of material that can be classified into four zones:

Zone A: Material placed within 3 feet from building pad grade, 8 feet from roadway grade, and to at least 1 foot below the deepest utility within roadways should consist of “soil” fill with an approximate maximum particle dimension of 6 inches with a minimum of 40 percent of the soil passing the ¾-inch sieve. In addition, the upper 3 feet of pad grade should have at least 20 percent of the soil passing the No. 4 sieve.

Zone B: Material placed below 8 feet from grade (below Zone A and C) may consist of “rock” fill or “soil/rock” fill (as defined in Appendix E). Blasted rock should generally consist of 2 foot minus rock material with occasional rock up to 4 foot in maximum dimension. Alternatively, “soil” fill may be placed in Zone B containing rock with a maximum dimension of 2 feet. Rocks up to 4 feet in maximum dimension can be individually placed in a properly compacted soil matrix with rocks separated at least 8 feet apart.

Zone C: Within 3 to 8 feet of pad grade and between 5 and 15 feet from face of slope, fill material should consist of “soil” fill with an approximate maximum particle dimension of 1 foot. Rocks up to 2 feet in maximum dimension may be placed, provided they are distributed in a matrix of compacted “soil” fill.

Zone D: Within the outer 5 feet of fill slopes, the fill should consist of rock up to 1 foot in maximum dimension in a matrix of compacted “soil” fill.

9.6.14 Import fill (if necessary) should consist of granular materials with a “very low” to “low” expansion potential (EI of 50 or less) generally free of deleterious material and rock fragments larger than 6 inches in maximum size if used for capping and should be compacted as recommended herein. Geocon Incorporated should be notified of the import soil source and should perform laboratory testing of import soil prior to its arrival at the site to evaluate its suitability as fill material.

9.6.15 Cut slopes that expose weak and/or sheared claystone beds may require stability fills as evaluated by the engineering geologist. In addition, cut slopes exposing cohesionless surficial deposits or rock slopes with unfavorable geologic structure may require stability

fills. In general, the Typical Stability Fill Detail presented on Figure 6 should be used for design and construction of stability fills, where required. The backcut for the stability fills should commence at least 10 feet from the top of the proposed finish-graded slope and should extend at least 3 feet into formational materials. For slopes that exceed 30 feet in height, the inclination of the backcut may be flattened as determined by the engineering geologist during grading operations.

- 9.6.16 Cut slope excavations including fill slope shear keys should be observed during grading operations to check that soil and geologic conditions do not differ significantly from those expected. Cut slopes excavated in Metavolcanic Rock will need to be scaled of loose rock.
- 9.6.17 The outer 15 feet (or a distance equal to the height of the slope, whichever is less) of fill slopes should be composed of properly compacted granular “soil” fill to reduce the potential for surficial sloughing. In general, soil with an Expansion Index of 90 or less and at least 35 percent sand-size particles should be acceptable as “soil” fill. Soil of questionable strength to satisfy surficial stability should be tested in the laboratory for acceptable drained shear strength. The use of cohesionless soil in the outer portion of fill slopes should be avoided. Fill slopes should be overbuilt at least 2 feet and cut back or be compacted by backrolling with a loaded sheepsfoot roller at vertical intervals not to exceed 4 feet to maintain the moisture content of the fill. The slopes should be track-walked at the completion of each slope such that the fill is compacted to a dry density of at least 90 percent of the laboratory maximum dry density near to slightly above optimum moisture content to the face of the finished slope.
- 9.6.18 Placement of rock fills should be planned in the deeper fill areas to facilitate rock disposal. Overexcavation of fill areas may be required to accommodate the necessary rock volumes generated during blasting. Capping material used for placement near finish grade within roadways, building pads, and slope zones should be stockpiled during excavation and remedial grading operations. Overexcavation of units that generate capping material may be necessary to achieve sufficient volumes to achieve finish grade.
- 9.6.19 Rock fill placement should be performed in accordance with the Recommended Grading Specifications provided in Appendix E. Blasting of rock material should be performed to maximize rock breakage to 2-foot minus material. Rock fill placement should generally be limited to 2-foot-thick horizontal layers and compacted using rock trucks and bulldozers. Significant volumes of water are typically required during rock fill placement. The downstream areas can generate large volumes of water that can be re-used during construction.

9.6.20 Finished slopes should be landscaped with drought-tolerant vegetation having variable root depths and requiring minimal landscape irrigation. In addition, the slopes should be drained and properly maintained to reduce erosion.

9.7 Earthwork Grading Factors

9.7.1 Estimates of bulking and shrinkage factors are based on empirical judgments comparing the material in its natural state as encountered in the exploratory excavations to a compacted state. Variations in natural soil density and in compacted fill density render shrinkage value estimates very approximate. As an example, the contractor can compact the fill to a dry density of 90 percent or higher of the laboratory maximum dry density. Thus, the contractor has an approximately 10 percent range of control over the fill volume. Bulking of rock units is a function of rock density, structure, overburden pressure, and the physical behavior of blasted material. Based on our experience, the shrinkage and bulking factors presented in Table 9.7 can be used as a basis for estimating how much the on-site soil may shrink or swell (bulk) when excavated from their natural state and placed as compacted fill. Please note that these estimates are for preliminary quantity estimates only. Due to the variations in the actual shrinkage/bulking factors, a balance area that can also accommodate rock should be provided to accommodate these variations.

**TABLE 9.7
SHRINKAGE AND BULK FACTORS**

Soil Unit	Shrink/Bulk Factor
Surficial Soils	10-15% shrink
Otay Formation (To)	4-8% bulk
Metavolcanic Rock (Mzu) – rippable	10-15% bulk
Metavolcanic Rock (Mzu) – blasted	20-30% bulk

9.8 Subdrains

9.8.1 Conditions encountered prior to and during grading do not necessarily reveal the conditions that will be encountered once construction of the proposed homes is completed. Specifically, irrigation in both the subject lots and up gradient lots cannot be reasonably predicted. Therefore, the design and implementation of additional drainage mechanisms may be necessitated. The geologic units encountered on the site have permeability characteristics and/or fracture systems that could be susceptible under certain conditions to groundwater seepage. The use of canyon subdrains will be necessary to mitigate the potential for adverse impacts associated with seepage conditions. Figure 9 depicts a typical canyon subdrain detail. Drains within stability fill keyways should use 4-inch-diameter

pipes (see Figure 6). The locations of proposed canyon subdrains are presented on the Geologic Map, Figures 2 and 3, and should be shown on the final 40-scale grading plans. The actual subdrain locations will be determined in the field subsequent to the remedial grading. Appropriate subdrain outlets should be evaluated prior to finalizing 40-scale grading plans.

- 9.8.2 Rock fill areas should be provided with subdrains along their down-slope perimeters to mitigate the potential buildup of water derived from construction or landscape irrigation. Subdrains within and/or at the base of rock fill areas as determined by the engineering geologist should use 6-inch-diameter pipes. Rock fill drains should be constructed using the same requirements as canyon subdrains as shown on Figure 9.
- 9.8.3 Prior to outletting, the final 20-foot segment of a subdrain that will not be extended during future development should consist of non-perforated drainpipe. At the non-perforated/perforated interface, a seepage cutoff wall should be constructed on the downslope side of the junction in accordance with Figure 10. Subdrains that discharge into a natural drainage course or open space area should be provided with a permanent headwall structure in accordance with Figure 11.
- 9.8.4 Building pad areas adjacent to large ascending slopes may experience wet to saturated soil conditions due to irrigation practices or seepage. To reduce the potential for this to occur, consideration should be given to placing a subdrain along the base of the slopes to collect potential seepage and convey it to a suitable outlet. The drain should be sufficiently deep to intercept the seepage (on the order of 3 feet below finish grade) and constructed in accordance with the recommendations in the subdrain section of this report. The necessity for the drains should be discussed prior to grading on a slope specific basis. In addition, the project civil engineer should be consulted to evaluate the appropriate drain locations and necessary easements, building restriction zones or disclosure requirements that may be necessary. The drains should be surveyed for location and shown on the project as-built drawings.
- 9.8.5 The final grading plans should show the location of the proposed subdrains. Upon completion of remedial excavations and subdrain installation, the project civil engineer should survey the drain locations and prepare an “as-built” map depicting the existing conditions. The final outlet and connection locations should be determined during grading. Subdrains that will be extended on adjacent projects shortly after grading can be placed on formational material and a vertical riser should be placed at the end of the subdrain. The grading contractor should consider videoing the subdrains shortly after burial to check

proper installation and to check that the pipe has not been crushed. The contractor is responsible for the performance of the drains.

9.9 Soil Creep and Lateral Fill Extension

- 9.9.1 The planned compacted fill slopes possess a calculated factor of safety of at least 1.5 for surficial conditions as presented in Appendix D. The surficial condition assumes the soil would be saturated in the outer 3 feet of the slope face. To help reduce the effects of soil creep, landscaping with variable root depth should be planted soon after the construction of the slopes. In addition, rodent abatement is also important as part of the slope maintenance.
- 9.9.2 Buildings and structures should be setback from slopes in accordance with 2013 CBC Section 1808.7 and as recommended herein. Mitigation measures to reduce the effect of soil creep could include the use of pavers instead of relatively large concrete slabs-on-grade or smaller concrete slabs with expansion joints that would allow movement limiting unsightly distress. Also, pilasters for walls could be separated from other walls elements to allow lateral movement without causing distress.
- 9.9.3 The soil creep zone is usually isolated to the outer 3 to 5 feet of the slope face. The proposed residential structures and improvements are not planned within this zone.
- 9.9.4 Foundation recommendations for walls located adjacent to slopes are provided in the foundation section of this report. However, if planned retaining walls, screen walls, fencing, or similar improvements that are sensitive to movement are proposed at the top of slopes, we would recommend that the footings be deepened to reduce the effect of lateral fill extension.

9.10 Foundation and Concrete Slabs-On-Grade Recommendations

- 9.10.1 The foundation recommendations presented herein are for proposed one- to two-story residential structures. We separated the foundation recommendations into three categories based on either the maximum and differential fill thickness or Expansion Index. The foundation category criteria are presented in Table 9.10.1. Final foundation categories for each lot will be provided once site grading has been completed.

**TABLE 9.10.1
FOUNDATION CATEGORY CRITERIA**

Foundation Category	Maximum Fill Thickness, T (Feet)	Differential Fill Thickness, D (Feet)	Expansion Index (EI)
I	$T < 20$	--	$EI \leq 50$
II	$20 \leq T < 50$	$10 \leq D < 20$	$50 < EI \leq 90$
III	$T \geq 50$	$D \geq 20$	$90 < EI \leq 130$

9.10.2 Table 9.10.2 presents minimum foundation and interior concrete slab design criteria for conventional foundation systems.

**TABLE 9.10.2
CONVENTIONAL FOUNDATION RECOMMENDATIONS BY CATEGORY**

Foundation Category	Minimum Footing Embedment Depth (inches)	Continuous Footing Reinforcement	Interior Slab Reinforcement
I	12	Two No. 4 bars, one top and one bottom	6 x 6 - 10/10 welded wire mesh at slab mid-point
II	18	Four No. 4 bars, two top and two bottom	No. 3 bars at 24 inches on center, both directions at slab mid-point
III	24	Four No. 5 bars, two top and two bottom	No. 3 bars at 18 inches on center, both directions at slab mid-point

9.10.3 The embedment depths presented in Table 9.10.2 should be measured from the lowest adjacent pad grade for both interior and exterior footings. The conventional foundations should have a minimum width of 12 inches and 24 inches for continuous and isolated footings, respectively. Figure 12 presents a wall/column footing dimension detail depicting lowest adjacent pad grade.

9.10.4 Slabs that may receive moisture-sensitive floor coverings or may be used to store moisture-sensitive materials should be underlain by a vapor retarder. The vapor retarder design should be consistent with the guidelines presented in the American Concrete Institute's (ACI) *Guide for Concrete Slabs that Receive Moisture-Sensitive Flooring Materials* (ACI 302.2R-06). In addition, the membrane should be installed in accordance with manufacturer's recommendations and ASTM requirements and installed in a manner that prevents puncture. The vapor retarder used should be specified by the project architect or developer based on the

type of floor covering that will be installed and if the structure will possess a humidity-controlled environment.

9.10.5 Placement of 3 inches and 4 inches of sand is common practice in Southern California for 5-inch and 4-inch thick slabs, respectively. The foundation engineer should provide appropriate concrete mix design criteria and curing measures that may be utilized to assure proper curing of the slab to reduce the potential for rapid moisture loss and subsequent cracking and/or slab curl. We suggest that the foundation engineer present concrete mix design and proper curing methods on the foundation plans. It is critical that the foundation contractor understands and follows the recommendations presented on the foundation plans.

9.10.6 As an alternative to the conventional foundation recommendations, consideration should be given to the use of post-tensioned concrete slab and foundation systems for the support of the proposed structures. The post-tensioned systems should be designed by a structural engineer experienced in post-tensioned slab design and design criteria of the Post-Tensioning Institute (PTI), Third Edition, as required by the 2013 California Building Code (CBC Section 1808.6). Although this procedure was developed for expansive soil conditions, we understand it can also be used to reduce the potential for foundation distress due to differential fill settlement. The post-tensioned design should incorporate the geotechnical parameters presented on Table 9.10.3 for the particular Foundation Category designated. The parameters presented in Table 9.10.3 are based on the guidelines presented in the PTI, Third Edition design manual. The foundations for the post-tensioned slabs should be embedded in accordance with the recommendations of the structural engineer.

**TABLE 9.10.3
POST-TENSIONED FOUNDATION SYSTEM DESIGN PARAMETERS**

Post-Tensioning Institute (PTI) Third Edition Design Parameters	Foundation Category		
	I	II	III
Thornthwaite Index	-20	-20	-20
Equilibrium Suction	3.9	3.9	3.9
Edge Lift Moisture Variation Distance, e_M (feet)	5.3	5.1	4.9
Edge Lift, y_M (inches)	0.61	1.10	1.58
Center Lift Moisture Variation Distance, e_M (feet)	9.0	9.0	9.0
Center Lift, y_M (inches)	0.30	0.47	0.66

- 9.10.7 If the structural engineer proposes a post-tensioned foundation design method other than the 2013 CBC:
- The criteria presented in Table 9.10.3 are still applicable.
 - Interior stiffener beams should be used for Foundation Categories II and III.
 - The width of the perimeter foundations should be at least 12 inches.
 - The perimeter footing embedment depths should be at least 12 inches, 18 inches and 24 inches for foundation categories I, II, and III, respectively. The embedment depths should be measured from the lowest adjacent pad grade.
- 9.10.8 Foundation systems for the buildings that possess a foundation Category I and a “very low” expansion potential (Expansion Index of 20 or less) can be designed using the method described in in Section 1808 of the 2013 CBC. If post-tensioned foundations are planned, an alternative, commonly accepted design method (other than PTI Third Edition) can be used. However, the post-tensioned foundation system should be designed with a total and differential deflection of 1 inch. Geocon Incorporated should be contacted to review the plans and provide additional information, including additional laboratory testing, if necessary.
- 9.10.9 Our experience indicates post-tensioned slabs are susceptible to excessive edge lift, regardless of the underlying soil conditions. Placing reinforcing steel at the bottom of the perimeter footings and the interior stiffener beams may mitigate this potential. Because of the placement of the reinforcing tendons in the top of the slab, the resulting eccentricity after tensioning reduces the ability of the system to mitigate edge lift. The structural engineer should design the foundation system to reduce the potential of edge lift occurring for the proposed structures.
- 9.10.10 During the construction of the post-tension foundation system, the concrete should be placed monolithically. Under no circumstances should cold joints form between the footings/grade beams and the slab during the construction of the post-tension foundation system.
- 9.10.11 Category I, II, or III foundations may be designed for an allowable soil bearing pressure of 2,000 pounds per square foot (psf) (dead plus live load). This bearing pressure may be increased by one-third for transient loads due to wind or seismic forces.
- 9.10.12 Isolated footings, if present, should have the minimum embedment depth and width recommended for conventional foundations for a particular foundation category. The use of isolated footings, which are located beyond the perimeter of the building and support structural elements connected to the building, are not recommended for Category III.

Where this condition cannot be avoided, the isolated footings should be connected to the building foundation system with grade beams.

- 9.10.13 For Foundation Category III, consideration should be given to using interior stiffening beams and connecting isolated footings and/or increasing the slab thickness. In addition, consideration should be given to connecting patio slabs, which exceed 5 feet in width, to the building foundation to reduce the potential for future separation to occur.
- 9.10.14 Special subgrade presaturation is not deemed necessary prior to placing concrete; however, the exposed foundation and slab subgrade soil should be moisture conditioned, as necessary, to maintain a moist condition as would be expected in such concrete placement.
- 9.10.15 Where buildings or other improvements are planned near the top of a slope steeper than 3:1 (horizontal to vertical), special foundations and/or design considerations are recommended due to the tendency for lateral soil movement to occur.
- For fill slopes less than 20 feet high, building footings should be deepened such that the bottom outside edge of the footing is at least 7 feet horizontally from the face of the slope.
 - When located next to a descending 3:1 (horizontal to vertical) fill slope or steeper, conventional foundations should be extended to a depth where the minimum horizontal distance is equal to $H/3$ (where H equals the vertical distance from the top of the fill slope to the base of the fill soil) with a minimum of 7 feet but need not exceed 40 feet. The horizontal distance is measured from the outer, deepest edge of the footing to the face of the slope. A post-tensioned slab and foundation system or mat foundation system can be used to reduce the minimum setback to 7 feet and will help prevent distress in the structures associated with slope creep and lateral fill extension. Specific design parameters or recommendations for either of these alternatives can be provided once the building location and fill slope geometry have been determined.
 - Geocon Incorporated should be contacted to review the pool plans and the specific site conditions to provide additional recommendations, if necessary.
 - Swimming pools located within 7 feet of the top of cut or fill slopes are not recommended. Where such a condition cannot be avoided, the portion of the swimming pool wall within 7 feet of the slope face be designed assuming that the adjacent soil provides no lateral support.
 - Although other improvements, which are relatively rigid or brittle, such as concrete flatwork or masonry walls, may experience some distress if located near the top of a slope, it is generally not economical to mitigate this potential. It may be possible, however, to incorporate design measures that would permit some lateral soil movement without causing extensive distress. Geocon Incorporated should be consulted for specific recommendations.

- 9.10.16 The recommendations of this report are intended to reduce the potential for cracking of slabs due to expansive soil (if present), differential settlement of existing soil or soil with varying thicknesses. However, even with the incorporation of the recommendations presented herein, foundations, stucco walls, and slabs-on-grade placed on such conditions may still exhibit some cracking due to soil movement and/or shrinkage. The occurrence of concrete shrinkage cracks is independent of the supporting soil characteristics. Their occurrence may be reduced and/or controlled by limiting the slump of the concrete, proper concrete placement and curing, and by the placement of crack control joints at periodic intervals, in particular, where re-entrant slab corners occur.
- 9.10.17 Geocon Incorporated should be consulted to provide additional design parameters as required by the structural engineer.

9.11 Exterior Concrete Flatwork

- 9.11.1 Exterior concrete flatwork not subject to vehicular traffic should be constructed in accordance with the recommendations herein assuming the subgrade materials possess an Expansion Index of 90 or less. Slab panels should be a minimum of 4 inches thick and when in excess of 8 feet square should be reinforced with 6x6-W2.9/W2.9 (6x6-6/6) welded wire mesh or No. 3 reinforcing bars spaced 18 inches center-to-center in both directions to reduce the potential for cracking. In addition, concrete flatwork should be provided with crack control joints to reduce and/or control shrinkage cracking. Crack control spacing should be determined by the project structural engineer based upon the slab thickness and intended usage. Criteria of the American Concrete Institute (ACI) should be taken into consideration when establishing crack control spacing. Subgrade soil for exterior slabs not subjected to vehicle loads should be compacted in accordance with criteria presented in the grading section prior to concrete placement. Subgrade soil should be properly compacted and the moisture content of subgrade soil should be verified prior to placing concrete. Base materials will not be required below concrete improvements.
- 9.11.2 Even with the incorporation of the recommendations of this report, the exterior concrete flatwork has a potential to experience some uplift due to expansive soil beneath grade. The steel reinforcement should overlap continuously in flatwork to reduce the potential for vertical offsets within flatwork. Additionally, flatwork should be structurally connected to the curbs, where possible, to reduce the potential for offsets between the curbs and the flatwork.
- 9.11.3 Where exterior flatwork abuts the structure at entrant or exit points, the exterior slab should be dowelled into the structure's foundation stemwall. This recommendation is intended to reduce the potential for differential elevations that could result from differential settlement

or minor heave of the flatwork. Dowelling details should be designed by the project structural engineer.

- 9.11.4 The recommendations presented herein are intended to reduce the potential for cracking of exterior slabs as a result of differential movement. However, even with the incorporation of the recommendations presented herein, slabs-on-grade will still crack. The occurrence of concrete shrinkage cracks is independent of the soil supporting characteristics. Their occurrence may be reduced and/or controlled by limiting the slump of the concrete, the use of crack control joints and proper concrete placement and curing. Crack control joints should be spaced at intervals no greater than 12 feet. Literature provided by the Portland Concrete Association (PCA) and American Concrete Institute (ACI) present recommendations for proper concrete mix, construction, and curing practices, and should be incorporated into project construction.

9.12 Conventional Retaining Wall Recommendations

- 9.12.1 Retaining walls not restrained at the top and having a level backfill surface should be designed for an active soil pressure equivalent to the pressure exerted by a fluid density of 40 pounds per cubic foot (pcf). Where the backfill will be inclined at no steeper than 2:1 (horizontal to vertical), an active soil pressure of 55 pcf is recommended. These soil pressures assume that the backfill materials within an area bounded by the wall and a 1:1 plane extending upward from the base of the wall possess an EI of 90 or less. For those lots where backfill materials do not conform to the criteria herein, Geocon Incorporated should be consulted for additional recommendations.
- 9.12.2 Unrestrained walls are those that are allowed to rotate more than $0.001H$ (where H equals the height of the retaining portion of the wall in feet) at the top of the wall. Where walls are restrained from movement at the top, an additional uniform pressure of $7H$ psf should be added to the active soil pressure.
- 9.12.3 The structural engineer should determine the seismic design category for the project in accordance with Section 1613 of the CBC. If the project possesses a seismic design category of D, E, or F, retaining walls that support more than 6 feet of backfill should be designed with seismic lateral pressure in accordance with Section 18.3.5.12 of the 2013 CBC. The seismic load is dependent on the retained height where H is the height of the wall, in feet, and the calculated loads result in pounds per square foot (psf) exerted at the base of the wall and zero at the top of the wall. A seismic load of $12H$ should be used for design. We used the peak ground acceleration adjusted for Site Class effects, PGA_M , of $0.384g$ calculated from ASCE 7-10 Section 11.8.3 and applied a pseudo-static coefficient of 0.33.

- 9.12.4 Unrestrained walls will move laterally when backfilled and loading is applied. The amount of lateral deflection is dependent on the wall height, the type of soil used for backfill, and loads acting on the wall. The retaining walls and improvements above the retaining walls should be designed to incorporate an appropriate amount of lateral deflection as determined by the structural engineer.
- 9.12.5 Retaining walls should be provided with a drainage system adequate to prevent the buildup of hydrostatic forces and waterproofed as required by the project architect. The soil immediately adjacent to the backfilled retaining wall should be composed of free draining material completely wrapped in Mirafi 140 (or equivalent) filter fabric for a lateral distance of 1 foot for the bottom two-thirds of the height of the retaining wall. The upper one-third should be backfilled with less permeable compacted fill to reduce water infiltration. The use of drainage openings through the base of the wall (weep holes) is not recommended where the seepage could be a nuisance or otherwise adversely affect the property adjacent to the base of the wall. The recommendations herein assume a properly compacted granular (EI of 50 or less) free-draining backfill material with no hydrostatic forces or imposed surcharge load. Figure 13 presents a typical retaining wall drain detail. If conditions different than those described are expected or if specific drainage details are desired, Geocon Incorporated should be contacted for additional recommendations.
- 9.12.6 In general, wall foundations having a minimum depth and width of 1 foot may be designed for an allowable soil bearing pressure of 2,000 psf. The proximity of the foundation to the top of a slope steeper than 3:1 could impact the allowable soil bearing pressure. Therefore, Geocon Incorporated should be consulted where such a condition is expected.
- 9.12.7 The recommendations presented herein are generally applicable to the design of rigid concrete or masonry retaining walls having a maximum height of 8 feet. In the event that walls higher than 8 feet or other types of walls are planned, Geocon Incorporated should be consulted for additional recommendations.

9.13 Mechanically Stabilized Earth (MSE) Retaining Walls

- 9.13.1 MSE retaining walls are alternative walls that consist of modular block facing units with geogrid reinforced earth behind the block. The reinforcement grid attaches to the block units and is typically placed at specified vertical intervals and embedment lengths. The grid length and spacing will be determined by the wall designer.
- 9.13.2 The geotechnical parameters listed in Table 9.13 can be used for preliminary design of the MSE walls (including proposed plantable MSE walls). Once the location of the backfill soil

has been determined, laboratory testing should be performed to check that the shear strength parameters used in the design of the MSE walls meet the required strength within the reinforced zone.

**TABLE 9.13
GEOTECHNICAL PARAMETERS FOR MSE WALLS**

Parameter	Reinforced Zone	Retained Zone	Foundation Zone
Angle of Internal Friction	28 degrees	28 degrees	28 degrees
Cohesion	200 psf	200 psf	200 psf
Wet Unit Density	130 pcf	130 pcf	130 pcf

- 9.13.3 The soil parameters presented in Table 9.13 are based on our experience, direct shear-strength tests performed during the geotechnical investigation and represent some of the onsite materials. The wet unit density values presented in Table 9.13 can be used for design but actual in-place densities may range from approximately 90 to 135 pounds per cubic foot. Geocon has no way of knowing which materials will actually be used as backfill behind the wall during construction. It is up to the wall designers to use their judgment in selection of the design parameters. As such, once backfill materials have been selected and/or stockpiled, sufficient shear tests should be conducted on samples of the proposed backfill materials to check that they conform to actual design values. Results should be provided to the designer to re-evaluate stability of the walls. Dependent upon test results, the designer may require modifications to the original wall design (e.g., longer reinforcement embedment lengths and/or steel reinforcement).
- 9.13.4 The foundation zone is the area where the footing is embedded, the reinforced zone is the area of the backfill that possesses the reinforcing fabric, and the retained zone is the area behind the reinforced zone.
- 9.13.5 Wall foundations having a minimum depth and width of one foot may be designed for an allowable soil bearing pressure of 2,000 psf. This soil pressure may be increased by 300 psf and 500 psf for each additional foot of foundation width and depth, respectively, up to a maximum allowable soil bearing pressure of 3,500 psf.
- 9.13.6 Backfill materials within the reinforced zone should be compacted to a dry density of at least 90 percent of the laboratory maximum dry density near to slightly above optimum moisture content in accordance with ASTM D 1557. This is applicable to the entire embedment width of the reinforcement. Typically, wall designers specify no heavy compaction equipment within 3 feet of the face of the wall. However, smaller equipment

(e.g., walk-behind, self-driven compactors or hand whackers) can be used to compact the materials without causing deformation of the wall. If the designer specifies no compactive effort for this zone, the materials are essentially not properly compacted and the reinforcement grid within the uncompacted zone should not be relied upon for reinforcement, and overall embedment lengths will have to be increased to account for the difference.

- 9.13.7 Select backfill materials may be required to be in accordance with the MSE retaining wall system. Materials as outlined in the specifications of the retaining wall plans may be generated and stockpiled during grading, if encountered, or may require import. Geocon should perform laboratory tests during the backfill materials to check that soil properties are in accordance with the retaining wall plans and specifications.
- 9.13.8 The wall should be provided with a drainage system sufficient to prevent excessive seepage through the wall and the base of the wall, thus preventing hydrostatic pressures behind the wall.
- 9.13.9 Geosynthetic reinforcement must elongate to develop full tensile resistance. This elongation generally results in movement at the top of the wall. The amount of movement is dependent upon the height of the wall (e.g., higher walls rotate more) and the type of reinforcing grid used. In addition, over time the reinforcement grid has been known to exhibit creep (sometimes as much as 5 percent) and can undergo additional movement. Given this condition, the owner should be aware that structures and pavement placed within the reinforced and retained zones of the wall may undergo movement.
- 9.13.10 The MSE wall contractor should provide the estimated deformation of wall and adjacent ground in associated with wall construction. The calculated horizontal and vertical deformations should be determined by the wall designer. The estimated movements should be provided to the project structural engineer to determine if the planned improvements can tolerate the expected movements.
- 9.13.11 The MSE wall designer/contractor should review this report, including the slope stability requirements, and incorporate our recommendations as presented herein. We should be provided the plans for the MSE walls to check if they are in conformance with our recommendations prior to issuance of a permit and construction.

9.14 Lateral Loads

9.14.1 For resistance to lateral loads, an allowable passive earth pressure equivalent to a fluid density of 350 pcf is recommended for footings or shear keys poured neat against properly compacted granular fill or formational materials. The allowable passive pressure assumes a horizontal surface extending away from the base of the wall at least 5 feet or three times the height of the surface generating the passive pressure, whichever is greater.

9.14.2 The upper 12 inches of material not protected by floor slabs or pavement should not be included in the design for lateral resistance. An allowable friction coefficient of 0.35 may be used for resistance to sliding between soil and concrete. This friction coefficient may be combined with the allowable passive earth pressure when determining resistance to lateral loads.

9.15 Preliminary Pavement Recommendations

9.15.1 The final pavement sections for roadways should be based on the R-Value of the subgrade soils encountered at final subgrade elevation. Streets should be designed in accordance with the City of Chula specifications when final Traffic Indices and R-Value test results of subgrade soil are completed. Based on the results of our laboratory R-Value testing, we have assumed R-Values of 10 and 26 for the subgrade soil for the purposes of this preliminary analysis. Preliminary flexible pavement sections are presented in Table 9.15.1.

**TABLE 9.15.1
PRELIMINARY FLEXIBLE PAVEMENT SECTIONS**

Location	Assumed Traffic Index	Assumed Subgrade R-Value	Asphalt Concrete (inches)	Crushed Aggregate Base (inches)
Roadways servicing light-duty vehicles	5.5	10	3.0	11
		26	3.0	8
Roadways servicing heavy truck vehicles	7.0	10	4.0	15
		26	4.0	11
Class II Collector	7.5	10	4.5	15
		26	4.5	11
Class II Collector	8.0	10	5.0	16
		26	5.0	12
Class I Collector	8.5	10	5.0	18
		26	5.0	14
Industrial/4 Lane Major	9.0	10	5.5	19
		26	5.5	14
Main Street (6 Lane Major/Prime Arterial)	9.5	10	6.0	20
		26	6.0	15

- 9.15.2 The upper 12 inches of the subgrade soil should be compacted to a dry density of at least 95 percent of the laboratory maximum dry density near to slightly above optimum moisture content beneath pavement sections.
- 9.15.3 The base thickness can be reduced if a reinforcement geogrid is used during the installation of the pavement and approved by the City of Chula Vista. Geocon should be contact for additional recommendations, if required.
- 9.15.4 Prior to installation of base paving and placement of curb/gutter form work related to approved construction plans, the applicant should demonstrate to the City Engineer's satisfaction that highly expansive soil (with an expansion index greater than 90) are not within the upper five feet of any public right of way or public easement. Applicant should selectively grade fill soil with an expansion index of 90 or less within the upper five feet of public right of way or propose an alternate method to mitigate expansive soil. Said alternative method should be subject to the approval of the City Engineer prior to placement of curb and gutter, sidewalk or aggregate base. Additionally, formational materials within three feet of subgrade should be tested for expansion, and if determined to be highly expansive, should be replaced with a soil satisfactory to the City Engineer.
- 9.15.5 The crushed aggregated base and asphalt concrete materials should conform to Section 26-1.028 of the *Standard Specifications for Public Works Construction* (Greenbook) and the *City of Chula Vista Standard Special Provisions – October 2008*. Base materials should be compacted to a dry density of at least 95 percent of the laboratory maximum dry density near to slightly above optimum moisture content. Asphalt concrete should be compacted to a density of 92 to 96 percent of the laboratory Theoretical Maximum (Rice) density in accordance with ASTM D 2726.
- 9.15.6 A rigid Portland cement concrete (PCC) pavement section should be placed in driveway aprons and cross gutters. We calculated the rigid pavement section in general conformance with the procedure recommended by the American Concrete Institute report ACI 330R-08 Guide for Design and Construction of Concrete Parking Lots using the parameters presented in Table 9.15.2.

**TABLE 9.15.2
RIGID PAVEMENT DESIGN PARAMETERS**

Design Parameter	Design Value
Modulus of subgrade reaction, k	100 pci
Modulus of rupture for concrete, M_R	500 psi
Traffic Category, TC	C and D
Average daily truck traffic, ADTT	700

9.15.7 Based on the criteria presented herein, the PCC pavement sections should have a minimum thickness as presented in Table 9.15.3.

**TABLE 9.15.3
RIGID PAVEMENT RECOMMENDATIONS**

Location	Portland Cement Concrete (inches)
Roadways (TC=C)	7
Main Street (TC=D)	8

9.15.8 The PCC pavement should be placed over subgrade soil that is compacted to a dry density of at least 95 percent of the laboratory maximum dry density near to slightly above optimum moisture content. This pavement section is based on a minimum concrete compressive strength of approximately 3,000 psi (pounds per square inch). Base material will not be required beneath concrete improvements.

9.15.9 A thickened edge or integral curb should be constructed on the outside of concrete slabs subjected to wheel loads. The thickened edge should be 1.2 times the slab thickness or a minimum thickness of 2 inches, whichever results in a thicker edge, and taper back to the recommended slab thickness 4 feet behind the face of the slab (e.g., an 8-inch-thick slab would have a 10-inch-thick edge). Reinforcing steel will not be necessary within the concrete for geotechnical purposes with the possible exception of dowels at construction joints as discussed herein.

9.15.10 To control the location and spread of concrete shrinkage cracks, crack-control joints (weakened plane joints) should be included in the design of the concrete pavement slab. Crack-control joints should not exceed 30 times the slab thickness with a maximum spacing of 15 feet for the 8-inch-thick slabs (e.g., an 8-inch-thick slab would have a 15-foot spacing pattern), and should be sealed with an appropriate sealant to prevent the migration

of water through the control joint to the subgrade materials. The depth of the crack-control joints should be determined by the referenced ACI report.

9.15.11 To provide load transfer between adjacent pavement slab sections, a butt-type construction joint should be constructed. The butt-type joint should be thickened by at least 20 percent at the edge and taper back at least 4 feet from the face of the slab. As an alternative to the butt-type construction joint, dowelling can be used between construction joints for pavements of 7 inches or thicker. As discussed in the referenced ACI guide, dowels should consist of smooth, 1-inch-diameter reinforcing steel 14 inches long embedded a minimum of 6 inches into the slab on either side of the construction joint. Dowels should be located at the midpoint of the slab, spaced at 12 inches on center and lubricated to allow joint movement while still transferring loads. In addition, tie bars should be installed as recommended in Section 3.8.3 of the referenced ACI guide. The structural engineer should provide other alternative recommendations for load transfer.

9.15.12 The performance of pavement is highly dependent on providing positive surface drainage away from the edge of the pavement. Ponding of water on or adjacent to the pavement will likely result in pavement distress and subgrade failure if not mitigated. Drainage from landscaped areas should be directed to controlled drainage structures. Landscape areas adjacent to the edge of asphalt pavements are not recommended due to the potential for surface or irrigation water to infiltrate the underlying permeable aggregate base and cause distress. Where such a condition cannot be avoided, consideration should be given to incorporating measures that will significantly reduce the potential for subsurface water migration into the aggregate base. If planter islands are planned, the perimeter curb should extend at least 6 inches

9.16 Site Drainage and Moisture Protection

9.16.1 Adequate site drainage is critical to reduce the potential for differential soil movement, erosion and subsurface seepage. Under no circumstances should water be allowed to pond adjacent to footings. The site should be graded and maintained such that surface drainage is directed away from structures in accordance with 2013 CBC 1804.3 or other applicable standards. In addition, surface drainage should be directed away from the top of slopes into swales or other controlled drainage devices. Roof and pavement drainage should be directed into conduits that carry runoff away from the proposed structure.

9.16.2 In the case of basement walls or building walls retaining landscaping areas, a waterproofing system should be used on the wall and joints, and a Miradrain drainage panel (or similar) should be placed over the waterproofing. The project architect or civil engineer should provide detailed specifications on the plans for all waterproofing and drainage.

- 9.16.3 Underground utilities should be leak free. Utility and irrigation lines should be checked periodically for leaks, and detected leaks should be repaired promptly. Detrimental soil movement could occur if water is allowed to infiltrate the soil for prolonged periods of time.
- 9.16.4 If detention basins, bioswales, retention basins, water infiltration, low impact development (LID), or storm water management devices are being considered, Geocon Incorporated should be retained to provide recommendations pertaining to the geotechnical aspects of possible impacts and design.
- 9.16.5 If not properly constructed, there is a potential for distress to improvements and properties located hydrologically down gradient or adjacent to these devices. Factors such as the amount of water to be detained, its residence time, and soil permeability have an important effect on seepage transmission and the potential adverse impacts that may occur if the storm water management features are not properly designed and constructed. Based on our experience with similar soil conditions, infiltration areas are considered infeasible due to the poor percolation and lateral migration characteristics. We have not performed a hydrogeology study at the site. Down-gradient and adjacent structures may be subjected to seeps, movement of foundations and slabs, or other impacts as a result of water infiltration.
- 9.16.6 We performed slope stability analyses incorporating a water surface within the underlying soil. Based on our calculations, the existing slope adjacent to the southwestern basin would possess a factor of safety of at least 1.5. However, storm water management devices should be properly constructed to prevent water infiltration and lined with an impermeable liner (e.g. High-density polyethylene, HDPE, with a thickness of about 30 mil or equivalent Polyvinyl Chloride, PVC, liner) due to the presence of the adjacent slope. The devices should also be installed in accordance with the manufacturer's recommendations.
- 9.16.7 The United States Department of Agriculture (USDA), Natural Resources Conservation Services possesses general information regarding the existing soil conditions for areas within the United States. Table 9.16.1 presents the soil name based on the USDA website.

**TABLE 9.16.1
EXISTING SOIL CONDITIONS BASED ON USDA WEBSITE**

Map Unit Name	Map Unit Symbol	Approximate Percentage of Property	Hydrologic Soil Group
Diablo clay, 2 to 9 percent slopes	DaC	22.4	D
Diablo clay, 9 to 15 percent slopes	DaD	24.9	D
Diablo clay, 15 to 30 percent slopes	DaE	0.9	D
Las Posas stony fine sandy loam, 30 to 65 percent slope	LrG	11.2	C
Linne clay loam, 9 to 30 percent slopes	LsE	12.2	C

9.16.8 The USDA website also provides the Hydrologic Soil Group. Based on the USDA website, the soil is classified as a Soil Group C and D. Table 9.16.2 presents the description of Hydrologic Soil Group. If the soil is assigned to a dual hydrologic group (A/D, B/D, or C/D), the first letter is for drained areas and the second is for undrained areas. Only the soils that in the natural condition are in group D are assigned to dual classes.

**TABLE 9.16.2
SATURATED PERMEABILITY TEST RESULTS**

Soil Group	Soil Group Definition
A	Soils having a high infiltration rate (low runoff potential) when thoroughly wet. These consist mainly of deep, well drained to excessively drained sands or gravelly sands. These soils have a high rate of water transmission.
B	Soils having a moderate infiltration rate when thoroughly wet. These consist chiefly of moderately deep or deep, moderately well drained or well drained soils that have moderately fine texture to moderately coarse texture. These soils have a moderate rate of water transmission.
C	Soils having a slow infiltration rate when thoroughly wet. These consist chiefly of soils having a layer that impedes the downward movement of water or soils of moderately fine texture or fine texture. These soils have a slow rate of water transmission.
D	Soils having a very slow infiltration rate (high runoff potential) when thoroughly wet. These consist chiefly of clays that have a high shrink-swell potential, soils that have a high water table, soils that have a claypan or clay layer at or near the surface, and soils that are shallow over nearly impervious material. These soils have a very slow rate of water transmission.

9.17 Grading and Foundation Plan Review

9.17.1 Geocon Incorporated should review the 40-scale grading plans and building foundation plans for the project prior to final design submittal to evaluate whether additional analysis and/or recommendations are required.

LIMITATIONS AND UNIFORMITY OF CONDITIONS

1. The recommendations of this report pertain only to the site investigated and are based upon the assumption that the soil conditions do not deviate from those disclosed in the investigation. If any variations or undesirable conditions are encountered during construction, or if the proposed construction will differ from that anticipated herein, Geocon Incorporated should be notified so that supplemental recommendations can be given. The evaluation or identification of the potential presence of hazardous materials was not part of the scope of services provided by Geocon Incorporated.
2. This report is issued with the understanding that it is the responsibility of the owner, or of his representative, to ensure that the information and recommendations contained herein are brought to the attention of the architect and engineer for the project and incorporated into the plans, and the necessary steps are taken to see that the contractor and subcontractors carry out such recommendations in the field.
3. The findings of this report are valid as of the present date. However, changes in the conditions of a property can occur with the passage of time, whether they are due to natural processes or the works of man on this or adjacent properties. In addition, changes in applicable or appropriate standards may occur, whether they result from legislation or the broadening of knowledge. Accordingly, the findings of this report may be invalidated wholly or partially by changes outside our control. Therefore, this report is subject to review and should not be relied upon after a period of three years.
4. The firm that performed the geotechnical investigation for the project should be retained to provide testing and observation services during construction to provide continuity of geotechnical interpretation and to check that the recommendations presented for geotechnical aspects of site development are incorporated during site grading, construction of improvements, and excavation of foundations. If another geotechnical firm is selected to perform the testing and observation services during construction operations, that firm should prepare a letter indicating their intent to assume the responsibilities of project geotechnical engineer of record. A copy of the letter should be provided to the regulatory agency for their records. In addition, that firm should provide revised recommendations concerning the geotechnical aspects of the proposed development, or a written acknowledgement of their concurrence with the recommendations presented in our report. They should also perform additional analyses deemed necessary to assume the role of Geotechnical Engineer of Record.

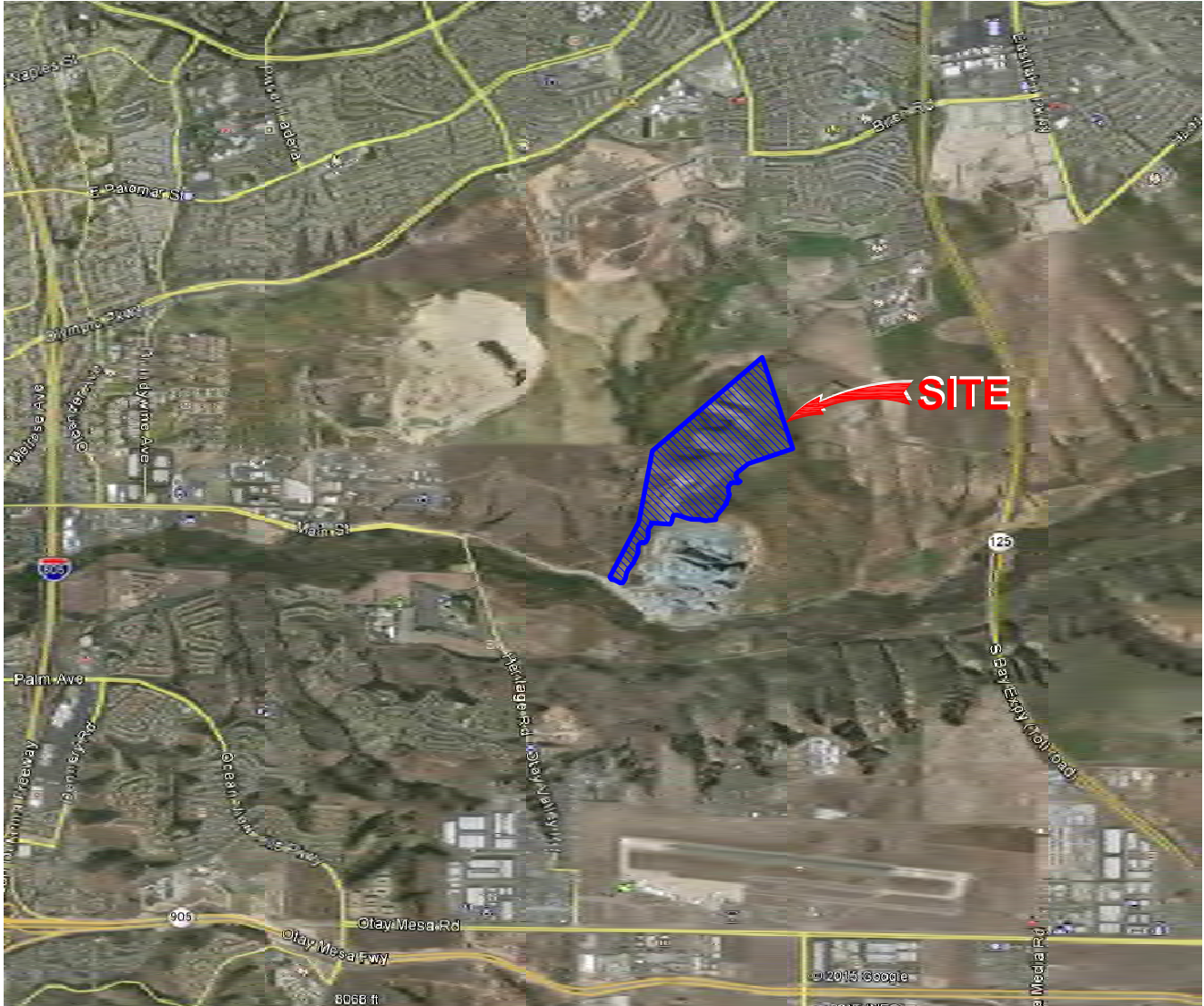

THE GEOGRAPHICAL INFORMATION MADE AVAILABLE FOR DISPLAY WAS PROVIDED BY GOOGLE EARTH, SUBJECT TO A LICENSING AGREEMENT. THE INFORMATION IS FOR ILLUSTRATIVE PURPOSES ONLY; IT IS NOT INTENDED FOR CLIENT'S USE OR RELIANCE AND SHALL NOT BE REPRODUCED BY CLIENT. CLIENT SHALL INDEMNIFY, DEFEND AND HOLD HARMLESS GEOCON FROM ANY LIABILITY INCURRED AS A RESULT OF SUCH USE OR RELIANCE BY CLIENT.



NO SCALE

VICINITY MAP

GEOCON
INCORPORATED



GEOTECHNICAL ■ ENVIRONMENTAL ■ MATERIALS
6960 FLANDERS DRIVE - SAN DIEGO, CALIFORNIA 92121 - 2974
PHONE 858 558-6900 - FAX 858 558-6159

OTAY RANCH VILLAGE 4 CHULA VISTA, CALIFORNIA

RM / AML

DSK/GTYPD

DATE

PROJECT NO. G1806 - 11 - 01

FIG. 1

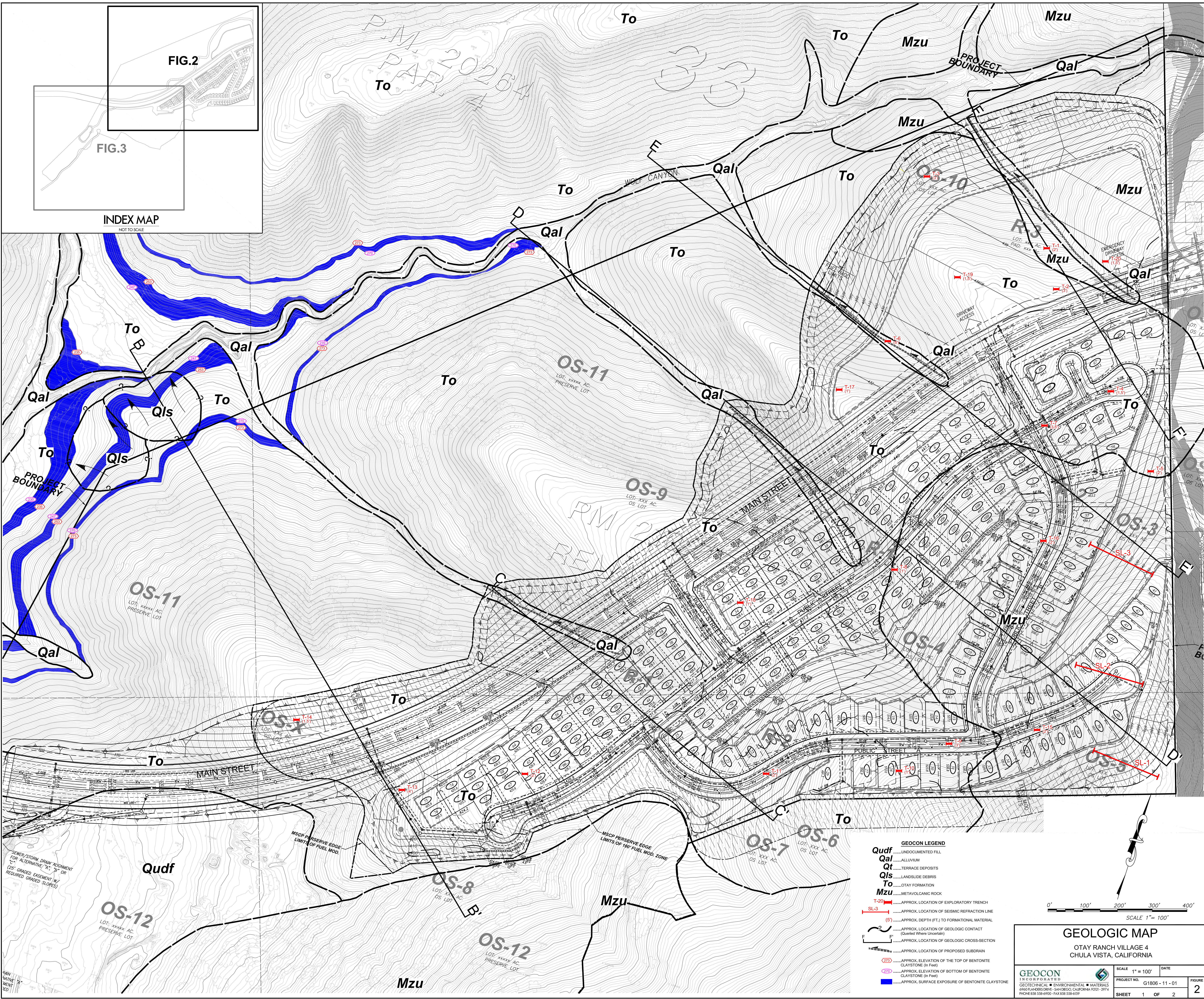

FIG.2

FIG.3

INDEX MAP
NOT TO SCALE

SEWER/STORM DRAIN ALIGNMENT FOR ALTERNATIVE "A", 7" OR 12" GRADED EASEMENT (W/ REQUIRED GRADED SLOPES)

RAIN WATER MANAGEMENT

- GEOCON LEGEND**
- Qudf** UNDOCUMENTED FILL
 - Qal** ALLUVIUM
 - Qt** TERRACE DEPOSITS
 - Qls** LANDSLIDE DEBRIS
 - To** OTAY FORMATION
 - Mzu** METAVOLCANIC ROCK
 - T-20** APPROX. LOCATION OF EXPLORATORY TRENCH
 - SL-3** APPROX. LOCATION OF SEISMIC REFRACTION LINE
 - (5)** APPROX. DEPTH (FT.) TO FORMATIONAL MATERIAL
 - F** APPROX. LOCATION OF GEOLOGIC CONTACT (Quarries Where Shown)
 - F** APPROX. LOCATION OF GEOLOGIC CROSS-SECTION
 - APPROX. LOCATION OF PROPOSED SUBDRAIN
 - APPROX. ELEVATION OF THE TOP OF BENTONITE CLAYSTONE (In Feet)
 - APPROX. ELEVATION OF BOTTOM OF BENTONITE CLAYSTONE (In Feet)
 - █** APPROX. SURFACE EXPOSURE OF BENTONITE CLAYSTONE

0' 100' 200' 300' 400'
SCALE 1" = 100'

GEOLOGIC MAP
OTAY RANCH VILLAGE 4
CHULA VISTA, CALIFORNIA

GEOCON INCORPORATED GEOTECHNICAL & ENVIRONMENTAL MATERIALS 6900 RANDERS DRIVE - SAN DIEGO, CALIFORNIA 92121-2974 PHONE 619-558-6900 - FAX 619-558-6159	SCALE 1" = 100'	DATE
PROJECT NO. G1806-11-01	FIGURE 2	
SHEET 1 OF 2		

SEE FIGURE 3

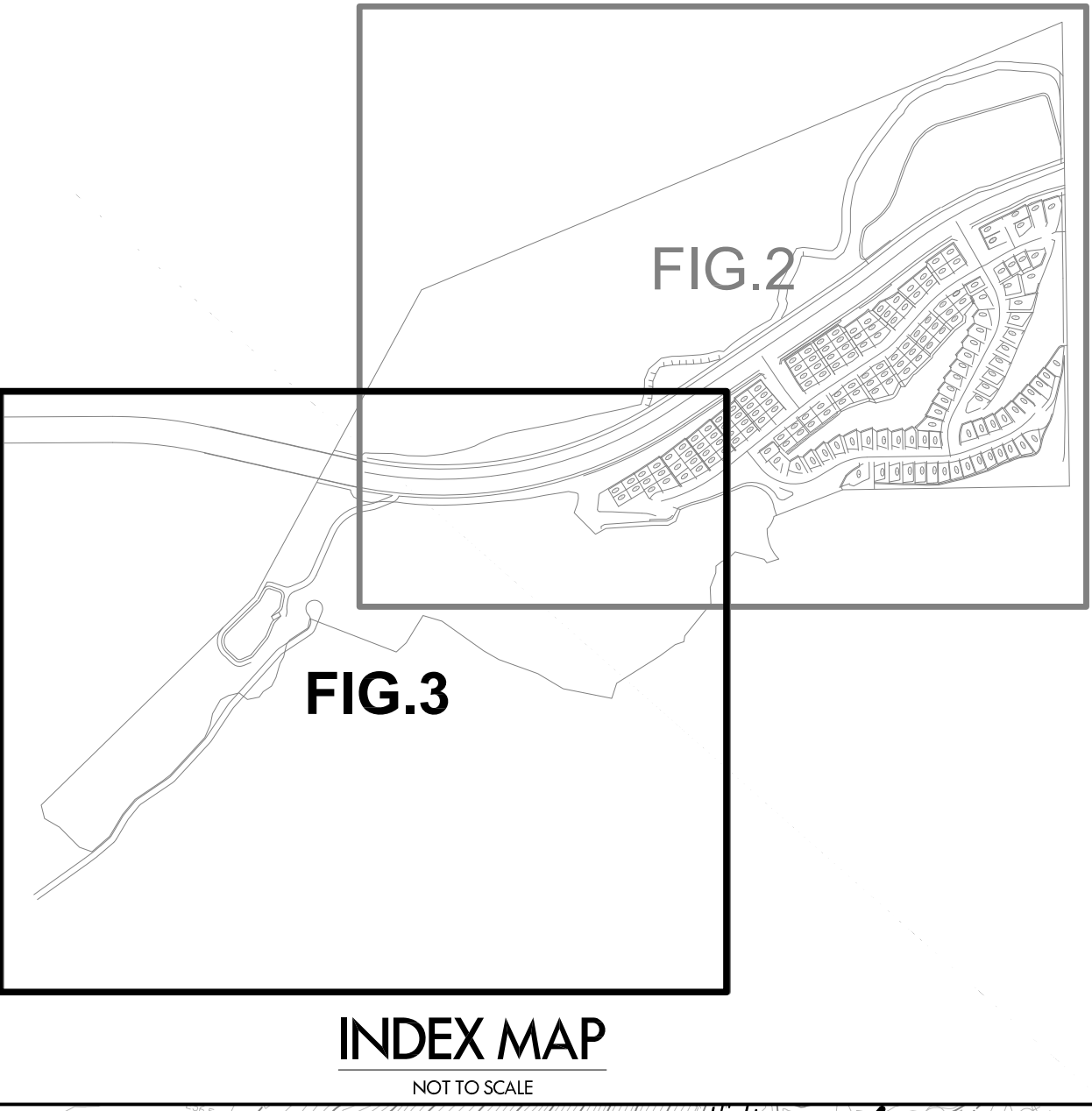
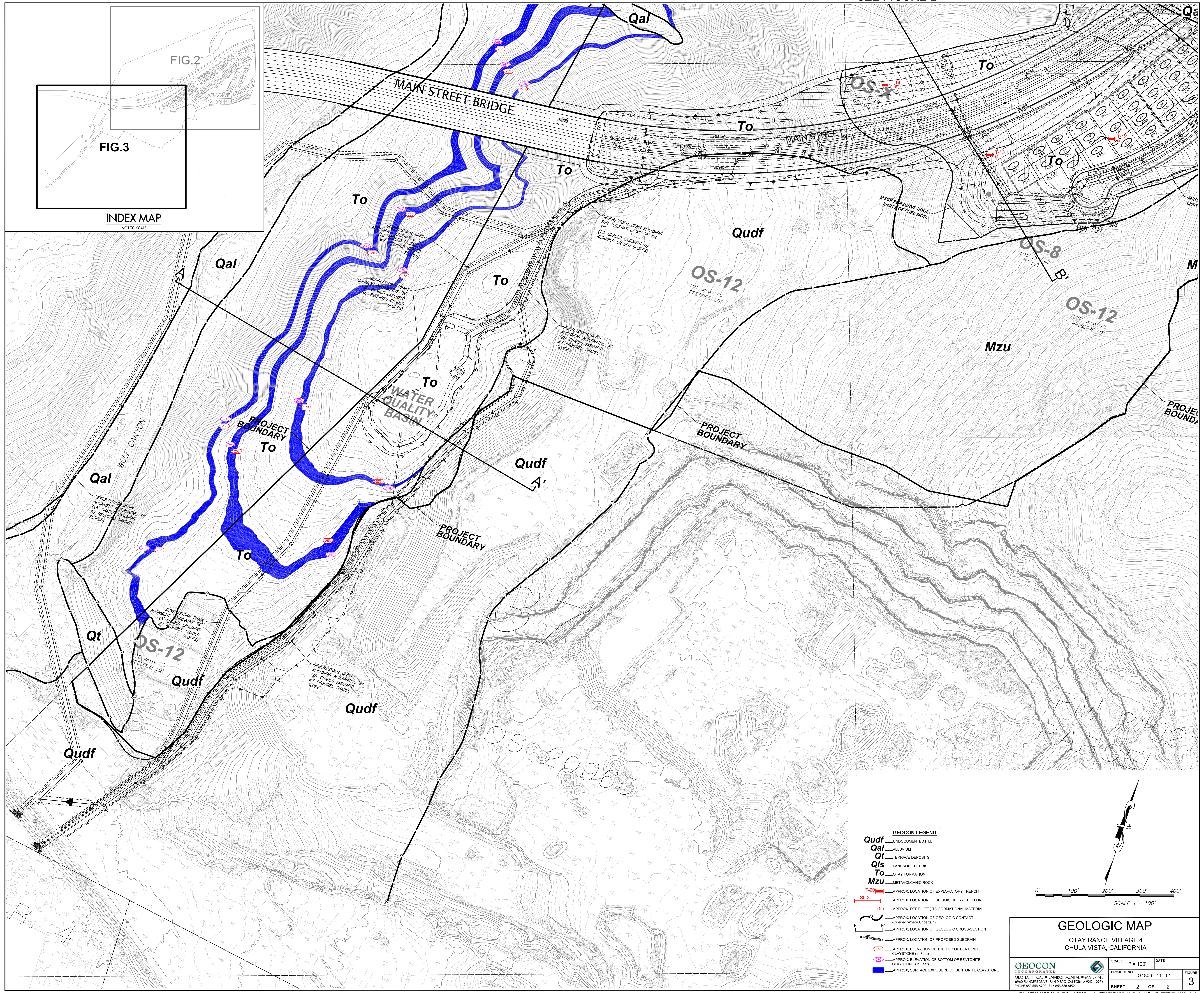

GEOCON LEGEND

- Qdf** UNDOCUMENTED FILL
- Qal** ALLUVIUM
- Qt** TERRACE DEPOSITS
- Qls** LANDSLIDE DEBRIS
- To** OTAY FORMATION
- Mzu** METAVOLCANIC ROCK
- T-20** APPROX. LOCATION OF EXPLORATORY TRENCH
- SL-3** APPROX. LOCATION OF SEISMIC REFRACTION LINE
- (S)** APPROX. DEPTH (FT.) TO FORMATIONAL MATERIAL
- F** APPROX. LOCATION OF GEOLOGIC CONTACT (Queried Where Uncertain)
- F** APPROX. LOCATION OF GEOLOGIC CROSS-SECTION
- APPROX. LOCATION OF PROPOSED SUBDRAIN
- (275)** APPROX. ELEVATION OF THE TOP OF BENTONITE CLAYSTONE (In Feet)
- (270)** APPROX. ELEVATION OF BOTTOM OF BENTONITE CLAYSTONE (In Feet)
- APPROX. SURFACE EXPOSURE OF BENTONITE CLAYSTONE

GEOLOGIC MAP
 OTAY RANCH VILLAGE 4
 CHULA VISTA, CALIFORNIA

SCALE 1" = 100' DATE _____
 PROJECT NO. G1806-11-01 FIGURE 3
 SHEET 2 OF 2

GEOCON
 INCORPORATED
 GEOTECHNICAL ■ ENVIRONMENTAL ■ MATERIALS
 6960 FLANDERS DRIVE ■ SAN DIEGO, CALIFORNIA 92121-2974
 PHONE 619-558-6900 ■ FAX 619-558-6159

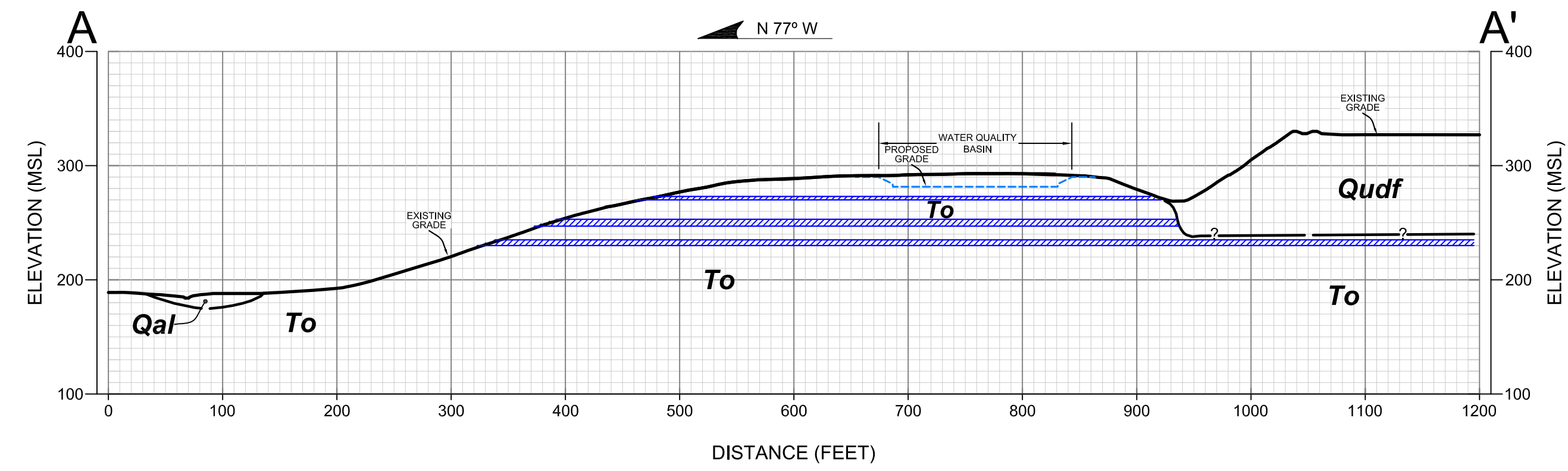

GEOLOGIC CROSS-SECTION A-A'
SCALE: 1" = 100' (Vert. = Horiz.)

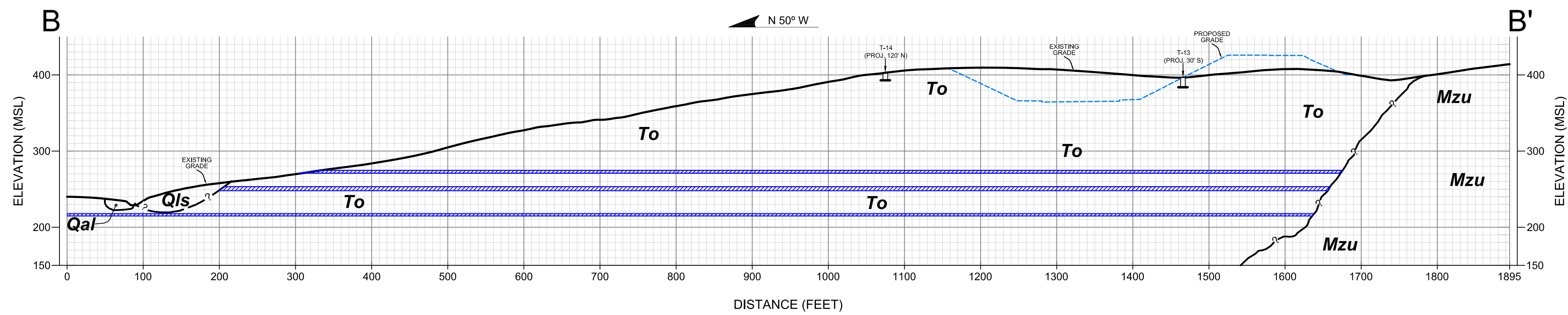

GEOLOGIC CROSS-SECTION B-B'
SCALE: 1" = 100' (Vert. = Horiz.)

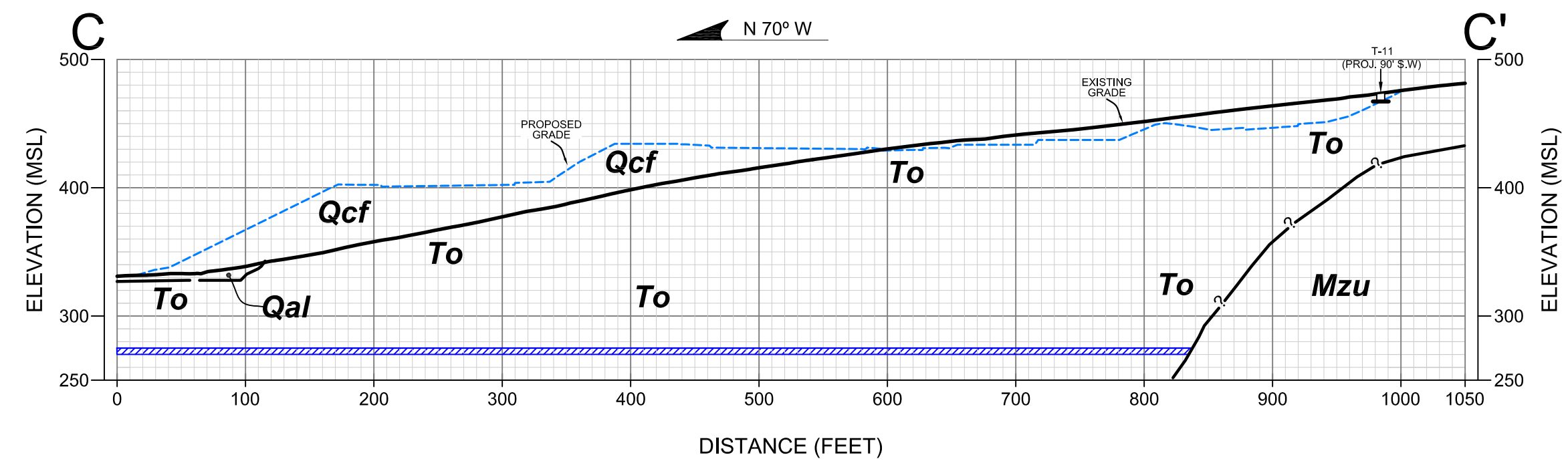

GEOLOGIC CROSS-SECTION C-C'
SCALE: 1" = 100' (Vert. = Horiz.)

- GEOCON LEGEND**
- Qudf** UNDOCUMENTED FILL
 - Qal** ALLUVIUM
 - Qls** LANDSLIDE DEBRIS
 - To** OTAY FORMATION
 - Mzu** METAVOLCANIC ROCK
 - T-14
| | APPROX. LOCATION OF EXPLORATORY TRENCH
 - APPROX. LOCATION OF BENTONITE CLAYSTONE
 - APPROX. LOCATION OF GEOLOGIC CONTACT (Queried Where Uncertain)

GEOLOGIC CROSS - SECTION		
OTAY RANCH VILLAGE 4 CHULA VISTA, CALIFORNIA		
GEOCON INCORPORATED GEOTECHNICAL ■ ENVIRONMENTAL ■ MATERIALS 6940 SANDERS DRIVE - SAN DIEGO, CALIFORNIA 92121 - 2974 PHONE 858.558-6900 • FAX 858.558-6159	SCALE 1" = 100'	DATE
	PROJECT NO. G1806 - 11 - 01	FIGURE
	SHEET 1 OF 2	4

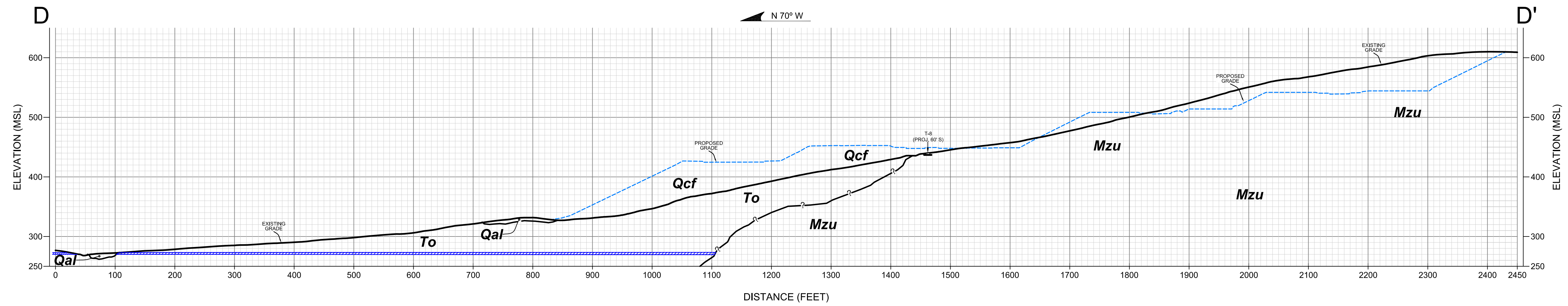

GEOLOGIC CROSS-SECTION D-D'
SCALE: 1" = 100' (Vert. = Horiz.)

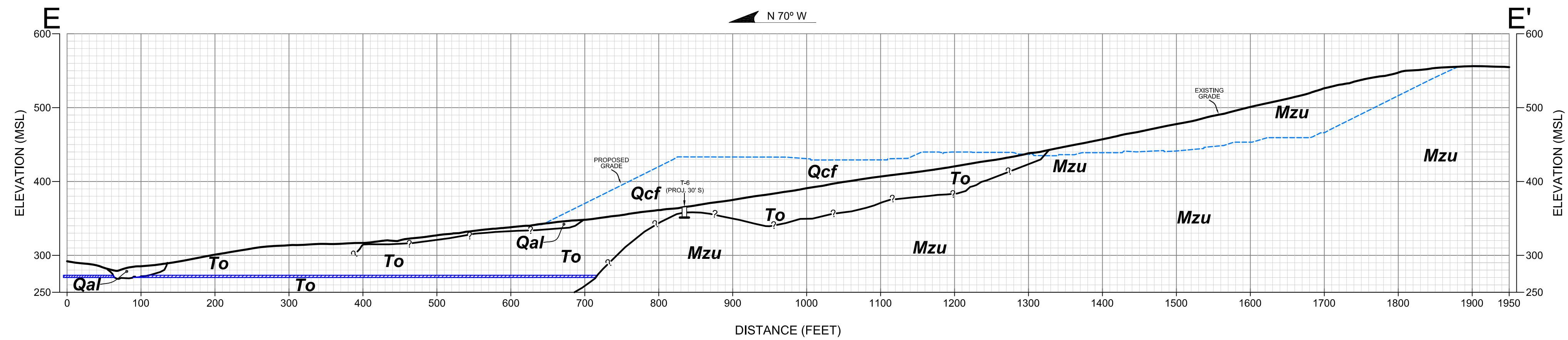

GEOLOGIC CROSS-SECTION E-E'
SCALE: 1" = 100' (Vert. = Horiz.)

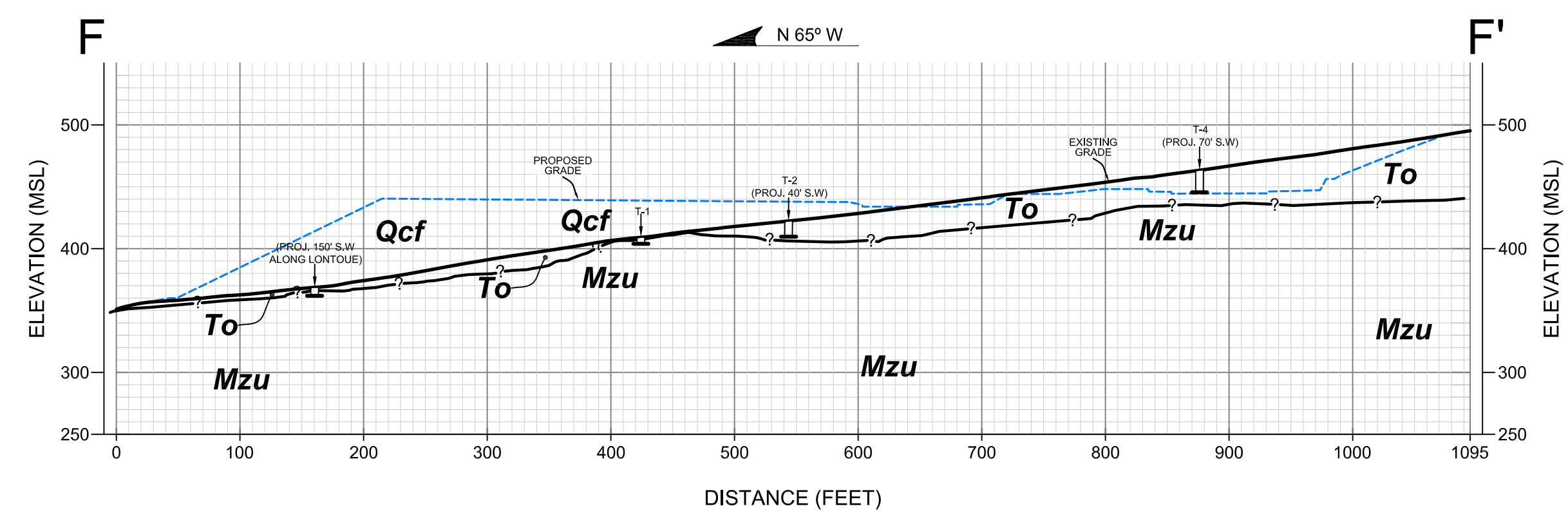

GEOLOGIC CROSS-SECTION F-F'
SCALE: 1" = 100' (Vert. = Horiz.)

- GEOCON LEGEND**
- Qudf** UNDOCUMENTED FILL
 - Qal** ALLUVIUM
 - Qls** LANDSLIDE DEBRIS
 - To** OTAY FORMATION
 - Mzu** METAVOLCANIC ROCK
 - T-S APPROX. LOCATION OF EXPLORATORY TRENCH
 - APPROX. LOCATION OF BENTONITE CLAYSTONE
 - APPROX. LOCATION OF GEOLOGIC CONTACT (Queried Where Uncertain)

GEOLOGIC CROSS - SECTION		
OTAY RANCH VILLAGE 4 CHULA VISTA, CALIFORNIA		
GEOCON INCORPORATED GEOTECHNICAL ■ ENVIRONMENTAL ■ MATERIALS 6940 SANDERS DRIVE - SAN DIEGO, CALIFORNIA 92121 - 2974 PHONE 858.558-6900 • FAX 858.558-6159	SCALE 1" = 100' PROJECT NO. G1806 - 11 - 01 SHEET 2 OF 2	DATE FIGURE 5

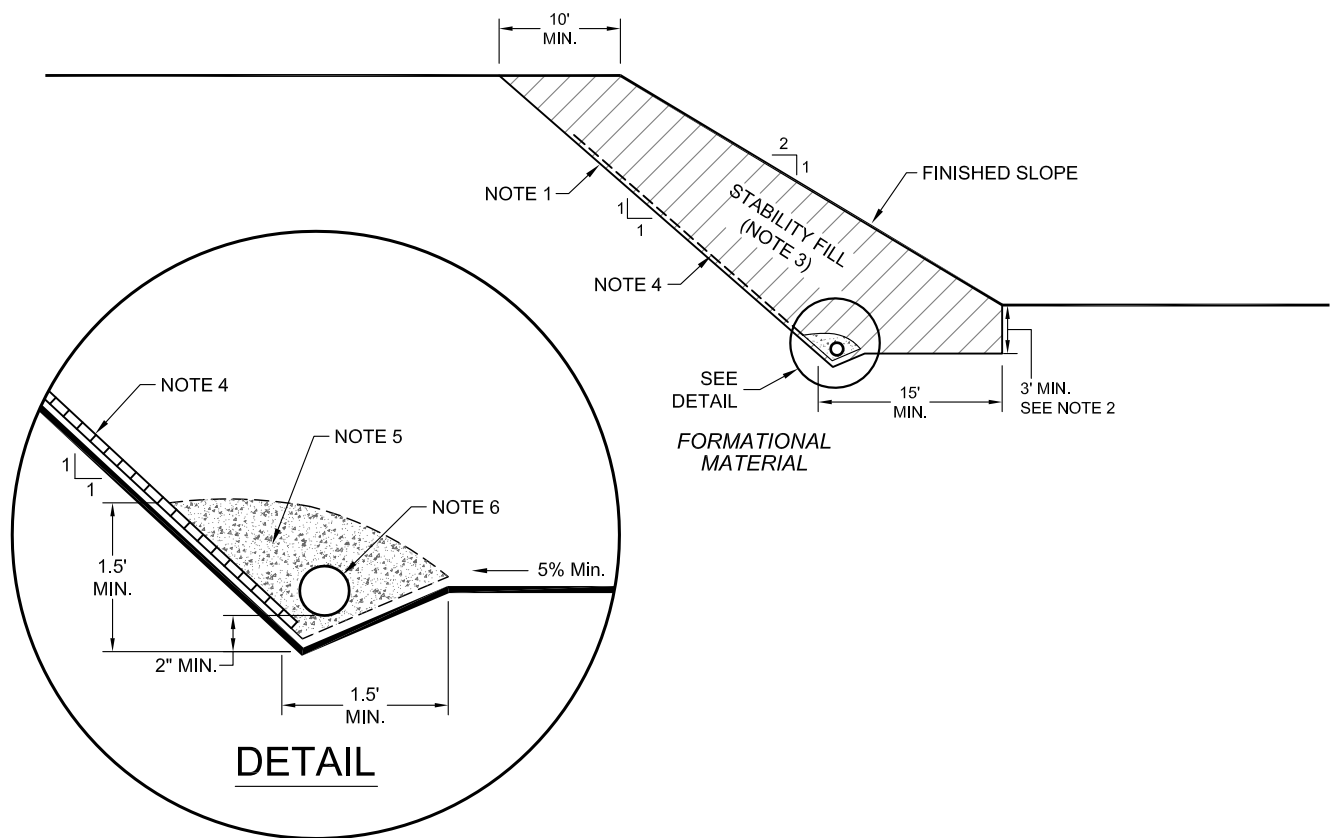

NOTES:

- 1.....EXCAVATE BACKCUT AT 1:1 INCLINATION (UNLESS OTHERWISE NOTED).
- 2.....BASE OF STABILITY FILL TO BE 3 FEET INTO FORMATIONAL MATERIAL, SLOPING A MINIMUM 5% INTO SLOPE.
- 3.....STABILITY FILL TO BE COMPOSED OF PROPERLY COMPACTED GRANULAR SOIL.
- 4.....CHIMNEY DRAINS TO BE APPROVED PREFABRICATED CHIMNEY DRAIN PANELS (MIRADRAIN G200N OR EQUIVALENT) SPACED APPROXIMATELY 20 FEET CENTER TO CENTER AND 4 FEET WIDE. CLOSER SPACING MAY BE REQUIRED IF SEEPAGE IS ENCOUNTERED.
- 5.....FILTER MATERIAL TO BE 3/4-INCH, OPEN-GRADED CRUSHED ROCK ENCLOSED IN APPROVED FILTER FABRIC (MIRAFI 140NC).
- 6.....COLLECTOR PIPE TO BE 4-INCH MINIMUM DIAMETER, PERFORATED, THICK-WALLED PVC SCHEDULE 40 OR EQUIVALENT, AND SLOPED TO DRAIN AT 1 PERCENT MINIMUM TO APPROVED OUTLET.

TYPICAL STABILITY FILL DETAIL

GEOCON
INCORPORATED



GEOTECHNICAL ■ ENVIRONMENTAL ■ MATERIALS
6960 FLANDERS DRIVE - SAN DIEGO, CALIFORNIA 92121 - 2974
PHONE 858 558-6900 - FAX 858 558-6159

OTAY RANCH VILLAGE 4
CHULA VISTA, CALIFORNIA

RM / AML

DSK/GTYPD

DATE

PROJECT NO. G1806 - 11 - 01

FIG. 6

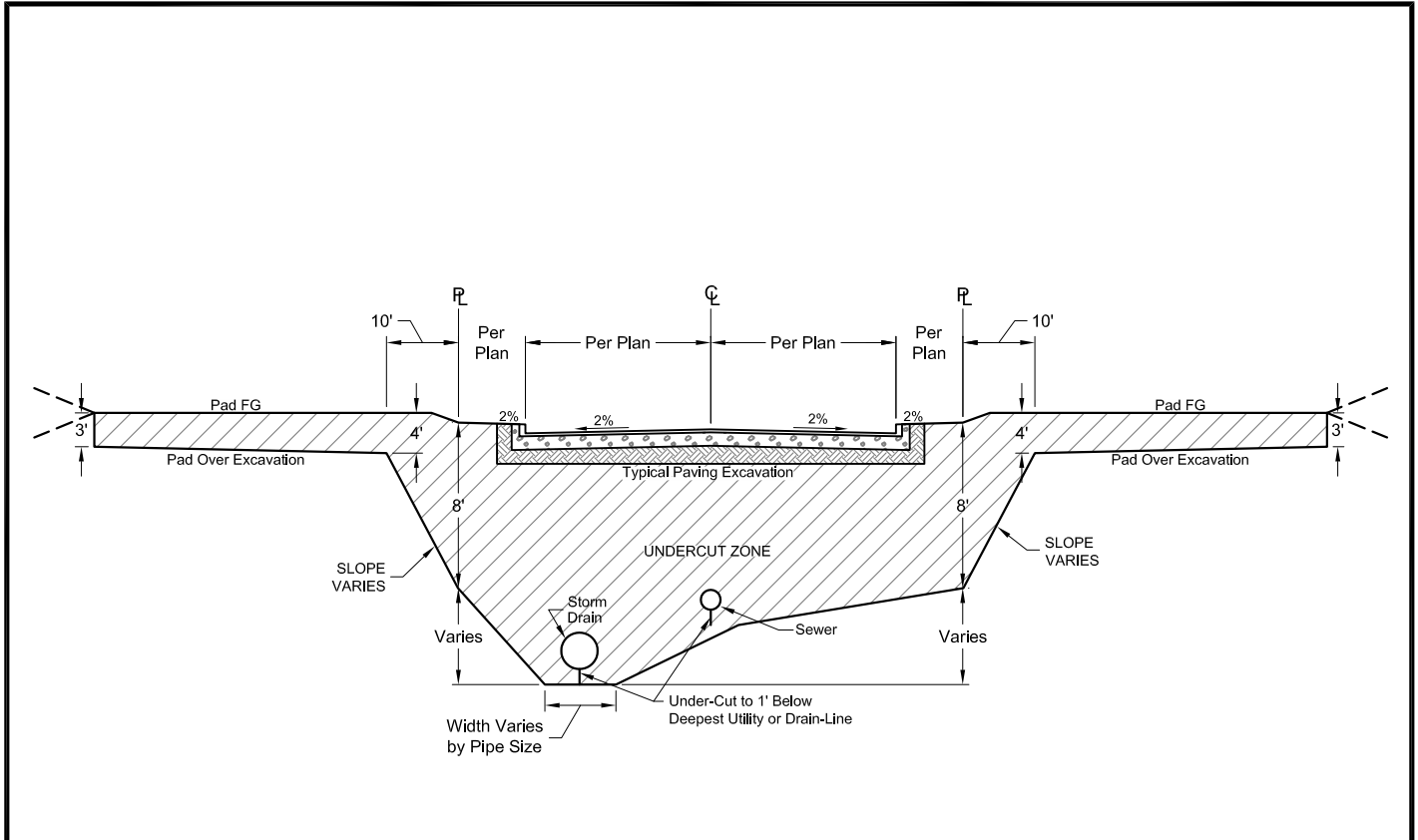

NOT TO SCALE

NOTE:
 UNDERCUT ZONE SHOULD CONTAIN COMPACTED SOIL FILL WITH
 MAXIMUM ROCK FRAGMENTS LESS THAN 6 INCHES IN DIMENSION
 AND A MINIMUM OF 40 PERCENT SOIL PASSING THE 3/4-INCH SIEVE

TYPICAL STREET OVEREXCAVATION DETAIL

GEOCON
 INCORPORATED



GEOTECHNICAL ■ ENVIRONMENTAL ■ MATERIALS
 6960 FLANDERS DRIVE - SAN DIEGO, CALIFORNIA 92121 - 2974
 PHONE 858 558-6900 - FAX 858 558-6159

OTAY RANCH VILLAGE 4
 CHULA VISTA, CALIFORNIA

RM / AML	DSK/GTYPD	DATE	PROJECT NO. G1806 - 11 - 01	FIG. 7
----------	-----------	------	-----------------------------	--------

ZONE B

WINDROWS DETAIL
(PLAN VIEW)

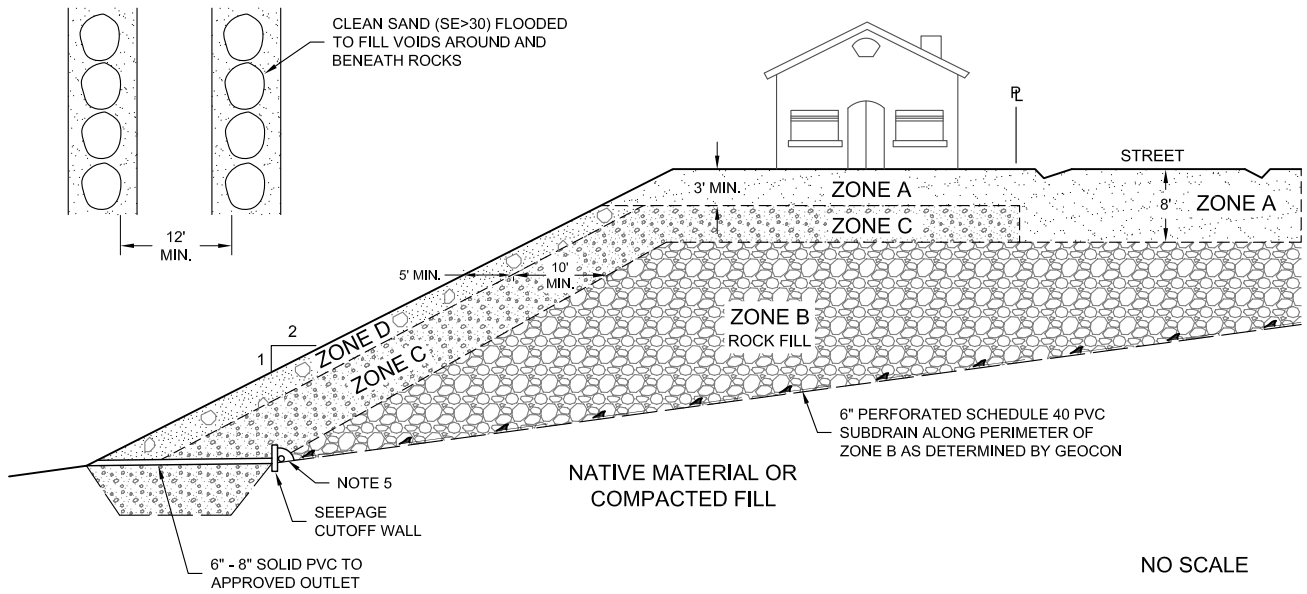

NO SCALE

LEGEND

ZONE A: COMPACTED SOIL FILL. NO ROCK FRAGMENTS OVER 6 INCHES IN DIMENSION.

ZONE B: BLASTED ROCK FILL GENERALLY CONSISTING OF 2 FOOT MINUS MATERIAL WITH OCCASIONAL INDIVIDUAL ROCK UP TO 4 FEET MAXIMUM DIMENSION
ALTERNATE: ROCKS 2 TO 4 FEET IN MAXIMUM DIMENSION CAN BE PLACED IN WINDROWS IN COMPACTED SOIL FILL POSSESSING A SAND EQUIVALENT OF AT LEAST 30.

ZONE C: ROCKS UP TO 2 FEET IN MAXIMUM DIMENSION IN A MATRIX OF COMPACTED SOIL FILL WITHIN BUILDING PADS AND SLOPE AREAS ONLY.

ZONE D: ROCKS UP TO 1 FOOT IN MAXIMUM DIMENSION IN A MATRIX OF COMPACTED SOIL FILL.

NOTES

1. COMPACTED SOIL FILL IN UPPER 8 FEET SHALL CONTAIN AT LEAST 40 PERCENT SOIL PASSING THE 3/4 - INCH SIEVE (BY WEIGHT) AND IN THE UPPER 3 FEET OF PAD GRADE AT LEAST 20% SOIL PASSING THE NO. 4 SIEVE (BY WEIGHT) AND COMPACTED IN ACCORDANCE WITH SPECIFICATIONS FOR STRUCTURAL FILL.
2. CONTINUOUS OBSERVATION REQUIRED BY GEOCON DURING ROCK PLACEMENT.
3. ROCK FILL (LESS THAN 40 PERCENT SOIL SIZES) MAY BE PERMITTED IN DESIGNATED AREAS UPON THE RECOMMENDATION OF THE GEOTECHNICAL ENGINEER.
4. DEPTH OF ZONE A SHOULD BE AT LEAST 8 FEET AND EXTENDED TO AT LEAST 2 FEET BELOW DEEPEST UTILITY WITHIN ROADWAYS.
5. 6" PERFORATED SCHEDULE 40 PVC SUBDRAIN ALONG THE TOE AND PORTIONS OF THE PERIMETER OF ZONE B.
6. BASE OF ZONE B SHOULD SLOPE A MINIMUM OF 3 PERCENT.

OVERSIZE ROCK DISPOSAL DETAIL

GEOCON
INCORPORATED



GEOTECHNICAL ■ ENVIRONMENTAL ■ MATERIALS
6960 FLANDERS DRIVE - SAN DIEGO, CALIFORNIA 92121 - 2974
PHONE 858 558-6900 - FAX 858 558-6159

OTAY RANCH VILLAGE 4
CHULA VISTA, CALIFORNIA

RM / AML

DSK/GTPD

DATE

PROJECT NO. G1806 - 11 - 01

FIG. 8

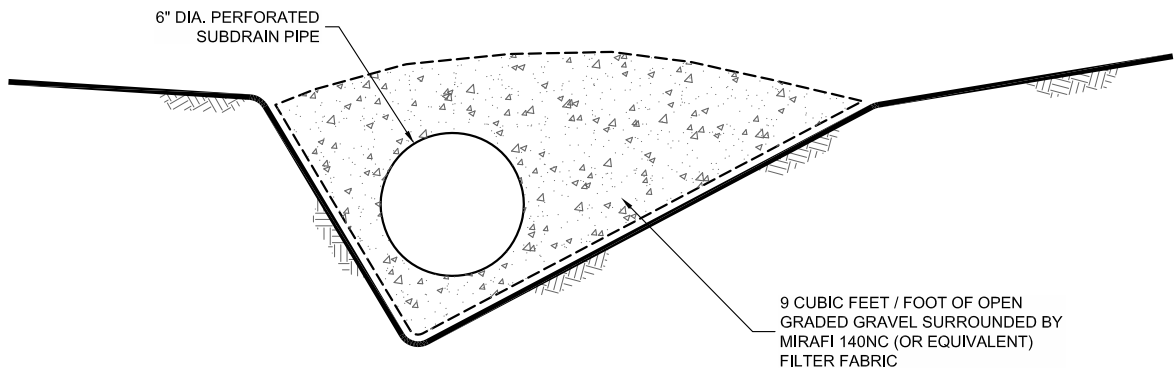
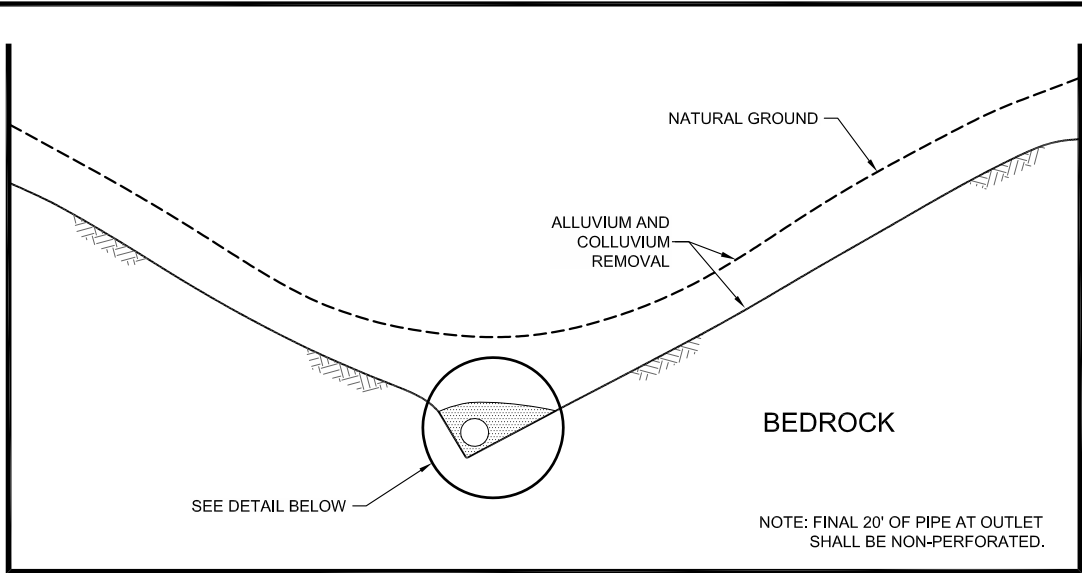

NOTES:

6-INCH DIAMETER, SCHEDULE 40 PVC PERFORATED PIPE.

NO SCALE

TYPICAL CANYON SUBDRAIN DETAIL

GEOCON
INCORPORATED



GEOTECHNICAL ■ ENVIRONMENTAL ■ MATERIALS
6960 FLANDERS DRIVE - SAN DIEGO, CALIFORNIA 92121 - 2974
PHONE 858 558-6900 - FAX 858 558-6159

OTAY RANCH VILLAGE 4
CHULA VISTA, CALIFORNIA

RM / AML

DSK/GTYPD

DATE

PROJECT NO. G1806 - 11 - 01

FIG. 9

FRONT VIEW

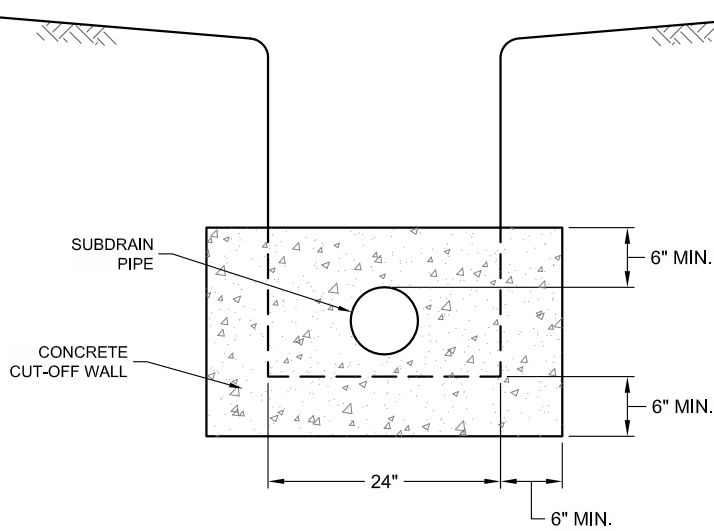

NO SCALE

SIDE VIEW

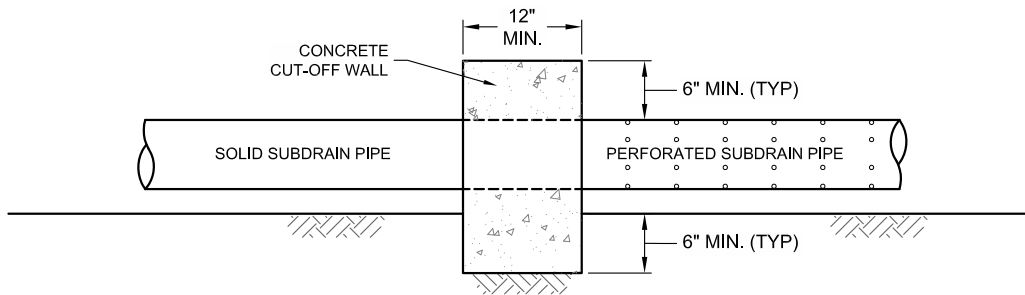

NO SCALE

RECOMMENDED SUBDRAIN CUT-OFF WALL DETAIL

GEOCON
INCORPORATED



GEOTECHNICAL ■ ENVIRONMENTAL ■ MATERIALS
6960 FLANDERS DRIVE - SAN DIEGO, CALIFORNIA 92121 - 2974
PHONE 858 558-6900 - FAX 858 558-6159

OTAY RANCH VILLAGE 4
CHULA VISTA, CALIFORNIA

RM / AML

DSK/GTYPD

DATE

PROJECT NO. G1806 - 11 - 01

FIG. 10

FRONT VIEW

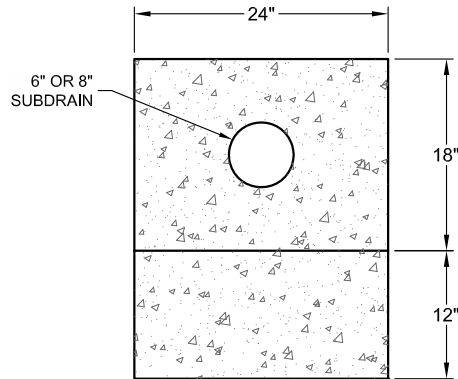

NO SCALE

SIDE VIEW

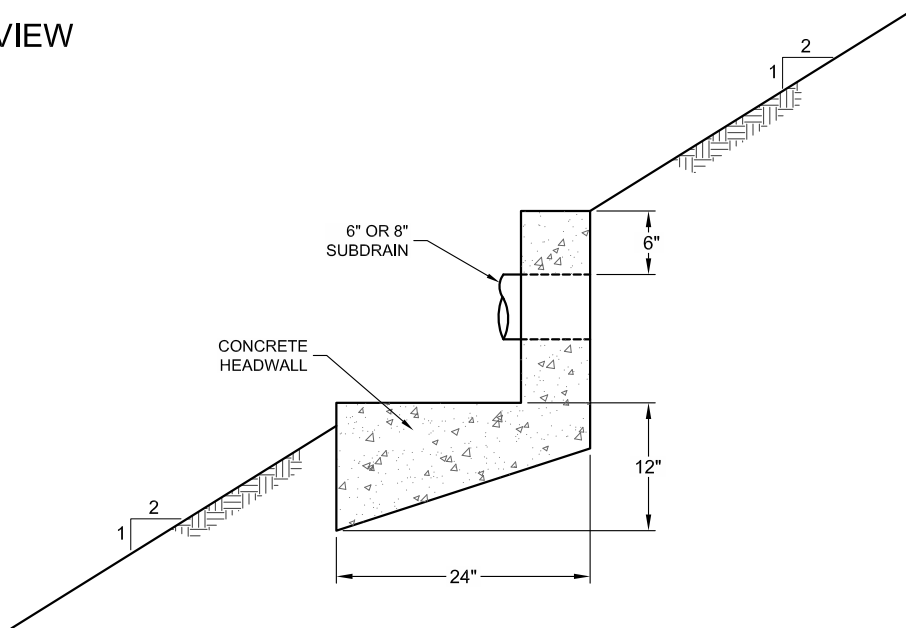

NOTE: HEADWALL SHOULD OUTLET AT TOE OF FILL SLOPE OR INTO CONTROLLED SURFACE DRAINAGE

NO SCALE

SUBDRAIN OUTLET HEADWALL DETAIL

GEOCON
INCORPORATED



GEOTECHNICAL ■ ENVIRONMENTAL ■ MATERIALS
6960 FLANDERS DRIVE - SAN DIEGO, CALIFORNIA 92121 - 2974
PHONE 858 558-6900 - FAX 858 558-6159

OTAY RANCH VILLAGE 4
CHULA VISTA, CALIFORNIA

RM / AML

DSK/GTYPD

DATE

PROJECT NO. G1806 - 11 - 01

FIG. 11

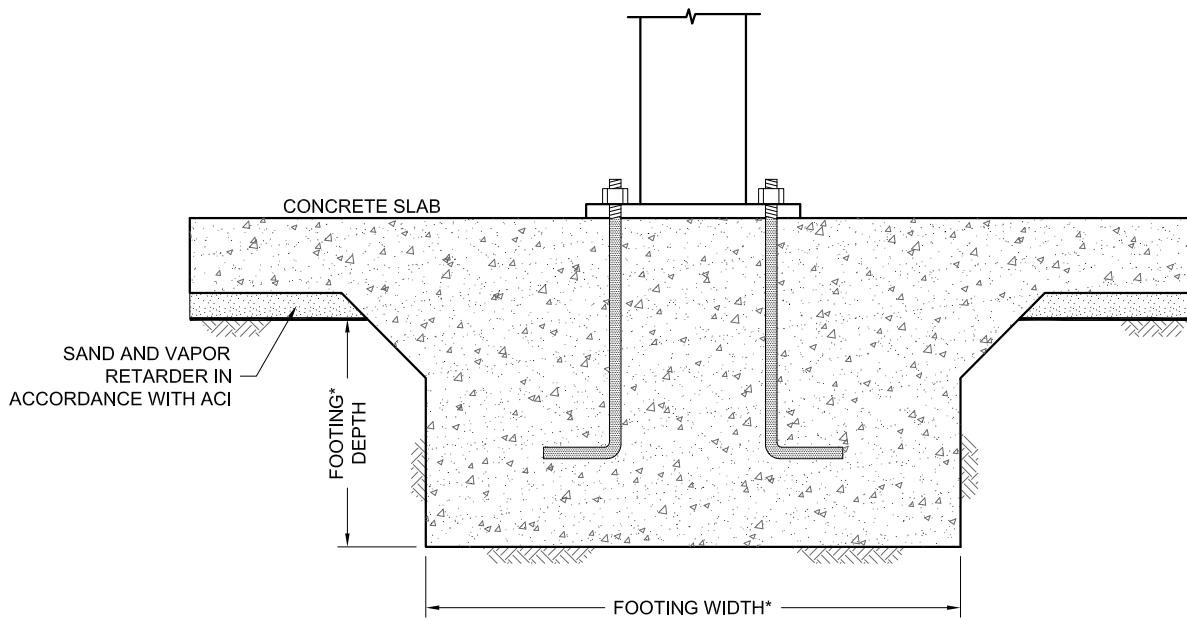
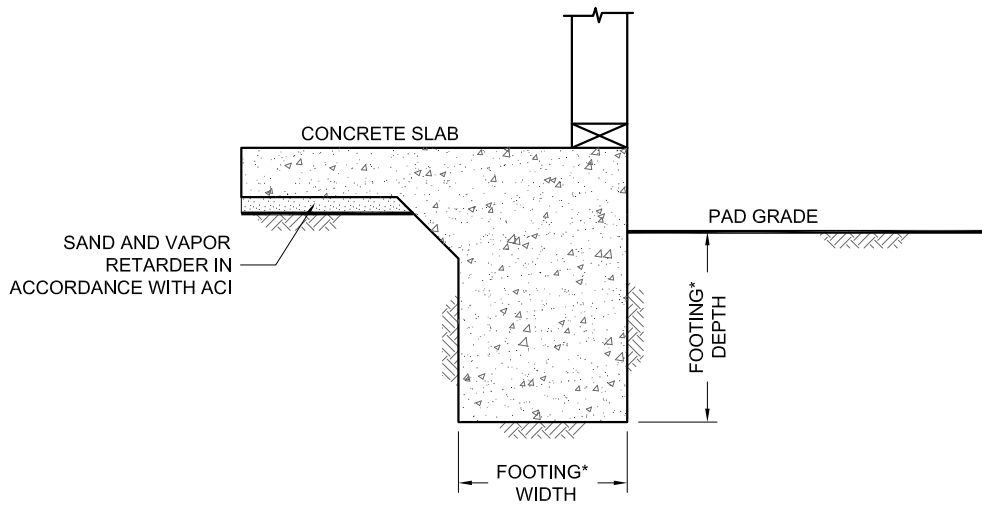

*SEE REPORT FOR FOUNDATION WIDTH AND DEPTH RECOMMENDATION

NO SCALE

WALL / COLUMN FOOTING DIMENSION DETAIL

GEOCON
INCORPORATED



GEOTECHNICAL ■ ENVIRONMENTAL ■ MATERIALS
6960 FLANDERS DRIVE - SAN DIEGO, CALIFORNIA 92121 - 2974
PHONE 858 558-6900 - FAX 858 558-6159

OTAY RANCH VILLAGE 4
CHULA VISTA, CALIFORNIA

RM / AML

DSK/GTYPD

DATE

PROJECT NO. G1806 - 11 - 01

FIG. 12

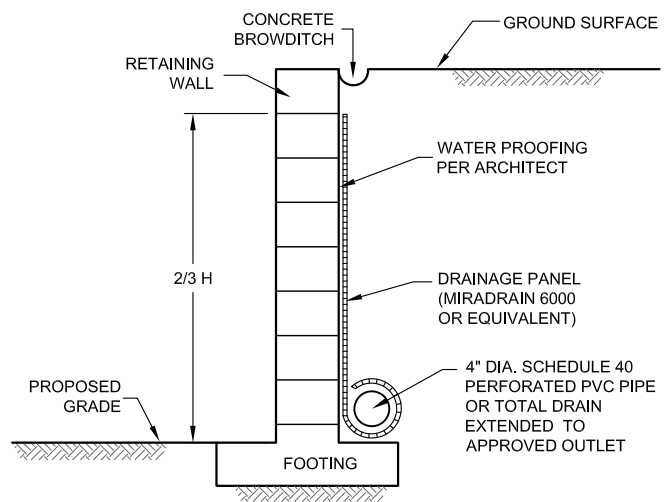
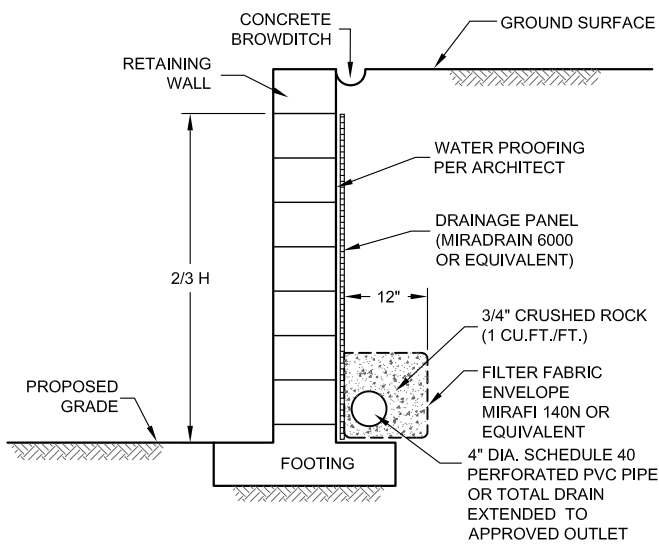
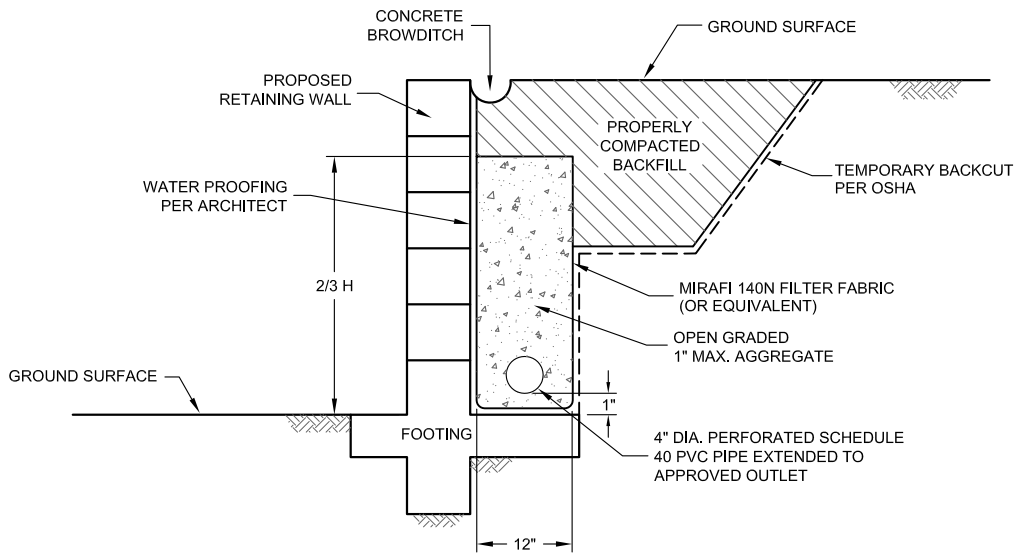

NOTE :

DRAIN SHOULD BE UNIFORMLY SLOPED TO GRAVITY OUTLET OR TO A SUMP WHERE WATER CAN BE REMOVED BY PUMPING

NO SCALE

TYPICAL RETAINING WALL DRAIN DETAIL

GEOCON
INCORPORATED



GEOTECHNICAL ■ ENVIRONMENTAL ■ MATERIALS
6960 FLANDERS DRIVE - SAN DIEGO, CALIFORNIA 92121 - 2974
PHONE 858 558-6900 - FAX 858 558-6159

OTAY RANCH VILLAGE 4
CHULA VISTA, CALIFORNIA

RM / AML

DSK/GTYPD

DATE

PROJECT NO. G1806 - 11 - 01

FIG. 13

APPENDIX

A

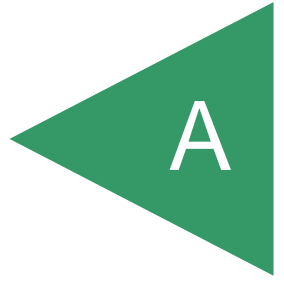

APPENDIX A

EXPLORATORY EXCAVATIONS

Our subsurface exploration consisted of excavating 20 backhoe trenches performed on February 3 and 4, 2015. We located the exploratory trenches in the field using existing readily available GPS, landmarks, trails, and drainages. The trenches were performed using a John Deere 555 trackhoe equipped with a 24-inch wide bucket and extended to a maximum depth of 17 feet. The approximate trench locations are shown on the Geologic Map (Figures 2 and 3).

We estimated elevations shown on the trench logs either from the topographic map provided by Hunsaker & Associates, San Diego. We visually examined, classified, and logged the soil conditions encountered in the borings and trenches in general conformance with the American Society for Testing and Materials (ASTM) Practice for Description and Identification of Soils (Visual - Manual Procedure D 2488). The logs of the exploratory trenches are presented on Figures A-1 through A-20 and included herein. The logs depict the various soil and rock types encountered and indicate the depths at which samples were obtained.







DEPTH IN FEET	SAMPLE NO.	LITHOLOGY	GROUNDWATER	SOIL CLASS (USCS)	TRENCH T 1		PENETRATION RESISTANCE (BLOWS/FT.)	DRY DENSITY (P.C.F.)	MOISTURE CONTENT (%)
					ELEV. (MSL.) <u>411'</u>	DATE COMPLETED <u>02-03-2015</u>			
					EQUIPMENT <u>JD 555</u> BY: <u>M. ERTWINE</u>				
					MATERIAL DESCRIPTION				
0				CL	TOPSOIL Stiff, moist, dark brown, Sandy CLAY; some gravel				
2					METAVOLCANIC ROCK (Mzu) Moderately strong, highly weathered, METAVOLCANIC ROCK; trace boulder size clasts				
4					TRENCH TERMINATED AT 4 FEET				

Figure A-1,
Log of Trench T 1, Page 1 of 1

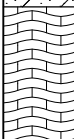
G1806-11-01.GPJ

SAMPLE SYMBOLS	 ... SAMPLING UNSUCCESSFUL	 ... STANDARD PENETRATION TEST	 ... DRIVE SAMPLE (UNDISTURBED)
	 ... DISTURBED OR BAG SAMPLE	 ... CHUNK SAMPLE	 ... WATER TABLE OR SEEPAGE

NOTE: THE LOG OF SUBSURFACE CONDITIONS SHOWN HEREON APPLIES ONLY AT THE SPECIFIC BORING OR TRENCH LOCATION AND AT THE DATE INDICATED. IT IS NOT WARRANTED TO BE REPRESENTATIVE OF SUBSURFACE CONDITIONS AT OTHER LOCATIONS AND TIMES.







DEPTH IN FEET	SAMPLE NO.	LITHOLOGY	GROUNDWATER	SOIL CLASS (USCS)	TRENCH T 2		PENETRATION RESISTANCE (BLOWS/FT.)	DRY DENSITY (P.C.F.)	MOISTURE CONTENT (%)
					ELEV. (MSL.) <u>426'</u>	DATE COMPLETED <u>02-03-2015</u>			
					EQUIPMENT <u>JD 555</u> BY: <u>M. ERTWINE</u>				
MATERIAL DESCRIPTION									
0				SC	TOPSOIL Loose, brown, Clayey SAND; trace rootlets				
				CL	Stiff, moist, dark brown, Sandy CLAY; blocky structure, trace rootlets				
2	T2-1								
				ML	OTAY FORMATION (To) Medium dense, dry, whitish gray, Sandy SILTSTONE; abundant carbonates				
4					-Becomes dense				
6	T2-2								
8				SM	Very dense, damp, light grayish brown, Silty SANDSTONE; some gravel clasts				
10					-Abundant clasts of metavolcanic rock within matrix				
12					REFUSAL AT 12 FEET				

Figure A-2,
Log of Trench T 2, Page 1 of 1

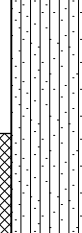
G1806-11-01.GPJ

SAMPLE SYMBOLS		... SAMPLING UNSUCCESSFUL		... STANDARD PENETRATION TEST		... DRIVE SAMPLE (UNDISTURBED)
		... DISTURBED OR BAG SAMPLE		... CHUNK SAMPLE		... WATER TABLE OR SEEPAGE

NOTE: THE LOG OF SUBSURFACE CONDITIONS SHOWN HEREON APPLIES ONLY AT THE SPECIFIC BORING OR TRENCH LOCATION AND AT THE DATE INDICATED. IT IS NOT WARRANTED TO BE REPRESENTATIVE OF SUBSURFACE CONDITIONS AT OTHER LOCATIONS AND TIMES.

DEPTH IN FEET	SAMPLE NO.	LITHOLOGY	GROUNDWATER	SOIL CLASS (USCS)	TRENCH T 3		PENETRATION RESISTANCE (BLOWS/FT.)	DRY DENSITY (P.C.F.)	MOISTURE CONTENT (%)
					ELEV. (MSL.) <u>381'</u>	DATE COMPLETED <u>02-03-2015</u>			
					EQUIPMENT <u>JD 555</u>		BY: <u>M. ERTWINE</u>		
MATERIAL DESCRIPTION									
0	T3-1			CL	COLLUVIUM (Qc) Stiff, moist, brown, Sandy CLAY; abundant carbonates, blocky texture, carbonates infilled				
2				GP	OTAY FORMATION (To) Very dense, moist, brown, Sandy GRAVEL, sandstone matrix				
4					METAVOLCANIC ROCK (Mzu) Highly weathered, dark gray, moderately strong, METAVOLCANIC ROCK				
6	REFUSAL AT 6 FEET								

Figure A-3,
Log of Trench T 3, Page 1 of 1

G1806-11-01.GPJ

SAMPLE SYMBOLS	... SAMPLING UNSUCCESSFUL	... STANDARD PENETRATION TEST	... DRIVE SAMPLE (UNDISTURBED)
	... DISTURBED OR BAG SAMPLE	... CHUNK SAMPLE	... WATER TABLE OR SEEPAGE

NOTE: THE LOG OF SUBSURFACE CONDITIONS SHOWN HEREON APPLIES ONLY AT THE SPECIFIC BORING OR TRENCH LOCATION AND AT THE DATE INDICATED. IT IS NOT WARRANTED TO BE REPRESENTATIVE OF SUBSURFACE CONDITIONS AT OTHER LOCATIONS AND TIMES.

DEPTH IN FEET	SAMPLE NO.	LITHOLOGY	GROUNDWATER	SOIL CLASS (USCS)	TRENCH T 4		PENETRATION RESISTANCE (BLOWS/FT.)	DRY DENSITY (P.C.F.)	MOISTURE CONTENT (%)
					ELEV. (MSL.) 467'	DATE COMPLETED 02-03-2015			
					EQUIPMENT JD 555		BY: M. ERTWINE		
MATERIAL DESCRIPTION									
0				SC	TOPSOIL Stiff, moist, brown, Sandy CLAY				
2				SM	OTAY FORMATION (T_o) Medium dense, dry, whitish gray, Silty, fine-grained SANDSTONE; weakly cemented, abundant carbonates -Becomes dense, moderately cemented				
4									
6	T4-1			ML	Hard, moist, Clayey, SILTSTONE, trace clasts of fine gravel within matrix				
8	T4-2			SM	Dense, moist, gray, Silty, fine-grained SANDSTONE, moderately cemented, trace clasts of gravel -Excavates with moderate to heavy effort -Becomes very dense, grayish brown, some (20%-50%) gravel, clasts of metavolcanic rock				
10									
12									
14					REFUSAL AT 14 FEET				

Figure A-4,
Log of Trench T 4, Page 1 of 1

G1806-11-01.GPJ

SAMPLE SYMBOLS		... SAMPLING UNSUCCESSFUL		... STANDARD PENETRATION TEST		... DRIVE SAMPLE (UNDISTURBED)
		... DISTURBED OR BAG SAMPLE		... CHUNK SAMPLE		... WATER TABLE OR SEEPAGE

NOTE: THE LOG OF SUBSURFACE CONDITIONS SHOWN HEREON APPLIES ONLY AT THE SPECIFIC BORING OR TRENCH LOCATION AND AT THE DATE INDICATED. IT IS NOT WARRANTED TO BE REPRESENTATIVE OF SUBSURFACE CONDITIONS AT OTHER LOCATIONS AND TIMES.







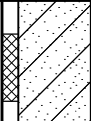
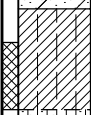

DEPTH IN FEET	SAMPLE NO.	LITHOLOGY	GROUNDWATER	SOIL CLASS (USCS)	TRENCH T 5		PENETRATION RESISTANCE (BLOWS/FT.)	DRY DENSITY (P.C.F.)	MOISTURE CONTENT (%)
					ELEV. (MSL.) <u>505'</u>	DATE COMPLETED <u>02-03-2015</u>			
					EQUIPMENT <u>JD 555</u>		BY: <u>M. ERTWINE</u>		
MATERIAL DESCRIPTION									
0	T5-1			CL	TOPSOIL Soft, moist, dark brown, Sandy CLAY; few rootlets, trace carbonates				
2	T5-2			CL	OTAY FORMATION (To) Medium stiff, moist, brown, Silty CLAYSTONE; blocky texture				
4				ML	Hard, moist, dark brown, Sandy SILTSTONE				
6				SM	Dense, moist, whitish gray, Silty, fine-grained SANDSTONE; moderately cemented -Trace clasts of gravel derived from metavolcanic rock -Difficult excavation -Massive, becomes well cemented				
14					-Becomes sandy gravel, some clasts of metavolcanic rock				
REFUSAL AT 15 FEET									

Figure A-5,
Log of Trench T 5, Page 1 of 1

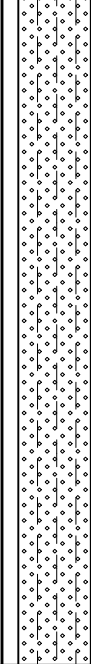
G1806-11-01.GPJ







SAMPLE SYMBOLS	 ... SAMPLING UNSUCCESSFUL	 ... STANDARD PENETRATION TEST	 ... DRIVE SAMPLE (UNDISTURBED)
	 ... DISTURBED OR BAG SAMPLE	 ... CHUNK SAMPLE	 ... WATER TABLE OR SEEPAGE

NOTE: THE LOG OF SUBSURFACE CONDITIONS SHOWN HEREON APPLIES ONLY AT THE SPECIFIC BORING OR TRENCH LOCATION AND AT THE DATE INDICATED. IT IS NOT WARRANTED TO BE REPRESENTATIVE OF SUBSURFACE CONDITIONS AT OTHER LOCATIONS AND TIMES.

DEPTH IN FEET	SAMPLE NO.	LITHOLOGY	GROUNDWATER	SOIL CLASS (USCS)	TRENCH T 6		PENETRATION RESISTANCE (BLOWS/FT.)	DRY DENSITY (P.C.F.)	MOISTURE CONTENT (%)
					ELEV. (MSL.) <u>372'</u>	DATE COMPLETED <u>02-03-2015</u>			
					EQUIPMENT <u>JD 555</u>		BY: <u>M. ERTWINE</u>		
MATERIAL DESCRIPTION									
0				SC	ALLUVIUM (Qal) Loose, dry, light olive to yellowish brown, Clayey SAND; few gravel clasts				
2					-Becomes medium dense, brown to grayish brown				
4									
6				SC	OTAY FORMATION (To) Dense, moist, reddish brown, Clayey, fine-grained SANDSTONE				
8	T6-1			ML	Hard, moist, yellowish brown, Clayey SILT; excavates blocky with trace gravel clasts				
10	T6-2				METAVOLCANIC ROCK (Mzu) Completely weathered, weak, coarse gravel, little sand, decomposed, soft METAVOLCANIC ROCK				
12					-Excavates to a clayey sand with some gravel				
14					Completely weathered, pale yellowish orange, decomposed, moderately soft, METAVOLCANIC ROCK; excavates to clayey sand with some gravel				
16					-Massive				
					TRENCH TERMINATED AT 17 FEET				

Figure A-6,
Log of Trench T 6, Page 1 of 1

G1806-11-01.GPJ

SAMPLE SYMBOLS	 ... SAMPLING UNSUCCESSFUL	 ... STANDARD PENETRATION TEST	 ... DRIVE SAMPLE (UNDISTURBED)
	 ... DISTURBED OR BAG SAMPLE	 ... CHUNK SAMPLE	 ... WATER TABLE OR SEEPAGE

NOTE: THE LOG OF SUBSURFACE CONDITIONS SHOWN HEREON APPLIES ONLY AT THE SPECIFIC BORING OR TRENCH LOCATION AND AT THE DATE INDICATED. IT IS NOT WARRANTED TO BE REPRESENTATIVE OF SUBSURFACE CONDITIONS AT OTHER LOCATIONS AND TIMES.







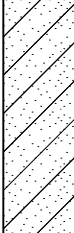

DEPTH IN FEET	SAMPLE NO.	LITHOLOGY	GROUNDWATER	SOIL CLASS (USCS)	TRENCH T 7		PENETRATION RESISTANCE (BLOWS/FT.)	DRY DENSITY (P.C.F.)	MOISTURE CONTENT (%)
					ELEV. (MSL.) 454'	DATE COMPLETED 02-03-2015			
					EQUIPMENT JD 555 BY: M. ERTWINE				
MATERIAL DESCRIPTION									
0				CL	TOPSOIL Stiff, moist, brown, Sandy CLAY -Blocky texture; carbonate infilled -Becomes very stiff; trace gravel				
2									
4				SM	OTAY FORMATION (To) Medium dense, dry, whitish brown, Silty, fine-grained SANDSTONE; abundant carbonates, weakly cemented -Becomes dense, moderately cemented, some clasts of gravel derived from metavolcanic rock -Difficult excavation, becomes well cemented				
6									
8									
10				GP	Very dense, grayish brown, Sandy GRAVEL; few boulder sized clasts				
					REFUSAL AT 10 FEET				

Figure A-7,
Log of Trench T 7, Page 1 of 1

G1806-11-01.GPJ

SAMPLE SYMBOLS		... SAMPLING UNSUCCESSFUL		... STANDARD PENETRATION TEST		... DRIVE SAMPLE (UNDISTURBED)
		... DISTURBED OR BAG SAMPLE		... CHUNK SAMPLE		... WATER TABLE OR SEEPAGE

NOTE: THE LOG OF SUBSURFACE CONDITIONS SHOWN HEREON APPLIES ONLY AT THE SPECIFIC BORING OR TRENCH LOCATION AND AT THE DATE INDICATED. IT IS NOT WARRANTED TO BE REPRESENTATIVE OF SUBSURFACE CONDITIONS AT OTHER LOCATIONS AND TIMES.









DEPTH IN FEET	SAMPLE NO.	LITHOLOGY	GROUNDWATER	SOIL CLASS (USCS)	TRENCH T 8		PENETRATION RESISTANCE (BLOWS/FT.)	DRY DENSITY (P.C.F.)	MOISTURE CONTENT (%)
					ELEV. (MSL.) <u>430'</u>	DATE COMPLETED <u>02-03-2015</u>			
					EQUIPMENT <u>JD 555</u> BY: <u>M. ERTWINE</u>				
					MATERIAL DESCRIPTION				
0				CL	TOPSOIL Stiff, moist, dark brown, Sandy CLAY				
2					METAVOLCANIC ROCK (Mzu) Black to dusky brown, highly weathered, strong METAVOLCANIC ROCK; moderately fractured				
					REFUSAL AT 3 FEET				

Figure A-8,
Log of Trench T 8, Page 1 of 1

G1806-11-01.GPJ

SAMPLE SYMBOLS	 ... SAMPLING UNSUCCESSFUL	 ... STANDARD PENETRATION TEST	 ... DRIVE SAMPLE (UNDISTURBED)
	 ... DISTURBED OR BAG SAMPLE	 ... CHUNK SAMPLE	 ... WATER TABLE OR SEEPAGE

NOTE: THE LOG OF SUBSURFACE CONDITIONS SHOWN HEREON APPLIES ONLY AT THE SPECIFIC BORING OR TRENCH LOCATION AND AT THE DATE INDICATED. IT IS NOT WARRANTED TO BE REPRESENTATIVE OF SUBSURFACE CONDITIONS AT OTHER LOCATIONS AND TIMES.









DEPTH IN FEET	SAMPLE NO.	LITHOLOGY	GROUNDWATER	SOIL CLASS (USCS)	TRENCH T 9		PENETRATION RESISTANCE (BLOWS/FT.)	DRY DENSITY (P.C.F.)	MOISTURE CONTENT (%)
					ELEV. (MSL.) <u>500'</u>	DATE COMPLETED <u>02-03-2015</u>			
					EQUIPMENT <u>JD 555</u>		BY: <u>M. ERTWINE</u>		
MATERIAL DESCRIPTION									
0				CL	TOPSOIL Medium stiff, moist, brown, Sandy CLAY				
2					-Becomes stiff				
4				SM	OTAY FORMATION (To) Dense, moist, whitish gray, Silty, fine-grained SANDSTONE				
6					-Excavates blocky, highly weathered				
8					-Becomes moderately cemented				
10					-Massive				
					-Abundant gravel within matrix, well cemented				
REFUSAL AT 11 FEET									

Figure A-9,
Log of Trench T 9, Page 1 of 1

G1806-11-01.GPJ

SAMPLE SYMBOLS		... SAMPLING UNSUCCESSFUL		... STANDARD PENETRATION TEST		... DRIVE SAMPLE (UNDISTURBED)
		... DISTURBED OR BAG SAMPLE		... CHUNK SAMPLE		... WATER TABLE OR SEEPAGE

NOTE: THE LOG OF SUBSURFACE CONDITIONS SHOWN HEREON APPLIES ONLY AT THE SPECIFIC BORING OR TRENCH LOCATION AND AT THE DATE INDICATED. IT IS NOT WARRANTED TO BE REPRESENTATIVE OF SUBSURFACE CONDITIONS AT OTHER LOCATIONS AND TIMES.







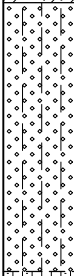

DEPTH IN FEET	SAMPLE NO.	LITHOLOGY	GROUNDWATER	SOIL CLASS (USCS)	TRENCH T 10		PENETRATION RESISTANCE (BLOWS/FT.)	DRY DENSITY (P.C.F.)	MOISTURE CONTENT (%)
					ELEV. (MSL.) <u>517'</u>	DATE COMPLETED <u>02-03-2015</u>			
					EQUIPMENT <u>JD 555</u>		BY: <u>M. ERTWINE</u>		
MATERIAL DESCRIPTION									
0				SC	TOPSOIL Medium stiff, moist, dark brown, Sandy CLAY				
2				SM	OTAY FORMATION (To) Medium dense, dry, whitish gray, Silty, fine-grained SANDSTONE; weakly cemented -Becomes dense -Trace gravel clasts				
4									
6				ML	Hard, moist, grayish brown, Sandy SILTSTONE -Massive -Difficult excavation -Trace clasts of fine gravel within siltstone matrix				
8									
10									
12									
14									
16									
REFUSAL AT 17 FEET									

Figure A-10,
Log of Trench T 10, Page 1 of 1

G1806-11-01.GPJ

SAMPLE SYMBOLS	 ... SAMPLING UNSUCCESSFUL	 ... STANDARD PENETRATION TEST	 ... DRIVE SAMPLE (UNDISTURBED)
	 ... DISTURBED OR BAG SAMPLE	 ... CHUNK SAMPLE	 ... WATER TABLE OR SEEPAGE

NOTE: THE LOG OF SUBSURFACE CONDITIONS SHOWN HEREON APPLIES ONLY AT THE SPECIFIC BORING OR TRENCH LOCATION AND AT THE DATE INDICATED. IT IS NOT WARRANTED TO BE REPRESENTATIVE OF SUBSURFACE CONDITIONS AT OTHER LOCATIONS AND TIMES.







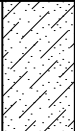
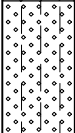

DEPTH IN FEET	SAMPLE NO.	LITHOLOGY	GROUNDWATER	SOIL CLASS (USCS)	TRENCH T 11		PENETRATION RESISTANCE (BLOWS/FT.)	DRY DENSITY (P.C.F.)	MOISTURE CONTENT (%)	
					ELEV. (MSL.) 475'	DATE COMPLETED 02-04-2015				
					EQUIPMENT JD 555 BY: M. ERTWINE					
					MATERIAL DESCRIPTION					
0				SC	TOPSOIL Loose, moist, dark brown, Clayey SAND; trace carbonates					
2				SM	OTAY FORMATION (To) Medium dense, dry, whitish gray, Silty, fine-grained SANDSTONE; weakly cemented, abundant carbonates					
4				SP	Dense, moist, light grayish brown, fine-grained SANDSTONE; moderately cemented					
6										
8										
10					-Becomes very dense, well cemented					
					REFUSAL AT 11 FEET					

Figure A-11,
Log of Trench T 11, Page 1 of 1

G1806-11-01.GPJ

SAMPLE SYMBOLS	 ... SAMPLING UNSUCCESSFUL	 ... STANDARD PENETRATION TEST	 ... DRIVE SAMPLE (UNDISTURBED)
	 ... DISTURBED OR BAG SAMPLE	 ... CHUNK SAMPLE	 ... WATER TABLE OR SEEPAGE

NOTE: THE LOG OF SUBSURFACE CONDITIONS SHOWN HEREON APPLIES ONLY AT THE SPECIFIC BORING OR TRENCH LOCATION AND AT THE DATE INDICATED. IT IS NOT WARRANTED TO BE REPRESENTATIVE OF SUBSURFACE CONDITIONS AT OTHER LOCATIONS AND TIMES.









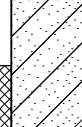
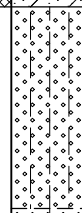

DEPTH IN FEET	SAMPLE NO.	LITHOLOGY	GROUNDWATER	SOIL CLASS (USCS)	TRENCH T 12		PENETRATION RESISTANCE (BLOWS/FT.)	DRY DENSITY (P.C.F.)	MOISTURE CONTENT (%)
					ELEV. (MSL.) <u>427'</u>	DATE COMPLETED <u>02-04-2015</u>			
					EQUIPMENT <u>JD 555</u> BY: <u>M. ERTWINE</u>				
MATERIAL DESCRIPTION									
0	T12-1			CL	TOPSOIL Stiff, moist, brown, Sandy CLAY; some rootlets				
2				SM	OTAY FORMATION (To) Medium dense, moist, light gray to whitish, Silty, fine-grained SANDSTONE; weakly cemented				
4	T12-2			SM-SC	-Becomes dense -Becomes moderately cemented Very dense, moist, brown, Silty to Clayey, fine to medium-grained SANDSTONE; trace gravel				
6				GP	Very dense, most, gray, Sandy GRAVEL; clasts of metavolcanic rock within matrix, difficult excavation				
8					-Thickly bedded, well cemented				
10									
REFUSAL AT 11 FEET									

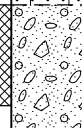
Figure A-12,
Log of Trench T 12, Page 1 of 1

G1806-11-01.GPJ

SAMPLE SYMBOLS		... SAMPLING UNSUCCESSFUL		... STANDARD PENETRATION TEST		... DRIVE SAMPLE (UNDISTURBED)
		... DISTURBED OR BAG SAMPLE		... CHUNK SAMPLE		... WATER TABLE OR SEEPAGE

NOTE: THE LOG OF SUBSURFACE CONDITIONS SHOWN HEREON APPLIES ONLY AT THE SPECIFIC BORING OR TRENCH LOCATION AND AT THE DATE INDICATED. IT IS NOT WARRANTED TO BE REPRESENTATIVE OF SUBSURFACE CONDITIONS AT OTHER LOCATIONS AND TIMES.

DEPTH IN FEET	SAMPLE NO.	LITHOLOGY	GROUNDWATER	SOIL CLASS (USCS)	TRENCH T 13		PENETRATION RESISTANCE (BLOWS/FT.)	DRY DENSITY (P.C.F.)	MOISTURE CONTENT (%)
					ELEV. (MSL.) <u>403'</u>	DATE COMPLETED <u>02-04-2015</u>			
					EQUIPMENT <u>JD 555</u> BY: <u>M. ERTWINE</u>				
					MATERIAL DESCRIPTION				
0				SC	TOPSOIL Loose, moist, brown, Clayey SAND				
2				SM	Medium dense, whitish gray, Silty, fine-grained SANDSTONE; porous, weakly cemented, abundant carbonates, trace krotovinas				
4	T13-1			SM	OTAY FORMATION (To) Dense, moist, gray, Silty, fine-to coarse grained SANDSTONE; ("Gritstone"), moderately cemented, few gravel clasts				
6					-Becomes very dense, dry, yellowish gray, fine-grained; well cemented				
8					-Massive				
10									
12					-Becomes sandy gravel, some clasts of gravel derived from metavolcanic rock, difficult excavation, clast up to 6-inches				
14	T13-2				REFUSAL AT 14 FEET				

Figure A-13,
Log of Trench T 13, Page 1 of 1

G1806-11-01.GPJ

SAMPLE SYMBOLS		... SAMPLING UNSUCCESSFUL		... STANDARD PENETRATION TEST		... DRIVE SAMPLE (UNDISTURBED)
		... DISTURBED OR BAG SAMPLE		... CHUNK SAMPLE		... WATER TABLE OR SEEPAGE

NOTE: THE LOG OF SUBSURFACE CONDITIONS SHOWN HEREON APPLIES ONLY AT THE SPECIFIC BORING OR TRENCH LOCATION AND AT THE DATE INDICATED. IT IS NOT WARRANTED TO BE REPRESENTATIVE OF SUBSURFACE CONDITIONS AT OTHER LOCATIONS AND TIMES.









DEPTH IN FEET	SAMPLE NO.	LITHOLOGY	GROUNDWATER	SOIL CLASS (USCS)	TRENCH T 14		PENETRATION RESISTANCE (BLOWS/FT.)	DRY DENSITY (P.C.F.)	MOISTURE CONTENT (%)
					ELEV. (MSL.) 404'	DATE COMPLETED 02-04-2015			
					EQUIPMENT JD 555 BY: M. ERTWINE				
					MATERIAL DESCRIPTION				
0				CL	TOPSOIL Stiff, moist, brown, Sandy CLAY, few rootlets				
2				SC	OTAY FORMATION (T₀) Medium dense, dry, whitish gray, Clayey, fine-grained SANDSTONE; weakly cemented				
4				SM	Dense, moist, light grayish brown, Silty, fine-to coarse-grained SANDSTONE; ("gritstone") moderately cemented, some gravel clasts within matrix				
6					-Becomes medium to coarse grained				
8	T14-1								
10					-Massive, well cemented				
					TRENCH TERMINATED AT 11 FEET				

Figure A-14,
Log of Trench T 14, Page 1 of 1

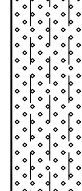
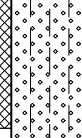
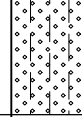
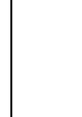
G1806-11-01.GPJ

SAMPLE SYMBOLS	 ... SAMPLING UNSUCCESSFUL	 ... STANDARD PENETRATION TEST	 ... DRIVE SAMPLE (UNDISTURBED)
	 ... DISTURBED OR BAG SAMPLE	 ... CHUNK SAMPLE	 ... WATER TABLE OR SEEPAGE

NOTE: THE LOG OF SUBSURFACE CONDITIONS SHOWN HEREON APPLIES ONLY AT THE SPECIFIC BORING OR TRENCH LOCATION AND AT THE DATE INDICATED. IT IS NOT WARRANTED TO BE REPRESENTATIVE OF SUBSURFACE CONDITIONS AT OTHER LOCATIONS AND TIMES.







DEPTH IN FEET	SAMPLE NO.	LITHOLOGY	GROUNDWATER	SOIL CLASS (USCS)	TRENCH T 15		PENETRATION RESISTANCE (BLOWS/FT.)	DRY DENSITY (P.C.F.)	MOISTURE CONTENT (%)
					ELEV. (MSL.) <u>538'</u>	DATE COMPLETED <u>02-04-2015</u>			
					EQUIPMENT <u>JD 555</u> BY: <u>M. ERTWINE</u>				
MATERIAL DESCRIPTION									
0	T15-1			CL	TOPSOIL Stiff, moist, brown, Sandy CLAY; residual soil				
2	T15-2				METAVOLCANIC ROCK (Mzu) Light grayish brown, decomposed moderately weak, METAVOLCANIC ROCK; ("saprolite"); excavates to silty, fine to medium sand -Massive -Difficult excavation, becomes black to dusky brown, strong metavolcanic rock; moderately fractured				
4									
6									
REFUSAL AT 7 FEET									

Figure A-15,
Log of Trench T 15, Page 1 of 1

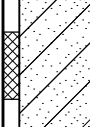
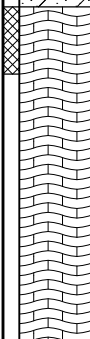
G1806-11-01.GPJ

SAMPLE SYMBOLS		... SAMPLING UNSUCCESSFUL		... STANDARD PENETRATION TEST		... DRIVE SAMPLE (UNDISTURBED)
		... DISTURBED OR BAG SAMPLE		... CHUNK SAMPLE		... WATER TABLE OR SEEPAGE

NOTE: THE LOG OF SUBSURFACE CONDITIONS SHOWN HEREON APPLIES ONLY AT THE SPECIFIC BORING OR TRENCH LOCATION AND AT THE DATE INDICATED. IT IS NOT WARRANTED TO BE REPRESENTATIVE OF SUBSURFACE CONDITIONS AT OTHER LOCATIONS AND TIMES.







DEPTH IN FEET	SAMPLE NO.	LITHOLOGY	GROUNDWATER	SOIL CLASS (USCS)	TRENCH T 16		PENETRATION RESISTANCE (BLOWS/FT.)	DRY DENSITY (P.C.F.)	MOISTURE CONTENT (%)		
					ELEV. (MSL.) <u>507'</u>	DATE COMPLETED <u>02-04-2015</u>					
					EQUIPMENT <u>JD 555</u>		BY: <u>M. ERTWINE</u>				
MATERIAL DESCRIPTION											
0				SC	TOPSOIL Loose, moist, reddish brown, Clayey SAND						
2					METAVOLCANIC ROCK (Mzu) Pale reddish brown, decomposed, moderately weak; METAVOLCANIC ROCK; -Excavates to clayey sand with gravel -Massive, becomes weak -Massive -Becomes moderately strong, difficult excavation						
4											
6											
8											
10											
12											
14					REFUSAL AT 14 FEET						

Figure A-16,
Log of Trench T 16, Page 1 of 1

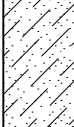
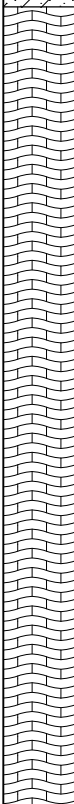
G1806-11-01.GPJ

SAMPLE SYMBOLS	 ... SAMPLING UNSUCCESSFUL	 ... STANDARD PENETRATION TEST	 ... DRIVE SAMPLE (UNDISTURBED)
	 ... DISTURBED OR BAG SAMPLE	 ... CHUNK SAMPLE	 ... WATER TABLE OR SEEPAGE

NOTE: THE LOG OF SUBSURFACE CONDITIONS SHOWN HEREON APPLIES ONLY AT THE SPECIFIC BORING OR TRENCH LOCATION AND AT THE DATE INDICATED. IT IS NOT WARRANTED TO BE REPRESENTATIVE OF SUBSURFACE CONDITIONS AT OTHER LOCATIONS AND TIMES.

DEPTH IN FEET	SAMPLE NO.	LITHOLOGY	GROUNDWATER	SOIL CLASS (USCS)	TRENCH T 17		PENETRATION RESISTANCE (BLOWS/FT.)	DRY DENSITY (P.C.F.)	MOISTURE CONTENT (%)
					ELEV. (MSL.) <u>411'</u>	DATE COMPLETED <u>02-04-2015</u>			
					EQUIPMENT <u>JD 555</u> BY: <u>M. ERTWINE</u>				
MATERIAL DESCRIPTION									
0				SC	TOPSOIL Loose, moist, brown, Clayey SAND				
2				SM	OTAY FORMATION (To) Medium dense, dry, whitish gray, Silty, fine-grained SANDSTONE; weakly cemented; abundant carbonates -Becomes fine- to coarse-grained; ("gritstone"); moderately cemented				
4	T17-1				-Becomes very dense, difficult excavation, well cemented				
6					TRENCH TERMINATED AT 6 FEET				

Figure A-17,
Log of Trench T 17, Page 1 of 1

G1806-11-01.GPJ

SAMPLE SYMBOLS	... SAMPLING UNSUCCESSFUL	... STANDARD PENETRATION TEST	... DRIVE SAMPLE (UNDISTURBED)
	... DISTURBED OR BAG SAMPLE	... CHUNK SAMPLE	... WATER TABLE OR SEEPAGE

NOTE: THE LOG OF SUBSURFACE CONDITIONS SHOWN HEREON APPLIES ONLY AT THE SPECIFIC BORING OR TRENCH LOCATION AND AT THE DATE INDICATED. IT IS NOT WARRANTED TO BE REPRESENTATIVE OF SUBSURFACE CONDITIONS AT OTHER LOCATIONS AND TIMES.







DEPTH IN FEET	SAMPLE NO.	LITHOLOGY	GROUNDWATER	SOIL CLASS (USCS)	TRENCH T 18		PENETRATION RESISTANCE (BLOWS/FT.)	DRY DENSITY (P.C.F.)	MOISTURE CONTENT (%)	
					ELEV. (MSL.) <u>449'</u>	DATE COMPLETED <u>02-04-2015</u>				
					EQUIPMENT <u>JD 555</u> BY: <u>M. ERTWINE</u>					
					MATERIAL DESCRIPTION					
0				SC	TOPSOIL Loose, moist, brown, Clayey SAND					
2				SM	OTAY FORMATION (To) Medium dense, moist, light gray, Silty, fine- to medium-grained SANDSTONE; abundant carbonates, weakly cemented					
4					-Becomes dense, whitish gray					
6					-Becomes very dense, well cemented					
8					-Massive					
					TRENCH TERMINATED AT 8 FEET					

Figure A-18,
Log of Trench T 18, Page 1 of 1

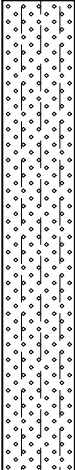
G1806-11-01.GPJ

SAMPLE SYMBOLS	 ... SAMPLING UNSUCCESSFUL	 ... STANDARD PENETRATION TEST	 ... DRIVE SAMPLE (UNDISTURBED)
	 ... DISTURBED OR BAG SAMPLE	 ... CHUNK SAMPLE	 ... WATER TABLE OR SEEPAGE

NOTE: THE LOG OF SUBSURFACE CONDITIONS SHOWN HEREON APPLIES ONLY AT THE SPECIFIC BORING OR TRENCH LOCATION AND AT THE DATE INDICATED. IT IS NOT WARRANTED TO BE REPRESENTATIVE OF SUBSURFACE CONDITIONS AT OTHER LOCATIONS AND TIMES.







DEPTH IN FEET	SAMPLE NO.	LITHOLOGY	GROUNDWATER	SOIL CLASS (USCS)	TRENCH T 19		PENETRATION RESISTANCE (BLOWS/FT.)	DRY DENSITY (P.C.F.)	MOISTURE CONTENT (%)	
					ELEV. (MSL.) <u>427'</u>	DATE COMPLETED <u>02-04-2015</u>				
					EQUIPMENT <u>JD 555</u>		BY: <u>M. ERTWINE</u>			
MATERIAL DESCRIPTION										
0				CL	TOPSOIL Stiff, mist, brown, Sandy CLAY					
2				SM	OTAY FORMATION (To) Medium dense, dry, brown, Silty, fine-grained SANDSTONE; weakly cemented -Becomes dense, medium to coarse grained -Becomes moist, gray, fine- to coarse-grained; ("gritstone") -Becomes very dense, difficult excavation, trace gravel clasts					
4										
6										
8					TRENCH TERMINATED AT 8 FEET					

Figure A-19,
Log of Trench T 19, Page 1 of 1

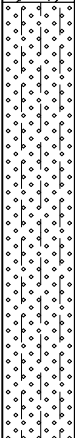
G1806-11-01.GPJ

SAMPLE SYMBOLS	 ... SAMPLING UNSUCCESSFUL	 ... STANDARD PENETRATION TEST	 ... DRIVE SAMPLE (UNDISTURBED)
	 ... DISTURBED OR BAG SAMPLE	 ... CHUNK SAMPLE	 ... WATER TABLE OR SEEPAGE

NOTE: THE LOG OF SUBSURFACE CONDITIONS SHOWN HEREON APPLIES ONLY AT THE SPECIFIC BORING OR TRENCH LOCATION AND AT THE DATE INDICATED. IT IS NOT WARRANTED TO BE REPRESENTATIVE OF SUBSURFACE CONDITIONS AT OTHER LOCATIONS AND TIMES.







DEPTH IN FEET	SAMPLE NO.	LITHOLOGY	GROUNDWATER	SOIL CLASS (USCS)	TRENCH T 20		PENETRATION RESISTANCE (BLOWS/FT.)	DRY DENSITY (P.C.F.)	MOISTURE CONTENT (%)
					ELEV. (MSL.) <u>426'</u>	DATE COMPLETED <u>02-04-2015</u>			
					EQUIPMENT <u>JD 555</u> BY: <u>M. ERTWINE</u>				
					MATERIAL DESCRIPTION				
0	T20-1			CH	TOPSOIL Stiff, reddish brown, Fat CLAY; residual soil				
2	T20-2				METAVOLCANIC ROCK (Mzu) Moderately weathered, grayish brown, strong METAVOLCANIC ROCK; slightly fractured				
4					REFUSAL AT 4 FEET				

Figure A-20,
Log of Trench T 20, Page 1 of 1

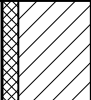
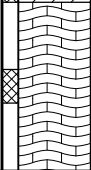
G1806-11-01.GPJ

SAMPLE SYMBOLS	 ... SAMPLING UNSUCCESSFUL	 ... STANDARD PENETRATION TEST	 ... DRIVE SAMPLE (UNDISTURBED)
	 ... DISTURBED OR BAG SAMPLE	 ... CHUNK SAMPLE	 ... WATER TABLE OR SEEPAGE

NOTE: THE LOG OF SUBSURFACE CONDITIONS SHOWN HEREON APPLIES ONLY AT THE SPECIFIC BORING OR TRENCH LOCATION AND AT THE DATE INDICATED. IT IS NOT WARRANTED TO BE REPRESENTATIVE OF SUBSURFACE CONDITIONS AT OTHER LOCATIONS AND TIMES.

APPENDIX

B

APPENDIX B

SEISMIC REFRACTION SURVEY REPORT

**PREPARED BY SOUTHWEST GEOPHYSICS, INC.
DATED MARCH 11, 2015 (PROJECT NO. 115075)**

FOR

**OTAY RANCH VILLAGE 4
CHULA VISTA, CALIFORNIA**

PROJECT NO. G1806-11-01

**SEISMIC REFRACTION SURVEY
OTAY RANCH VILLAGE 4
CHULA VISTA, CALIFORNIA**

PREPARED FOR:

Geocon, Inc.
6960 Flanders Drive
San Diego, CA 92121

PREPARED BY:

Southwest Geophysics, Inc.
8057 Raytheon Road, Suite 9
San Diego, CA 92111

March 11, 2015
Project No. 115075

March 11, 2015
Project No. 115075

Mr. Michael Ertwine
Geocon, Inc.
6960 Flanders Drive
San Diego, CA 92121

Subject: Seismic Refraction Survey
Otay Ranch Village 4
Chula Vista, California

Dear Mr. Ertwine:

In accordance with your authorization, we have performed a seismic refraction survey pertaining to the Otay Ranch Village 4 project located in Chula Vista, California. Specifically, our survey consisted of performing three seismic refraction traverses at the project site. The purpose of our study was to develop subsurface velocity profiles of the areas surveyed, and to assess the apparent rippability of the subsurface materials. This data report presents our survey methodology, equipment used, analysis, and results.

We appreciate the opportunity to be of service on this project. Should you have any questions related to this report, please contact the undersigned at your convenience.

Sincerely,

SOUTHWEST GEOPHYSICS, INC.

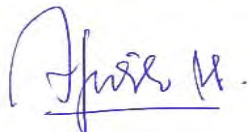

Afrildo Iko Syahrial
Project Geologist/Geophysicist



Patrick F. Lehrmann, P.G., P.Gp.
Principal Geologist/Geophysicist

AIS/PFL/HV/hv

Distribution: (1) Addressee (electronic)



TABLE OF CONTENTS

	Page
1. INTRODUCTION	1
2. SCOPE OF SERVICES	1
3. SITE AND PROJECT DESCRIPTION	1
4. SURVEY METHODOLOGY	1
5. ANALYSIS.....	3
6. RESULTS, CONCLUSIONS AND RECOMMENDATIONS.....	3
7. LIMITATIONS.....	4
8. SELECTED REFERENCES	5

Table

Table 1 – Rippability Classification	3
--	---

Figures

Figure 1	– Site Location Map
Figure 2	– Line Location Map
Figure 3	– Site Photographs
Figure 4a	– Seismic Profile, SL-1
Figure 4b	– Seismic Profile, SL-2
Figure 4c	– Seismic Profile, SL-3

1. INTRODUCTION

In accordance with your authorization, we have performed a seismic refraction survey pertaining to the Otay Ranch Village 4 project located in Chula Vista, California (Figure 1). Specifically, our survey consisted of performing three seismic P-wave refraction traverses at the project site. The purpose of our study was to develop subsurface velocity profiles of the areas surveyed, and to assess the apparent rippability of the subsurface materials. This data report presents our survey methodology, equipment used, analysis, and results.

2. SCOPE OF SERVICES

Our scope of services included:

- Performance of three seismic P-wave refraction lines (SL-1 through SL-3) at the project site.
- Compilation and analysis of the data collected.
- Preparation of this data report presenting our results and conclusions.

3. SITE AND PROJECT DESCRIPTION

The project site is generally located northeast of the corner of Main Street and Heritage Road in Chula Vista (Figure 1). The site consists of gentle to steep hills with several unmaintained dirt roads and trails crossing portions of the site. Vegetation in the area consists of heavy scrub brush and annual grass. Figures 2 and 3 depict the site conditions in the area of the seismic traverses.

Based on our discussions with you it is our understanding the project involves the construction of family residences and that site preparation will include cut and fill grading. Cuts up to 60 feet may be performed.

4. SURVEY METHODOLOGY

A seismic P-wave (compression wave) refraction survey was conducted at the site to evaluate the rippability characteristics of the subsurface materials and to develop subsurface velocity profiles of the areas surveyed. The seismic refraction method uses first-arrival times of refracted seismic waves to estimate the thicknesses and seismic velocities of subsurface layers. Seismic P-waves generated at the surface, using a hammer and plate, are refracted at boundaries separating materi-

als of contrasting velocities. These refracted seismic waves are then detected by a series of vertical component geophones and recorded with a 24-channel Geometrics Geode seismograph. The travel times of the seismic P-waves are used in conjunction with the shot-to-geophone distances to obtain thickness and velocity information on the subsurface materials.

Three seismic lines (SL-1 through SL-3) were conducted in the study area. The general line locations were delineated by your office as well as the desired exploration depths. Seismic line SL-1 was 240 feet long and lines SL-2 and SL-3 were 200 feet long. Shot points (signal generation locations) were conducted near the ends, midpoint, and intermediate points between the ends and the midpoint. In general, the effective depth of evaluation for a seismic refraction traverse is approximately one-third to one-fifth the length of the traverse.

The refraction method requires that subsurface velocities increase with depth. A layer having a velocity lower than that of the layer above will not generally be detectable by the seismic refraction method and, therefore, could lead to errors in the depth calculations of subsequent layers. In addition, lateral variations in velocity, such as those caused by core stones or intrusions can also result in the misinterpretation of the subsurface conditions.

The rippability values presented in Table 1 are based on our experience with similar materials and assume that a Caterpillar D-9 dozer ripping with a single shank is used. We emphasize that the cutoffs in this classification scheme are approximate and that rock characteristics, such as fracture spacing and orientation, play a significant role in determining rock rippability. These characteristics may also vary with location and depth. For trenching operations, the rippability values should be scaled downward. For example, velocities as low as 3,500 feet/second may indicate difficult ripping during trenching operations. In addition, the presence of boulders, which can be troublesome in a narrow trench, should be anticipated.

Table 1 – Rippability Classification	
Seismic P-wave Velocity	Rippability
0 to 2,000 feet/second	Easy
2,000 to 4,000 feet/second	Moderate
4,000 to 5,500 feet/second	Difficult, Possible Blasting
5,500 to 7,000 feet/second	Very Difficult, Probable Blasting
Greater than 7,000 feet/second	Blasting Generally Required

It should be noted that the rippability cutoffs presented in Table 1 are slightly more conservative than those published in the Caterpillar Performance Handbook (Caterpillar, 2011). Accordingly, the above classification scheme should be used with discretion, and contractors should not be relieved of making their own independent evaluation of the rippability of the on-site materials prior to submitting their bids.

5. ANALYSIS

As previously indicated, three seismic traverses were conducted as part of our study. The collected data were processed using SIPwin (Rimrock Geophysics, 2003), a seismic interpretation program, and analyzed using SeisOpt Pro (Optim, 2008) which uses first arrival picks and elevation data to produce subsurface velocity models. SeisOpt Pro uses a nonlinear optimization technique called adaptive simulated annealing. The resulting velocity model provides a tomography image of the estimated geologic conditions. Both vertical and lateral velocity information is contained in the tomography model. Changes in layer velocity are revealed as gradients rather than discrete contacts, which typically are more representative of actual conditions.

6. RESULTS, CONCLUSIONS AND RECOMMENDATIONS

Figures 4a through 4c provide the velocity models calculated from SeisOpt Pro. Distinct vertical and lateral velocity variations are evident in the models. These inhomogeneities are likely related to the presence of remnant boulders, intrusions and differential weathering of the bedrock materials. It is also evident in the tomography models that the depth to bedrock is highly variable across the site.

Based on the refraction results, variability in the excavatability (including depth of rippability) of the subsurface materials should be expected across the project area. Furthermore, blasting may be required depending on the excavation depth, location, equipment used, and desired rate of production. In addition, oversized materials should be expected. A contractor with excavation experience in similar potentially difficult conditions should be consulted for expert advice on excavation methodology, equipment and production rate.

7. LIMITATIONS

The field evaluation and geophysical analyses presented in this report have been conducted in general accordance with current practice and the standard of care exercised by consultants performing similar tasks in the project area. No warranty, express or implied, is made regarding the conclusions, recommendations, and opinions presented in this report. There is no evaluation detailed enough to reveal every subsurface condition. Variations may exist and conditions not observed or described in this report may be present. Uncertainties relative to subsurface conditions can be reduced through additional subsurface exploration. Additional subsurface surveying will be performed upon request.

This document is intended to be used only in its entirety. No portion of the document, by itself, is designed to completely represent any aspect of the project described herein. Southwest Geophysics, Inc. should be contacted if the reader requires additional information or has questions regarding the content, interpretations presented, or completeness of this document. This report is intended exclusively for use by the client. Any use or reuse of the findings, conclusions, and/or recommendations of this report by parties other than the client is undertaken at said parties' sole risk.

8. SELECTED REFERENCES

Caterpillar, Inc., 2011, Caterpillar Performance Handbook, Edition 41, Caterpillar, Inc., Peoria, Illinois.

Mooney, H.M., 1976, Handbook of Engineering Geophysics, dated February.

Optim, Inc., 2008, SeisOpt Pro, V-5.0.

Rimrock Geophysics, 2003, Seismic Refraction Interpretation Program (SIPwin), V-2.76.

Telford, W.M., Geldart, L.P., Sheriff, R.E., and Keys, D.A., 1976, Applied Geophysics, Cambridge University Press.

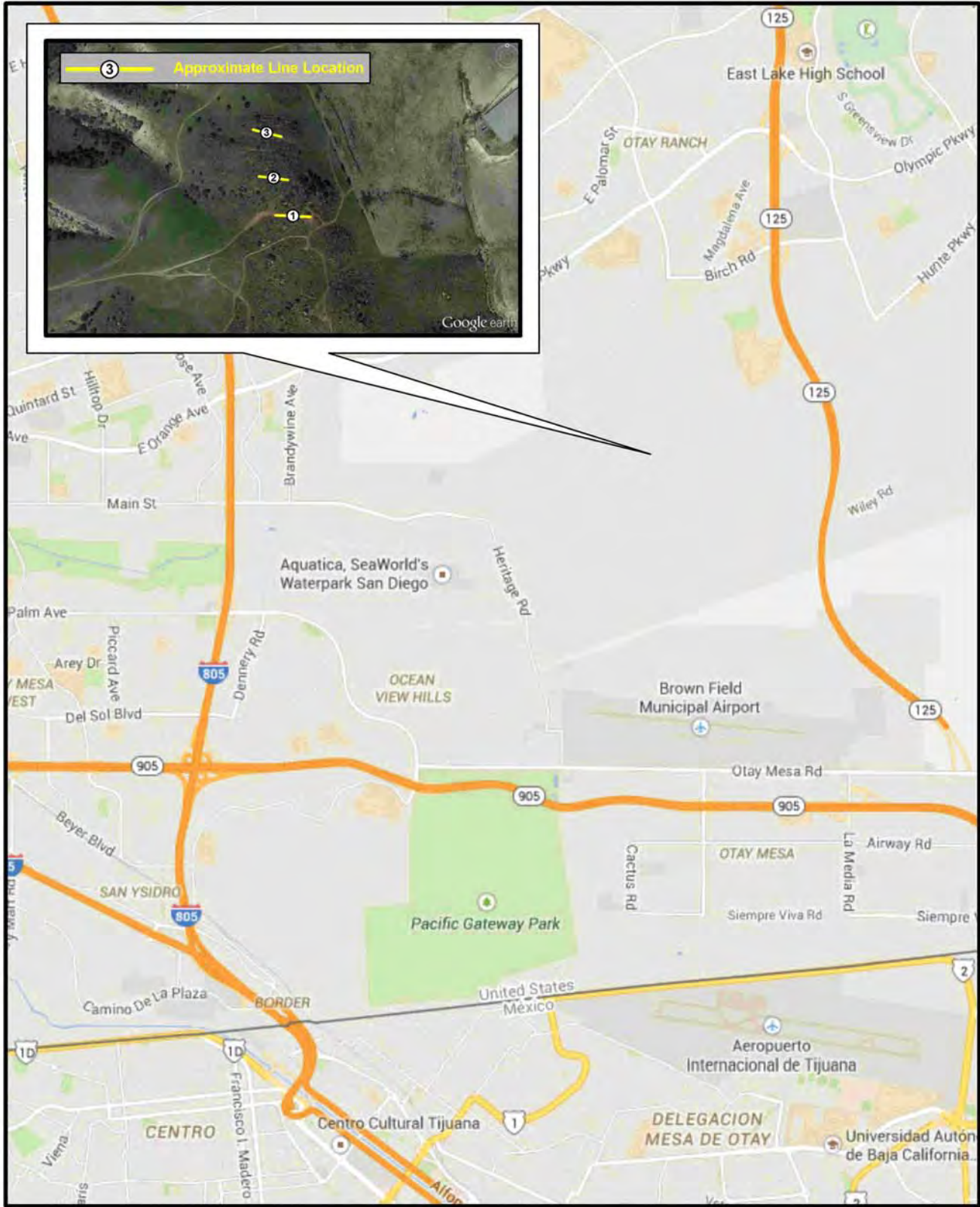

SITE LOCATION MAP



Otay Ranch Village 4
Chula Vista, California

Project No.: 115075

Date: 03/15



Figure 1



LEGEND

Seismic Line SL-3 200

LINE LOCATION MAP



Otay Ranch Village 4
Chula Vista, California

Project No.: 115075

Date: 03/15

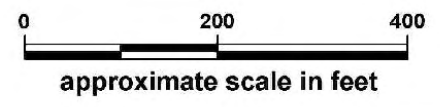
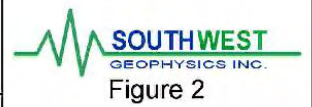



SITE PHOTOGRAPHS

Otay Ranch Village 4
Chula Vista, California

Project No.: 115075

Date: 03/15



Figure 3

TOMOGRAPHY MODEL

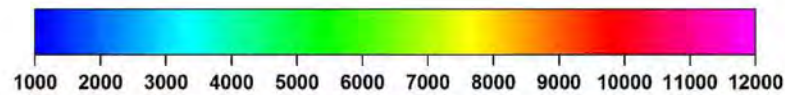
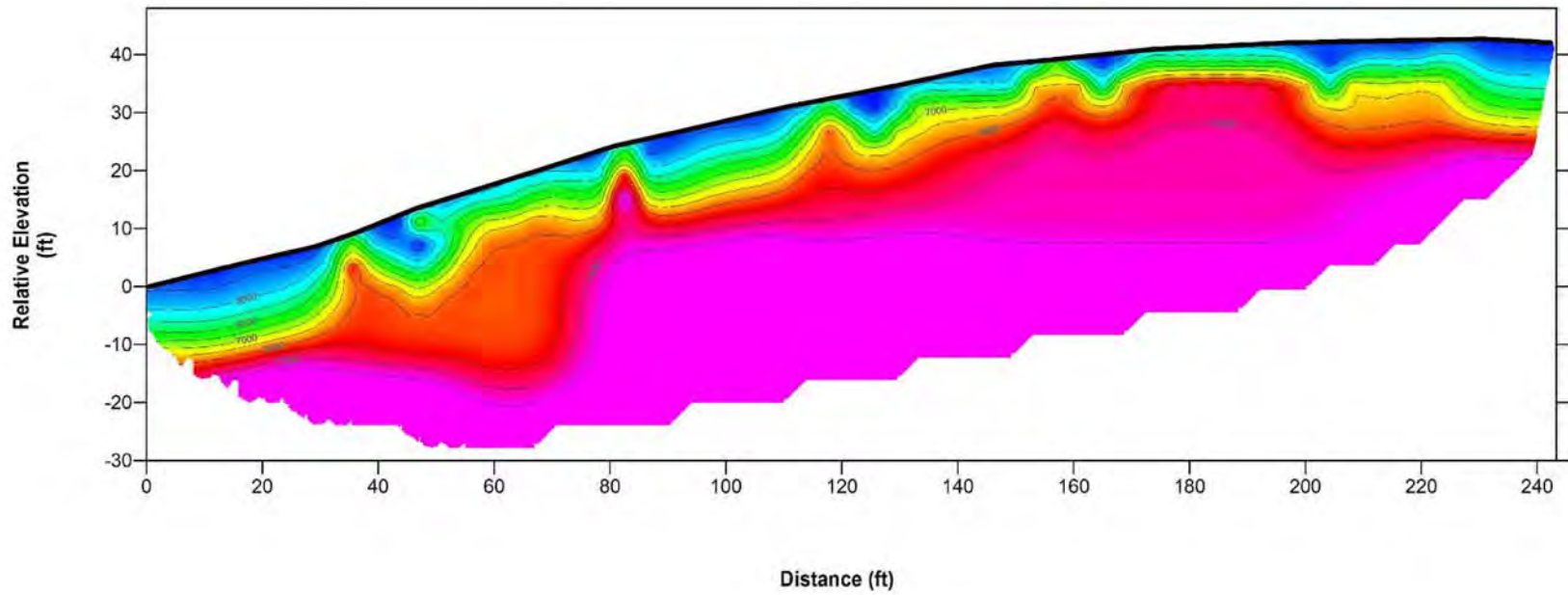

Velocity (ft/s)

**SEISMIC PROFILE
SL-1**

Otay Ranch Village 4
Chula Vista, California

Project No.: 115075

Date: 03/15



Figure 4a

Note: Contour Interval = 1,000 feet per second

TOMOGRAPHY MODEL

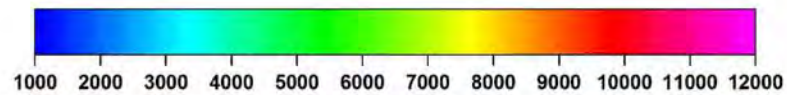
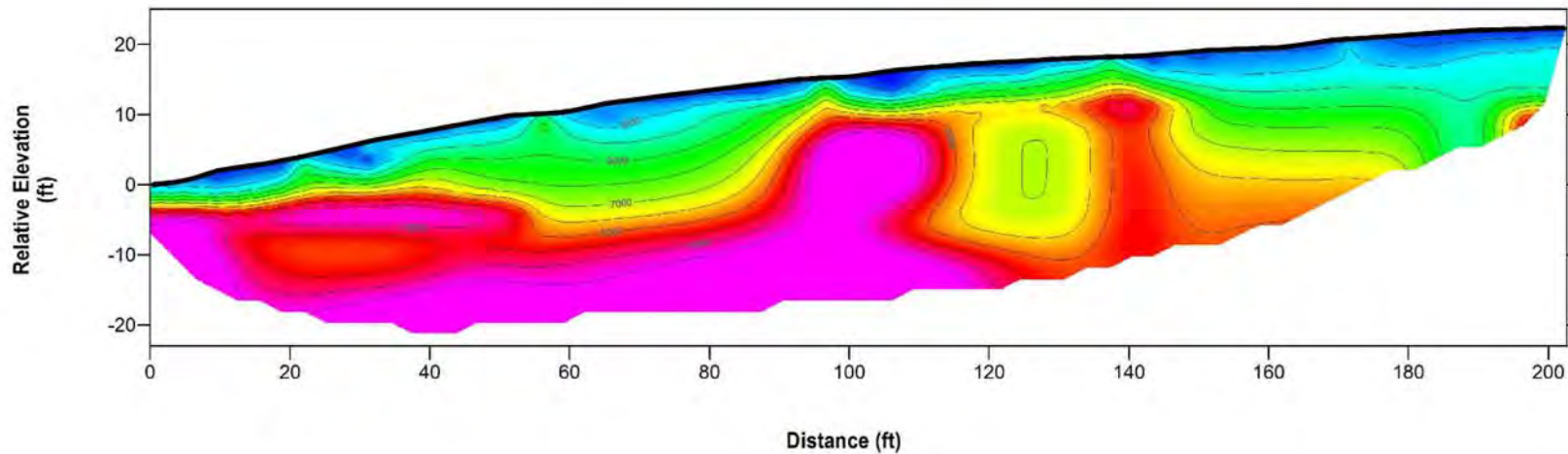

Velocity (ft/s)

**SEISMIC PROFILE
SL-2**

Otay Ranch Village 4
Chula Vista, California

Project No.: 115075

Date: 03/15



Figure 4b

Note: Contour Interval = 1,000 feet per second

TOMOGRAPHY MODEL

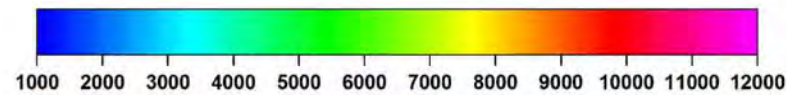
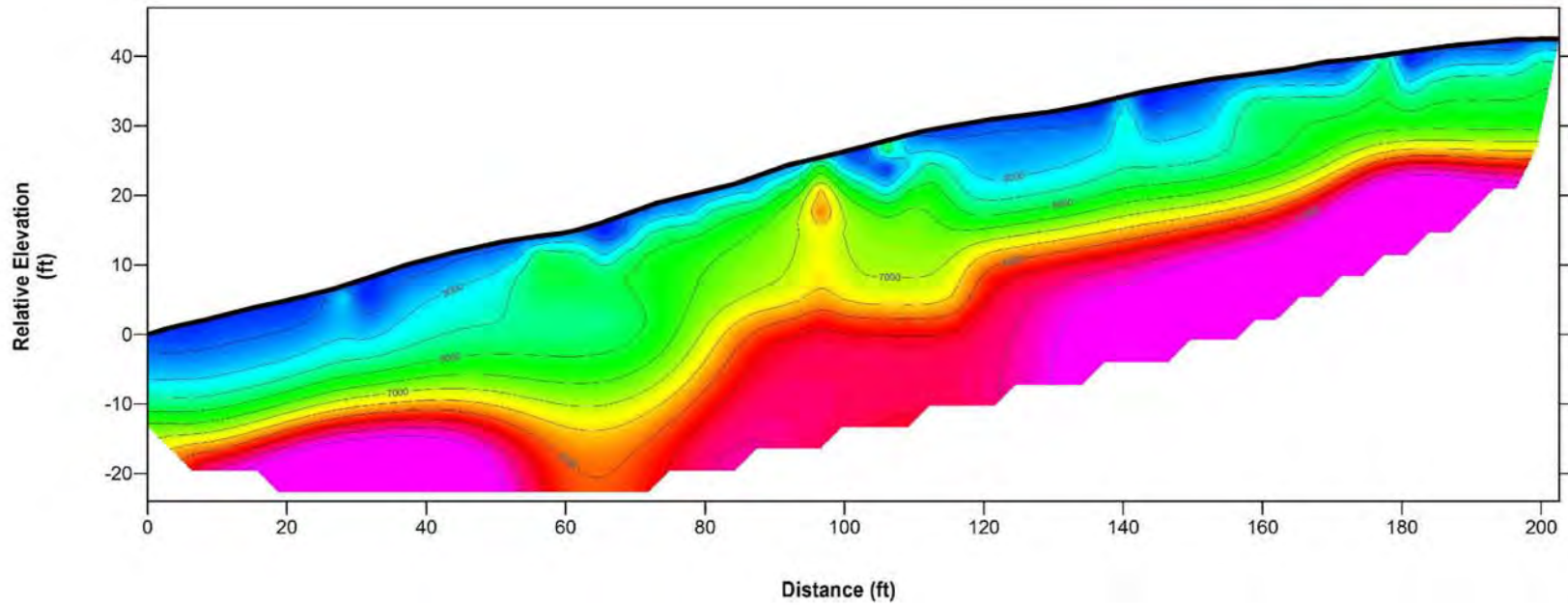

Velocity (ft/s)

**SEISMIC PROFILE
SL-3**

Otay Ranch Village 4
Chula Vista, California

Project No.: 115075

Date: 03/15



Figure 4c

Note: Contour Interval = 1,000 feet per second

APPENDIX

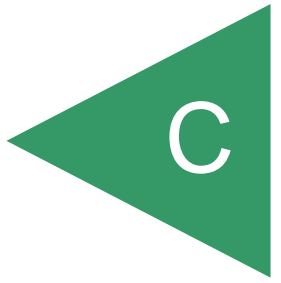

APPENDIX C

LABORATORY TESTING

We performed laboratory tests in accordance with generally accepted test methods of the American Society for Testing and Materials (ASTM) or other suggested procedures. Selected soil samples were analyzed for maximum dry density and optimum moisture content, direct shear strength, expansion potential, water-soluble sulfate, water-soluble chloride ion, and R-Value characteristics. The results of the laboratory tests are presented on Tables C-I through C-VI.

**TABLE C-I
SUMMARY OF LABORATORY MAXIMUM DRY DENSITY AND
OPTIMUM MOISTURE CONTENT TEST RESULTS
ASTM D 1557**

Sample No.	Description (Geologic Unit)	Maximum Dry Density (pcf)	Optimum Moisture Content (% dry wt.)
T4-1	Dark gray, Clayey SILT (To)	105.5	18.7
T6-1	Yellowish brown, Clayey SILT (To)	111.2	18.1

**TABLE C-II
SUMMARY OF LABORATORY DIRECT SHEAR TEST RESULTS
ASTM D 3080**

Sample No.	Dry Density (pcf)	Moisture Content (%)		Peak [Ultimate] Cohesion (psf)	Peak [Ultimate] Angle of Shear Resistance (degrees)
		Initial	After Test		
T4-1	95.5	18.1	29.2	360[200]	31[31]
T6-1	100.7	17.6	25.0	530[310]	28[28]

Samples remolded to a dry density of approximately 90 percent of the laboratory maximum dry density near optimum moisture content.

**TABLE C-III
SUMMARY OF LABORATORY EXPANSION INDEX TEST RESULTS
ASTM D 4829**

Sample No. (Geologic Unit)	Moisture Content (%)		Dry Density (pcf)	Expansion Index	Expansion Classification
	Before Test	After Test			
T3-1 (Qc)	19.0	37.7	84.4	74	Medium
T4-1 (To)	16.4	31.4	89.9	60	Medium
T5-2 (To)	20.1	41.3	81.0	95	High
T15-2 (To)	8.8	17.4	112.4	12	Very Low

**TABLE C-IV
SUMMARY OF LABORATORY WATER-SOLUBLE SULFATE TEST RESULTS
CALIFORNIA TEST NO. 417**

Sample No.	Water-Soluble Sulfate (%)	Sulfate Severity	Sulfate Class
T4-1	0.048	Not Applicable	S0
T5-2	0.049	Not Applicable	S0
T15-2	0.005	Not Applicable	S0

**TABLE C-V
SUMMARY OF LABORATORY WATER-SOLUBLE CHLORIDE ION CONTENT TEST RESULTS
AASHTO TEST NO. T 291**

Sample No.	Chloride Ion Content (%)	Chloride Ion Content (ppm)
T4-1	0.201	2,014
T5-2	0.179	1,789
T15-2	0.034	341

**TABLE C-VI
SUMMARY OF LABORATORY RESISTANCE VALUE (R-VALUE) TEST RESULTS
ASTM D 2844**

Sample No.	R-Value
T3-1	26
T13-1	64

APPENDIX

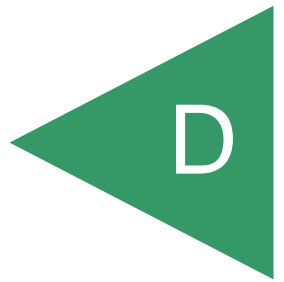

APPENDIX D

SLOPE STABILITY ANALYSIS

We performed slope stability analyses using a two-dimensional computer software *GeoStudio2007* developed by Geo-Slope International Ltd. We analyzed the critical modes of potential slip surfaces including rotational-mode and block-mode based on Spencer's method. The soil parameters used, case conditions, and the calculated factors of safety were presented herein. Plots of analyses' results, including the soil stratigraphy, potential failure surfaces, and calculated Factors of Safety, are included in this appendix.

Shear strength characters of the existing geologic units were estimated based on laboratory direct shear tests on samples obtained during our field investigation in accordance with ASTM D 3080 (see Appendix C), and based on empirical data obtained from the referenced geotechnical literature. The soil parameters used for the stability analyses are presented on Table D-I.

**TABLE D-I
SUMMARY OF SOIL PROPERTIES USED FOR SLOPE STABILITY ANALYSES**

Geologic Unit/Material	Density (pcf)	Cohesion (psf)	Friction Angle (degrees)
Compacted Fill (Qcf)	130	300	28
Alluvium (Qal)	130	200	23
Landslide Debris (Qls)	130	200	23
Otay Formation (To) - Sandstone	130	325	33
Otay Formation (Tob) – Bentonite Claystone	130	50	10
Metavolcanic Rock (Mzu)	130	0	35

We selected Cross Sections A-A', B-B', C-C', D-D', and E-E' to perform the slope stability analyses. Table D-II provides a summary of cases analyzed and calculated Factors of Safety. A minimum Factor of Safety of 1.5 under static conditions is currently required by the City of Chula Vista for slope stability. Results of slope stability analyses are plotted on Figures D-1 through D-21. As discussed herein, we encountered discontinuous claystone layers in several of the exploratory borings and trenches within the Otay Formation (To). The claystone possesses relatively low shear strengths and may be prone to slope instability if exposed in cut slopes. These claystone layers were found in cross sections A-A' through E-E'. Figure D-22 presents the surficial slope stability calculations.

**TABLE D-II
SUMMARY OF SLOPE STABILITY ANALYSES**

Figure Number	Cross Section	Condition of Slope Stability Analyses	Calculated Factor of Safety
1	A-A' Case 2	Block-mode analysis, along bentonite, lower layer	1.26
2	A-A' Case 2a	Block-mode analysis, along bentonite, lower layer, location where Factor of Safety equals 1.5	1.50
3	A-A' Case 3a	Block-mode analysis, along bentonite, middle layer	0.60
4	A-A' Case 3	Block-mode analysis, along bentonite, middle layer, location where Factor of Safety equals 1.5	1.50
5	A-A' Case 4	Block-mode analysis, along bentonite, upper layer	2.16
6	A-A' Case 1	Rotational-mode analysis	1.41
7	A-A' Case 1a	Rotational-mode analysis, location where Factor of Safety equals 1.5	1.52
8	B-B' Case 1	Block-mode analysis, along bentonite, lower layer	1.92
9	B-B' Case 2	Block-mode analysis, along bentonite, middle layer	1.89
10	B-B' Case 3	Block-mode analysis, along bentonite, upper layer	1.94
11	B-B' Case 4	Rotational-mode analysis	2.80
12	B-B' Case 1b	Block-mode analysis, along bentonite, lower layer, with pore-water pressure	1.53
13	B-B' Case 2b	Block-mode analysis, along bentonite, middle layer, with pore-water pressure	1.53
14	B-B' Case 3b	Block-mode analysis, along bentonite, upper layer, with pore-water pressure	1.73
15	B-B' Case 4b	Rotational-mode analysis, with pore-water pressure	2.45
16	C-C' Case 2	Block-mode analysis, along bentonite	2.28
17	C-C' Case 1	Rotational-mode analysis	1.63
18	D-D' Case 2	Block-mode analysis, along bentonite	1.55
19	D-D' Case 1	Rotational-mode analysis	1.53
20	E-E' Case 2	Block-mode analysis, along bentonite	1.54
21	D-D' Case 1	Rotational-mode analysis	1.51
22	--	Surficial Slope Stability Analysis	2.5

Otay Ranch Village 4
 Project No. G1806-11-01
 Section A-A'
 Name: A-A' Case 2.gsz
 Date: 3/9/2015 Time: 10:13:37 AM

Material Properties:

Name: To Unit Weight: 130 pcf Cohesion: 325 psf Phi: 33 °
 Name: Tob Unit Weight: 130 pcf Cohesion: 50 psf Phi: 10 °
 Name: Qal Unit Weight: 130 pcf Cohesion: 200 psf Phi: 23 °
 Name: Qudf Unit Weight: 120 pcf Cohesion: 200 psf Phi: 25 °

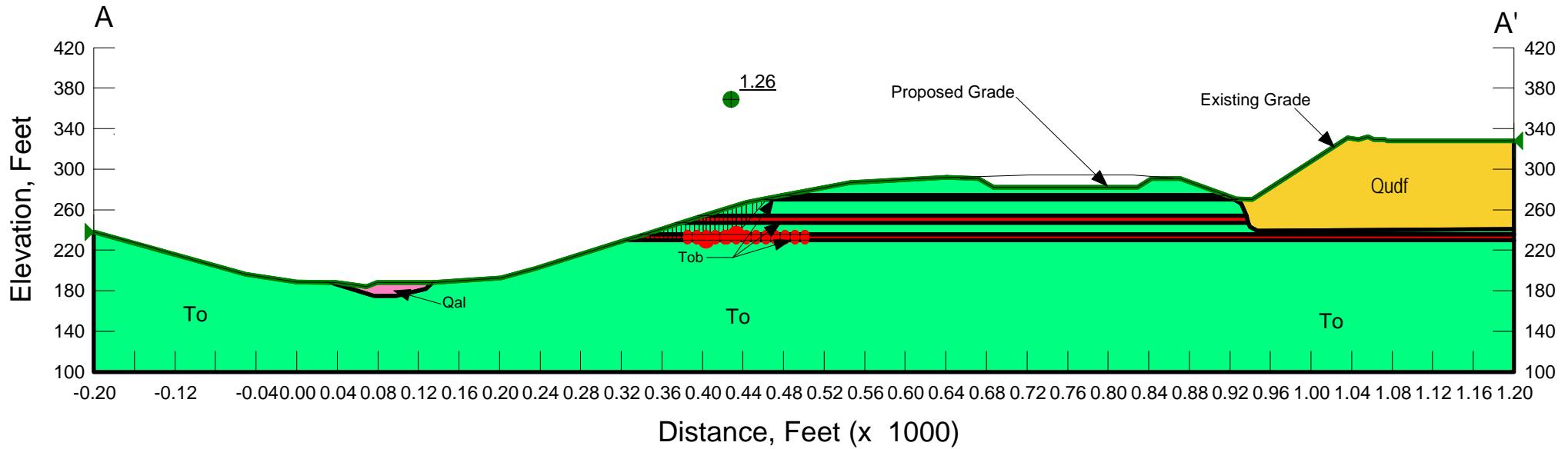

Figure D-1

Otay Ranch Village 4
 Project No. G1806-11-01
 Section A-A'
 Name: A-A' Case 2a.gsz
 Date: 3/9/2015 Time: 10:18:05 AM

Material Properties:

Name: To Unit Weight: 130 pcf Cohesion: 325 psf Phi: 33 °
 Name: Tob Unit Weight: 130 pcf Cohesion: 50 psf Phi: 10 °
 Name: Qal Unit Weight: 130 pcf Cohesion: 200 psf Phi: 23 °
 Name: Qudf Unit Weight: 120 pcf Cohesion: 200 psf Phi: 25 °

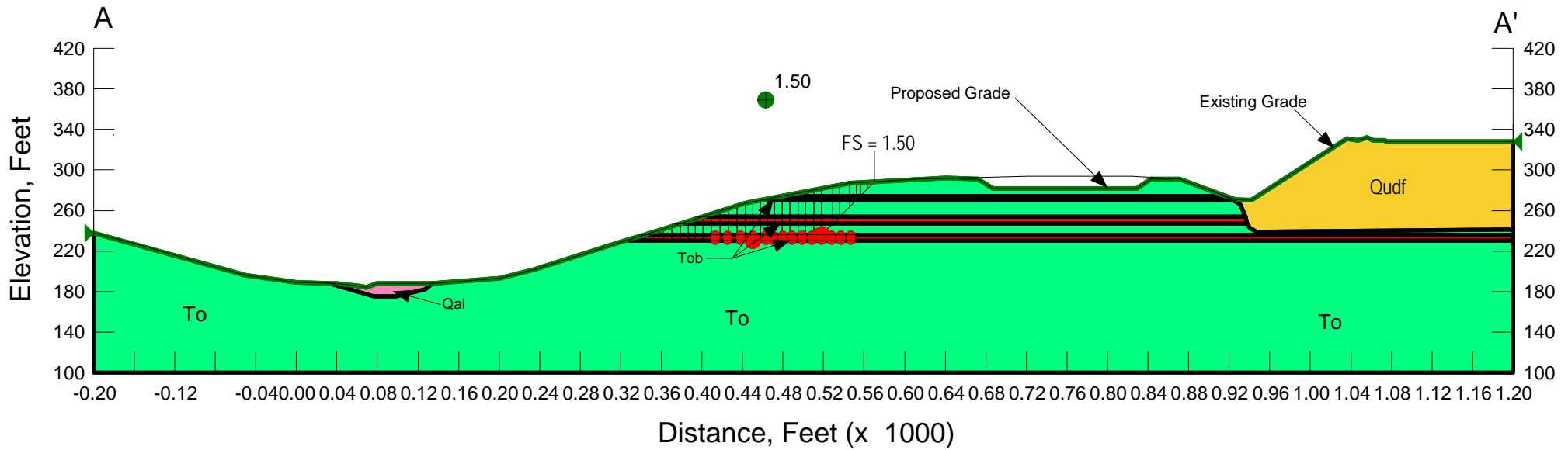

Figure D-2

Otay Ranch Village 4
 Project No. G1806-11-01
 Section A-A'
 Name: A-A' Case 3a.gsz
 Date: 3/9/2015 Time: 3:58:35 PM

Material Properties:

Name: To Unit Weight: 130 pcf Cohesion: 325 psf Phi: 33 °
 Name: Tob Unit Weight: 130 pcf Cohesion: 50 psf Phi: 10 °
 Name: Qal Unit Weight: 130 pcf Cohesion: 300 psf Phi: 28 °
 Name: Qudf Unit Weight: 120 pcf Cohesion: 200 psf Phi: 25 °

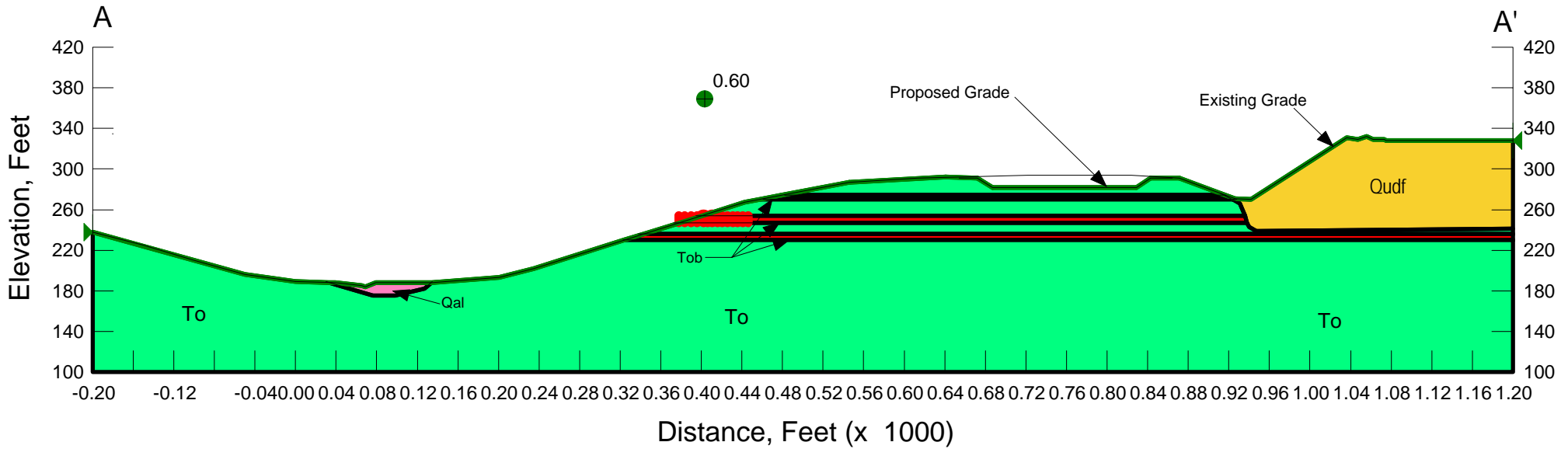

Figure D-3

Otay Ranch Village 4
 Project No. G1806-11-01
 Section A-A'
 Name: A-A' Case 3.gsz
 Date: 3/6/2015 Time: 10:27:24 AM

Material Properties:

Name: To Unit Weight: 130 pcf Cohesion: 325 psf Phi: 33 °
 Name: Tob Unit Weight: 130 pcf Cohesion: 50 psf Phi: 10 °
 Name: Qal Unit Weight: 130 pcf Cohesion: 300 psf Phi: 28 °
 Name: Qudf Unit Weight: 120 pcf Cohesion: 200 psf Phi: 25 °

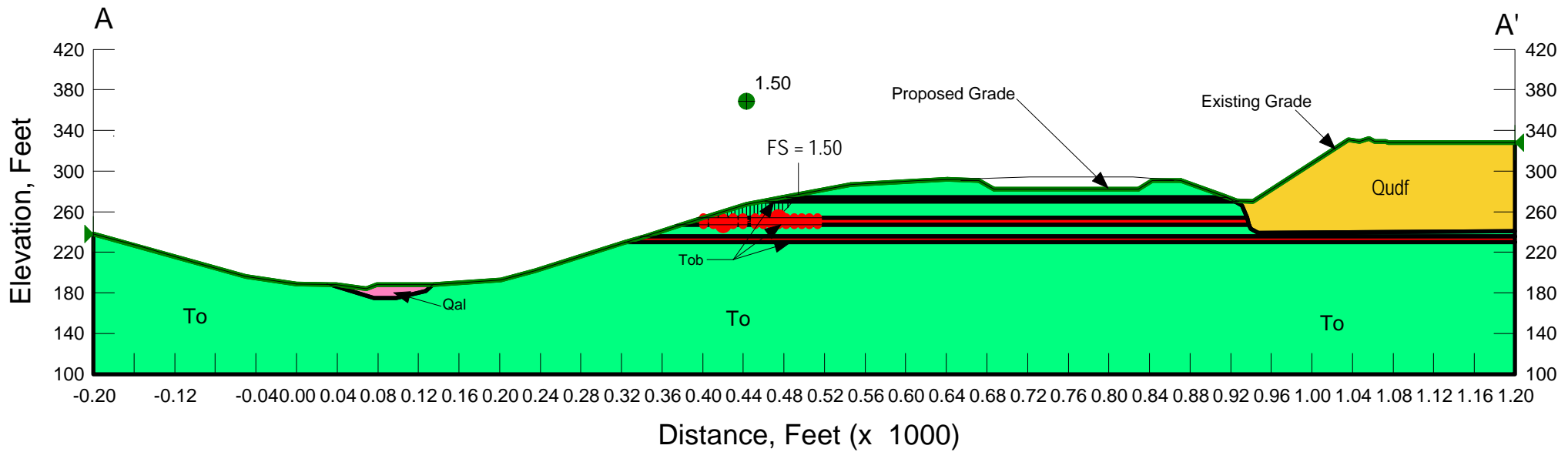

Figure D-4

Otay Ranch Village 4
 Project No. G1806-11-01
 Section A-A'
 Name: A-A' Case 4.gsz
 Date: 3/6/2015 Time: 10:36:30 AM

Material Properties:

Name: To Unit Weight: 130 pcf Cohesion: 325 psf Phi: 33 °
 Name: Tob Unit Weight: 130 pcf Cohesion: 50 psf Phi: 10 °
 Name: Qal Unit Weight: 130 pcf Cohesion: 300 psf Phi: 28 °
 Name: Qudf Unit Weight: 120 pcf Cohesion: 200 psf Phi: 25 °

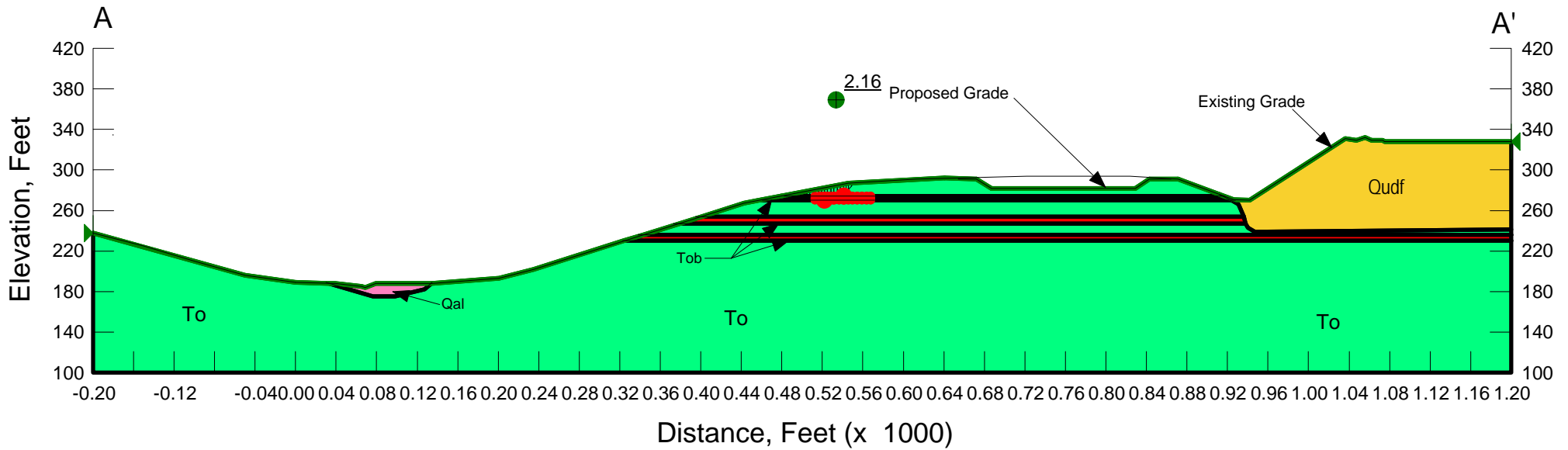

Figure D-5

Otay Ranch Village 4
 Project No. G1806-11-01
 Section A-A'
 Name: A-A' Case 1.gsz
 Date: 3/9/2015 Time: 10:09:48 AM

Material Properties:

Name: To Unit Weight: 130 pcf Cohesion: 325 psf Phi: 33 °
 Name: Tob Unit Weight: 130 pcf Cohesion: 50 psf Phi: 10 °
 Name: Qal Unit Weight: 130 pcf Cohesion: 200 psf Phi: 23 °
 Name: Qudf Unit Weight: 120 pcf Cohesion: 200 psf Phi: 25 °

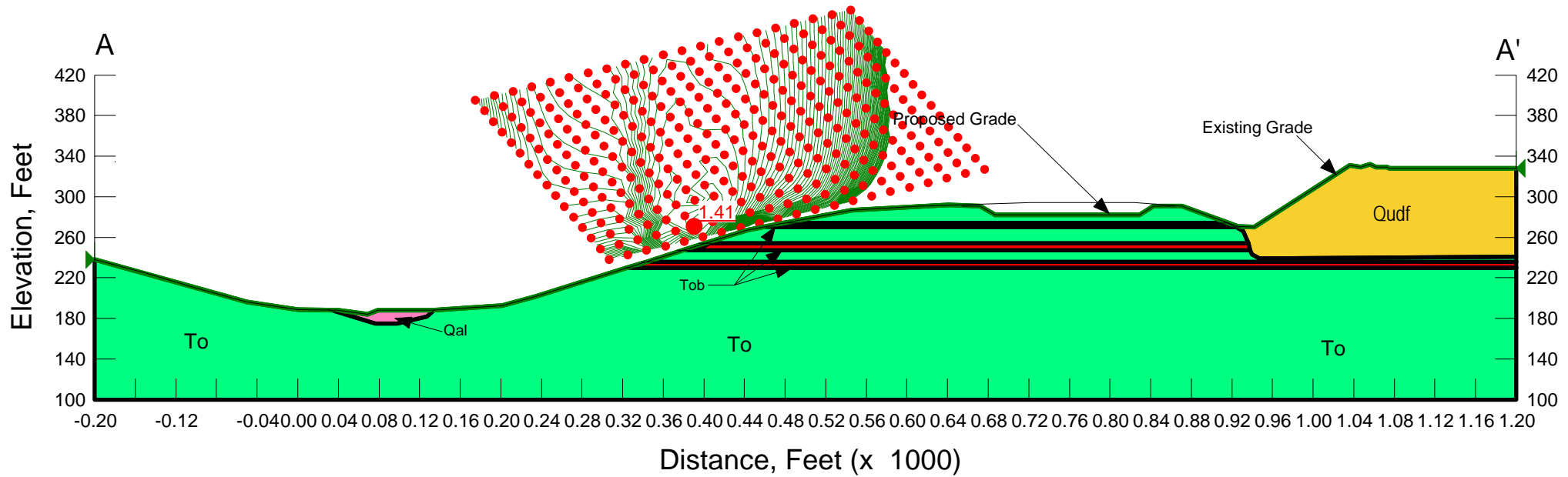

Figure D-6

Otay Ranch Village 4
 Project No. G1806-11-01
 Section A-A'
 Name: A-A' Case 1a.gsz
 Date: 3/9/2015 Time: 10:09:48 AM

Material Properties:

Name: To Unit Weight: 130 pcf Cohesion: 325 psf Phi: 33 °
 Name: Tob Unit Weight: 130 pcf Cohesion: 50 psf Phi: 10 °
 Name: Qal Unit Weight: 130 pcf Cohesion: 200 psf Phi: 23 °
 Name: Qudf Unit Weight: 120 pcf Cohesion: 200 psf Phi: 25 °

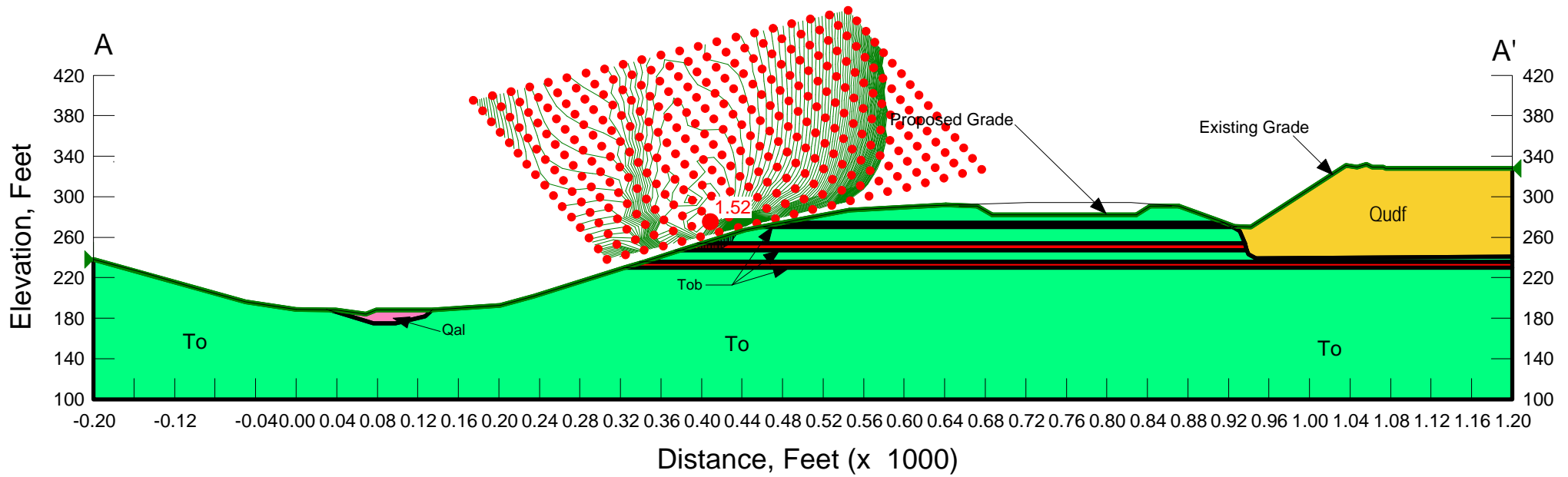

Figure D-7

Otay Ranch Village 4
 Project No. G1806-11-01
 Section B-B'
 Name: B-B' Case 1.gsz
 Date: 3/9/2015 Time: 10:00:13 AM

Material Properties:

Name: Qcf	Unit Weight: 130 pcf	Cohesion: 300 psf	Phi: 28 °
Name: To	Unit Weight: 130 pcf	Cohesion: 325 psf	Phi: 33 °
Name: Tob	Unit Weight: 130 pcf	Cohesion: 50 psf	Phi: 10 °
Name: Qal	Unit Weight: 130 pcf	Cohesion: 200 psf	Phi: 23 °
Name: Qls	Unit Weight: 130 pcf	Cohesion: 200 psf	Phi: 23 °
Name: Mzu	Unit Weight: 130 pcf	Cohesion: 0 psf	Phi: 35 °

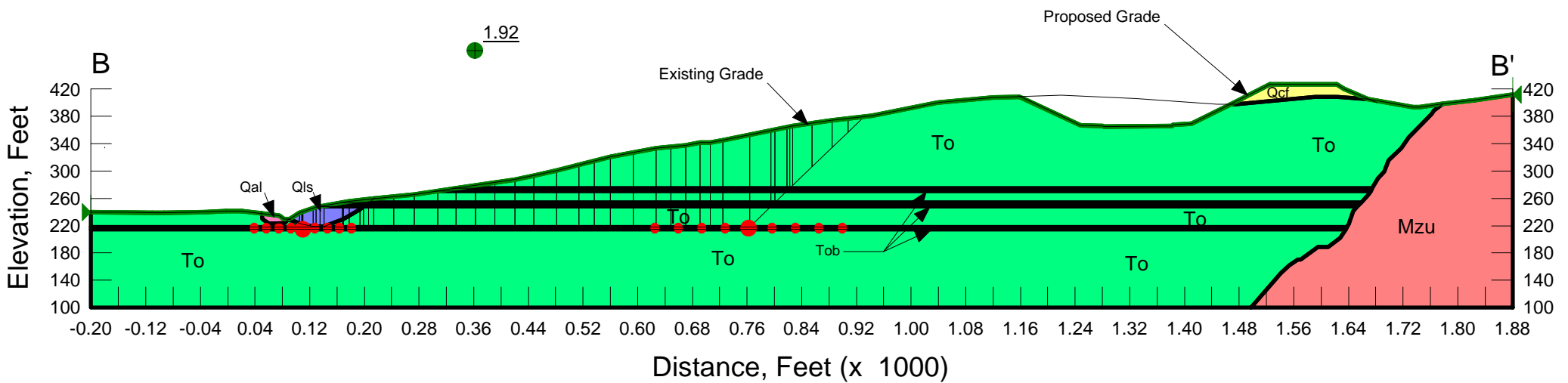

Figure D-8

Otay Ranch Village 4
 Project No. G1806-11-01
 Section B-B'
 Name: B-B' Case 2.gsz
 Date: 3/9/2015 Time: 9:47:45 AM

Material Properties:

Name: Qcf	Unit Weight: 130 pcf	Cohesion: 300 psf	Phi: 28 °
Name: To	Unit Weight: 130 pcf	Cohesion: 325 psf	Phi: 33 °
Name: Tob	Unit Weight: 130 pcf	Cohesion: 50 psf	Phi: 10 °
Name: Qal	Unit Weight: 130 pcf	Cohesion: 200 psf	Phi: 23 °
Name: Qls	Unit Weight: 130 pcf	Cohesion: 200 psf	Phi: 23 °
Name: Mzu	Unit Weight: 130 pcf	Cohesion: 0 psf	Phi: 35 °

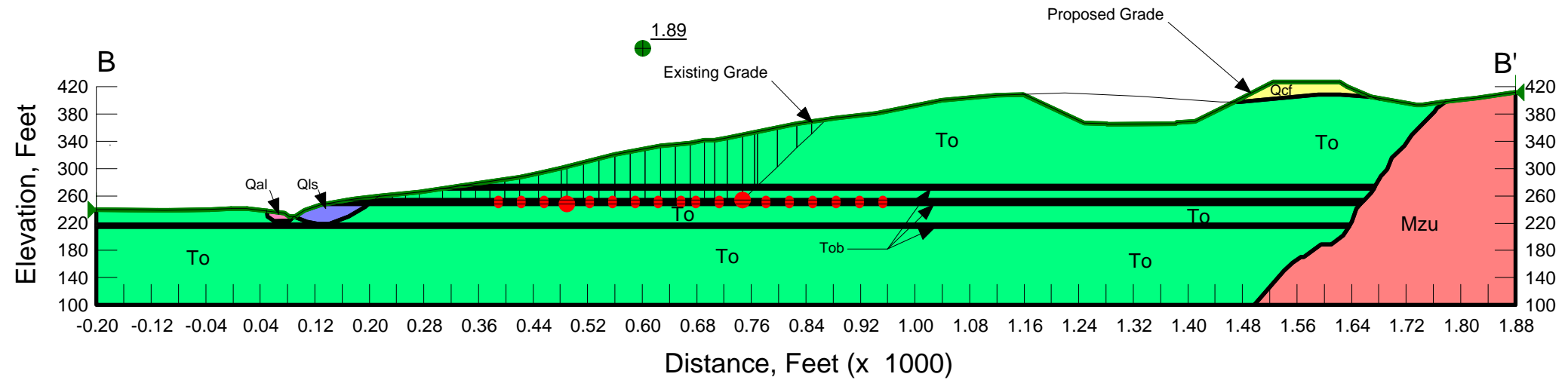

Figure D-9

Otay Ranch Village 4
 Project No. G1806-11-01
 Section B-B'
 Name: B-B' Case 3.gsz
 Date: 3/9/2015 Time: 3:42:39 PM

Material Properties:

Name: Qcf	Unit Weight: 130 pcf	Cohesion: 300 psf	Phi: 28 °
Name: To	Unit Weight: 130 pcf	Cohesion: 325 psf	Phi: 33 °
Name: Tob	Unit Weight: 130 pcf	Cohesion: 50 psf	Phi: 10 °
Name: Qal	Unit Weight: 130 pcf	Cohesion: 200 psf	Phi: 23 °
Name: Qls	Unit Weight: 130 pcf	Cohesion: 200 psf	Phi: 23 °
Name: Mzu	Unit Weight: 130 pcf	Cohesion: 0 psf	Phi: 35 °

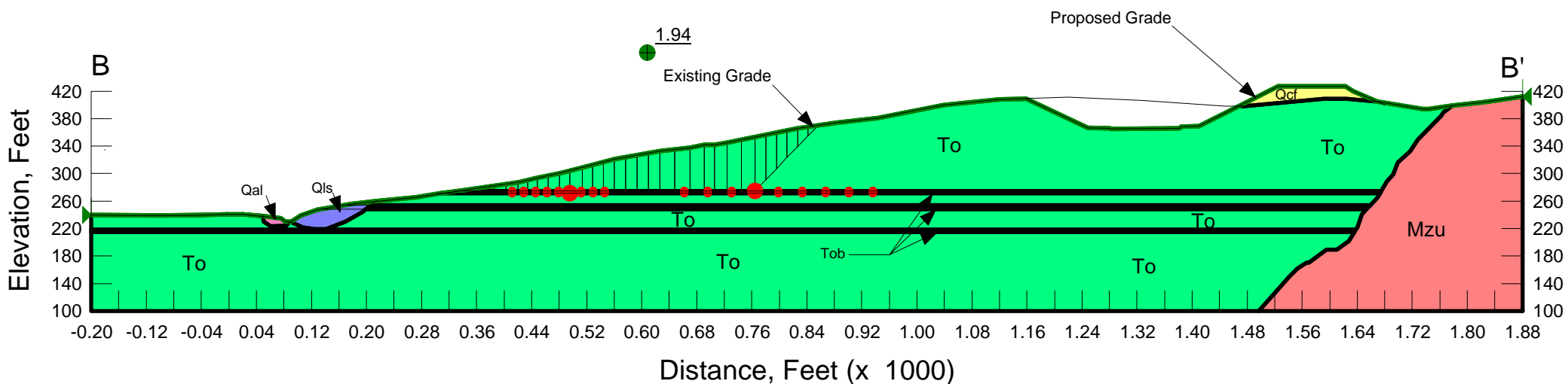

Figure D-10

Otay Ranch Village 4
 Project No. G1806-11-01
 Section B-B'
 Name: B-B' Case 4.gsz
 Date: 3/9/2015 Time: 3:44:15 PM

Material Properties:

Name: Qcf	Unit Weight: 130 pcf	Cohesion: 300 psf	Phi: 28 °
Name: To	Unit Weight: 130 pcf	Cohesion: 325 psf	Phi: 33 °
Name: Tob	Unit Weight: 130 pcf	Cohesion: 50 psf	Phi: 10 °
Name: Qal	Unit Weight: 130 pcf	Cohesion: 200 psf	Phi: 23 °
Name: Qls	Unit Weight: 130 pcf	Cohesion: 200 psf	Phi: 23 °
Name: Mzu	Unit Weight: 130 pcf	Cohesion: 0 psf	Phi: 35 °

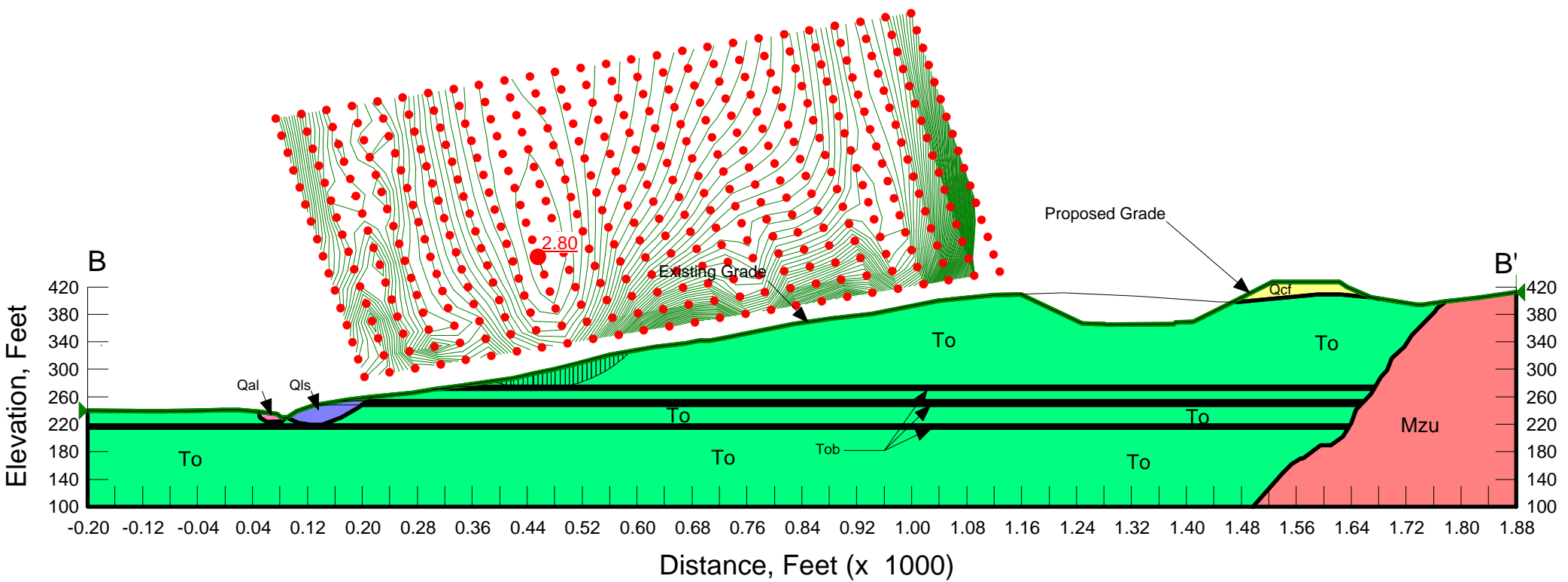

Figure D-11

Otay Ranch Village 4
 Project No. G1806-11-01
 Section B-B'
 Name: B-B' Case 1b.gsz
 Date: 3/9/2015 Time: 3:28:07 PM

Material Properties:

Name: Qcf	Unit Weight: 130 pcf	Cohesion: 300 psf	Phi: 28 °	Piezometric Line: 1
Name: To	Unit Weight: 130 pcf	Cohesion: 325 psf	Phi: 33 °	Piezometric Line: 1
Name: Tob	Unit Weight: 130 pcf	Cohesion: 50 psf	Phi: 10 °	Piezometric Line: 1
Name: Qal	Unit Weight: 130 pcf	Cohesion: 200 psf	Phi: 23 °	Piezometric Line: 1
Name: Qls	Unit Weight: 130 pcf	Cohesion: 200 psf	Phi: 23 °	Piezometric Line: 1
Name: Mzu	Unit Weight: 130 pcf	Cohesion: 0 psf	Phi: 35 °	Piezometric Line: 1

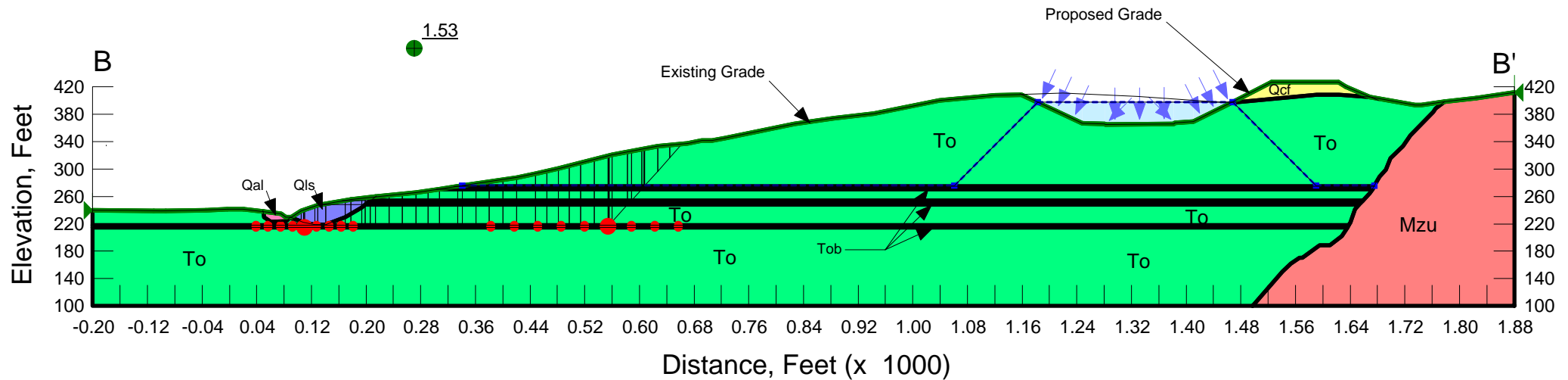

Figure D-12

Otay Ranch Village 4
 Project No. G1806-11-01
 Section B-B'
 Name: B-B' Case 2b.gsz
 Date: 3/9/2015 Time: 3:32:15 PM

Material Properties:

Name: Qcf	Unit Weight: 130 pcf	Cohesion: 300 psf	Phi: 28 °	Piezometric Line: 1
Name: To	Unit Weight: 130 pcf	Cohesion: 325 psf	Phi: 33 °	Piezometric Line: 1
Name: Tob	Unit Weight: 130 pcf	Cohesion: 50 psf	Phi: 10 °	Piezometric Line: 1
Name: Qal	Unit Weight: 130 pcf	Cohesion: 200 psf	Phi: 23 °	Piezometric Line: 1
Name: Qls	Unit Weight: 130 pcf	Cohesion: 200 psf	Phi: 23 °	Piezometric Line: 1
Name: Mzu	Unit Weight: 130 pcf	Cohesion: 0 psf	Phi: 35 °	Piezometric Line: 1

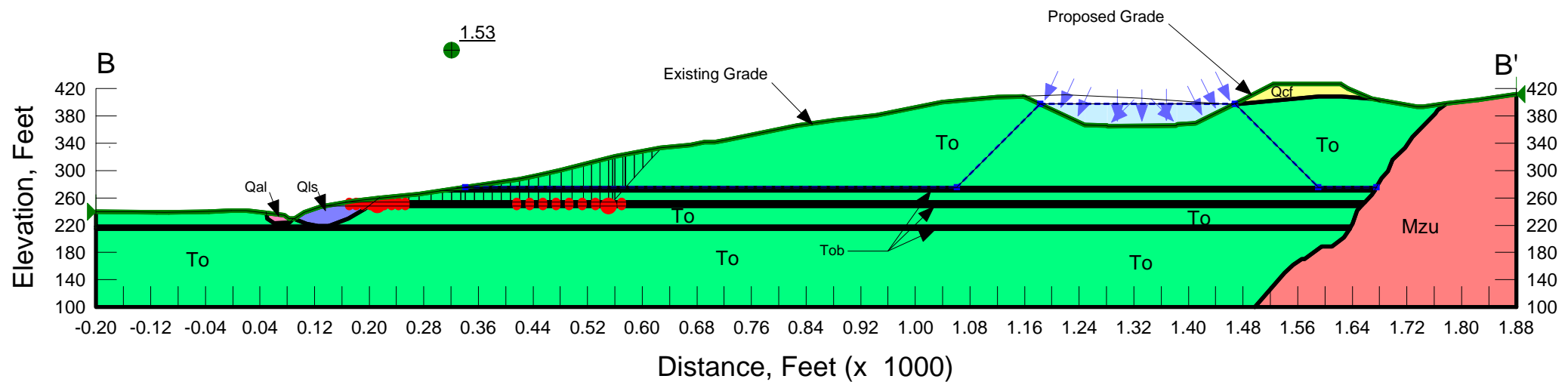

Figure D-13

Otay Ranch Village 4
 Project No. G1806-11-01
 Section B-B'
 Name: B-B' Case 3b.gsz
 Date: 3/9/2015 Time: 3:36:20 PM

Material Properties:

Name: Qcf	Unit Weight: 130 pcf	Cohesion: 300 psf	Phi: 28 °	Piezometric Line: 1
Name: To	Unit Weight: 130 pcf	Cohesion: 325 psf	Phi: 33 °	Piezometric Line: 1
Name: Tob	Unit Weight: 130 pcf	Cohesion: 50 psf	Phi: 10 °	Piezometric Line: 1
Name: Qal	Unit Weight: 130 pcf	Cohesion: 200 psf	Phi: 23 °	Piezometric Line: 1
Name: Qls	Unit Weight: 130 pcf	Cohesion: 200 psf	Phi: 23 °	Piezometric Line: 1
Name: Mzu	Unit Weight: 130 pcf	Cohesion: 0 psf	Phi: 35 °	Piezometric Line: 1

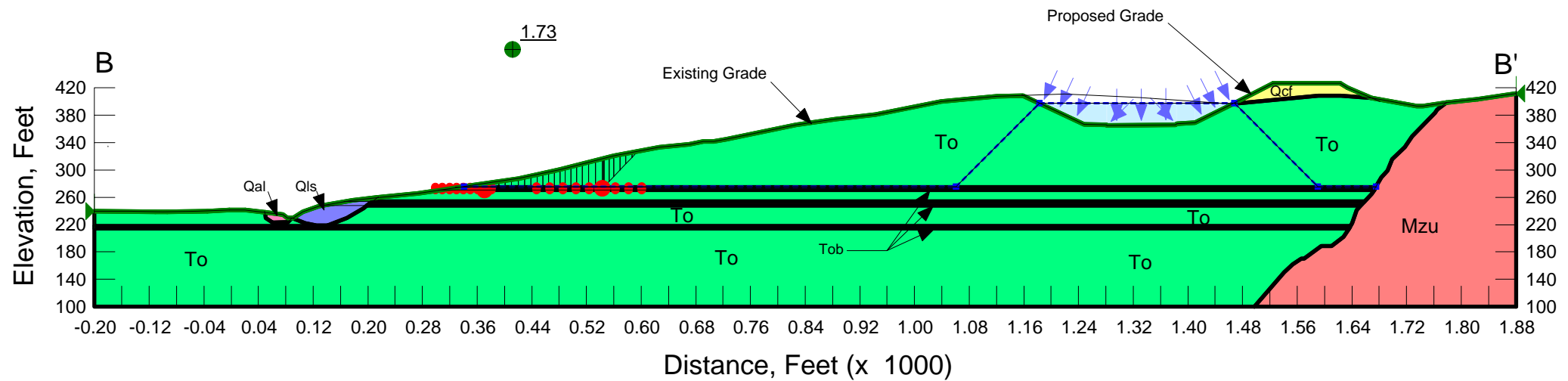

Figure D-14

Otay Ranch Village 4
 Project No. G1806-11-01
 Section B-B'
 Name: B-B' Case 4b.gsz
 Date: 3/9/2015 Time: 3:47:52 PM

Material Properties:

Name: Qcf	Unit Weight: 130 pcf	Cohesion: 300 psf	Phi: 28 °	Piezometric Line: 1
Name: To	Unit Weight: 130 pcf	Cohesion: 325 psf	Phi: 33 °	Piezometric Line: 1
Name: Tob	Unit Weight: 130 pcf	Cohesion: 50 psf	Phi: 10 °	Piezometric Line: 1
Name: Qal	Unit Weight: 130 pcf	Cohesion: 200 psf	Phi: 23 °	Piezometric Line: 1
Name: Qls	Unit Weight: 130 pcf	Cohesion: 200 psf	Phi: 23 °	Piezometric Line: 1
Name: Mzu	Unit Weight: 130 pcf	Cohesion: 0 psf	Phi: 35 °	Piezometric Line: 1

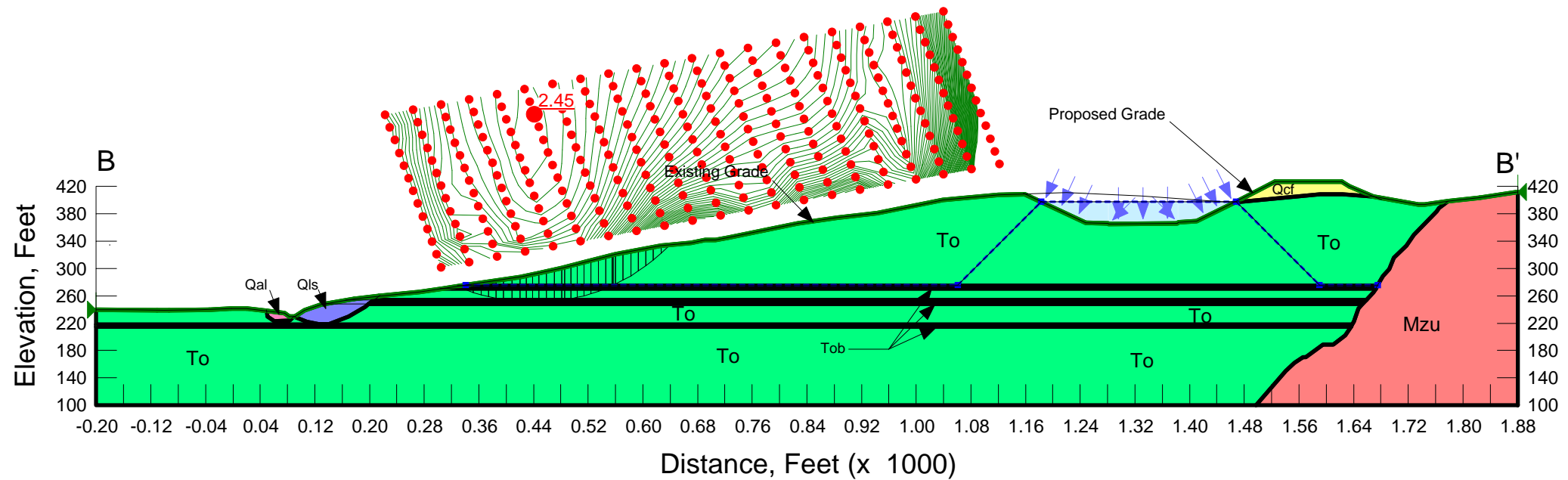

Figure D-15

Otay Ranch Village 4
 Project No. G1806-11-01
 Section C-C'
 Name: C-C' Case 2.gsz
 Date: 3/9/2015 Time: 2:43:08 PM

Material Properties:

Name: Qcf	Unit Weight: 130 pcf	Cohesion: 300 psf	Phi: 28 °
Name: To	Unit Weight: 130 pcf	Cohesion: 325 psf	Phi: 33 °
Name: Tob	Unit Weight: 130 pcf	Cohesion: 50 psf	Phi: 10 °
Name: Qal	Unit Weight: 130 pcf	Cohesion: 200 psf	Phi: 23 °

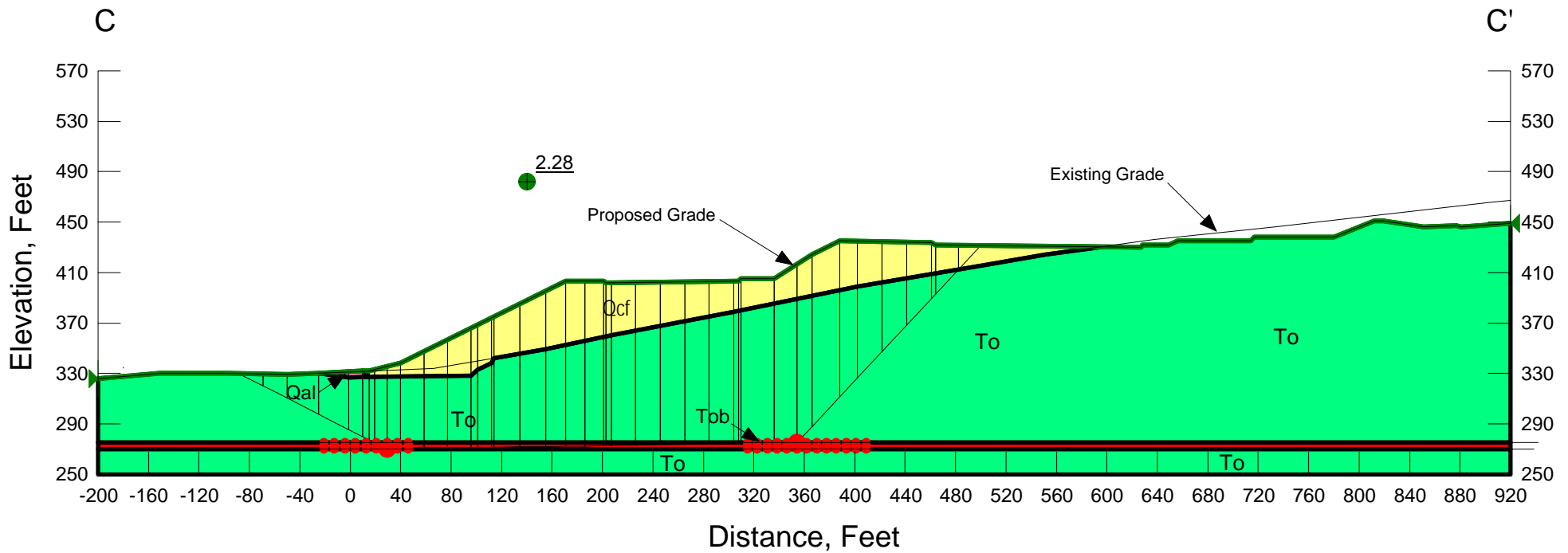

Figure D-16

Otay Ranch Village 4
 Project No. G1806-11-01
 Section C-C'
 Name: C-C' Case 1.gsz
 Date: 3/9/2015 Time: 2:40:53 PM

Material Properties:

Name: Qcf	Unit Weight: 130 pcf	Cohesion: 300 psf	Phi: 28 °
Name: To	Unit Weight: 130 pcf	Cohesion: 325 psf	Phi: 33 °
Name: Tob	Unit Weight: 130 pcf	Cohesion: 50 psf	Phi: 10 °
Name: Qal	Unit Weight: 130 pcf	Cohesion: 200 psf	Phi: 23 °

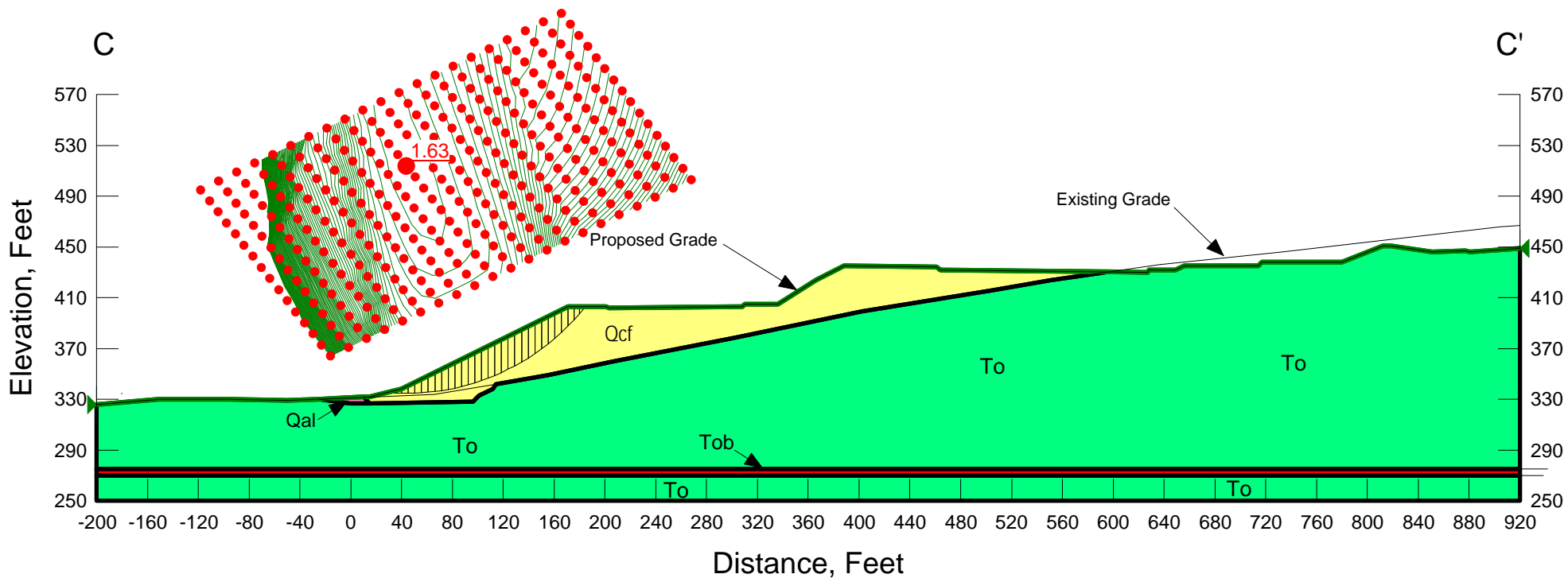

Figure D-17

Otay Ranch Village 4
 Project No. G1806-11-01
 Section D-D'
 Name: D-D' Case 2.gsz
 Date: 3/9/2015 Time: 10:59:40 AM

Material Properties:

Name: Qcf	Unit Weight: 130 pcf	Cohesion: 300 psf	Phi: 28 °
Name: To	Unit Weight: 130 pcf	Cohesion: 325 psf	Phi: 33 °
Name: Tob	Unit Weight: 130 pcf	Cohesion: 50 psf	Phi: 10 °
Name: Qal	Unit Weight: 130 pcf	Cohesion: 200 psf	Phi: 23 °
Name: Mzu	Unit Weight: 130 pcf	Cohesion: 0 psf	Phi: 35 °

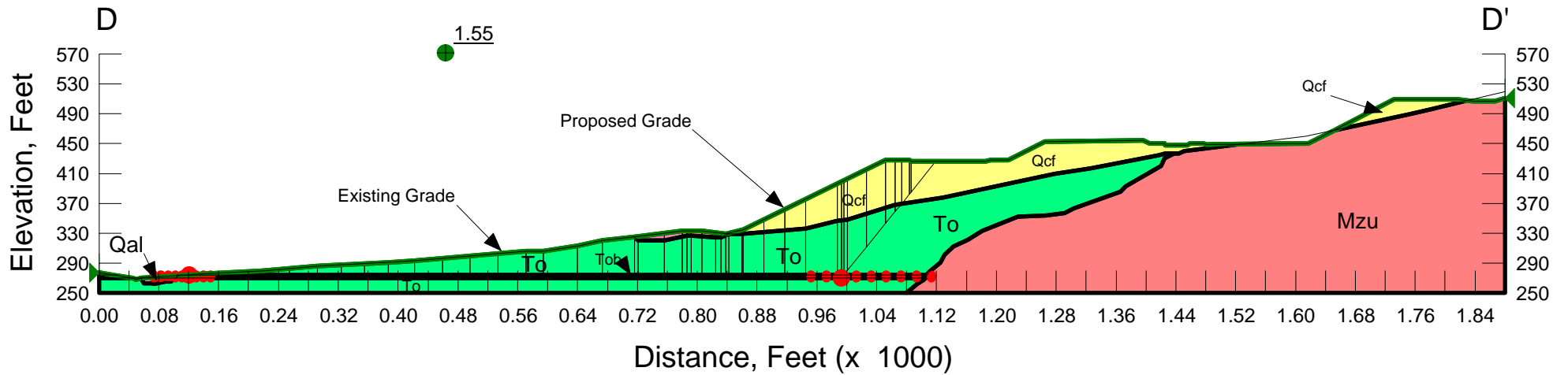

Figure D-18

Otay Ranch Village 4
 Project No. G1806-11-01
 Section D-D'
 Name: D-D' Case 1.gsz
 Date: 3/9/2015 Time: 10:51:06 AM

Material Properties:

Name: Qcf	Unit Weight: 130 pcf	Cohesion: 300 psf	Phi: 28 °
Name: To	Unit Weight: 130 pcf	Cohesion: 325 psf	Phi: 33 °
Name: Tob	Unit Weight: 130 pcf	Cohesion: 50 psf	Phi: 10 °
Name: Qal	Unit Weight: 130 pcf	Cohesion: 200 psf	Phi: 23 °
Name: Mzu	Unit Weight: 130 pcf	Cohesion: 0 psf	Phi: 35 °

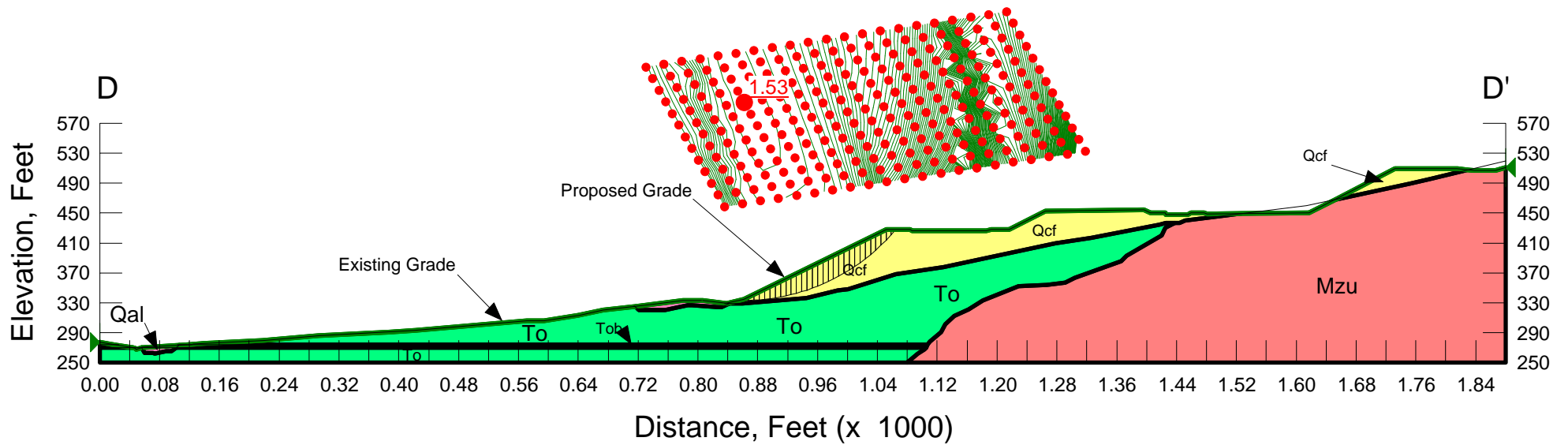

Figure D-19

Otay Ranch Village 4
 Project No. G1806-11-01
 Section E-E'
 Name: E-E' Case 2.gsz
 Date: 3/9/2015 Time: 4:10:53 PM

Material Properties:

Name: Qcf Unit Weight: 130 pcf Cohesion: 300 psf Phi: 28 °
 Name: To Unit Weight: 130 pcf Cohesion: 325 psf Phi: 33 °
 Name: Tob Unit Weight: 130 pcf Cohesion: 50 psf Phi: 10 °
 Name: Qal Unit Weight: 130 pcf Cohesion: 200 psf Phi: 23 °
 Name: Mzu Unit Weight: 130 pcf Cohesion: 0 psf Phi: 35 °

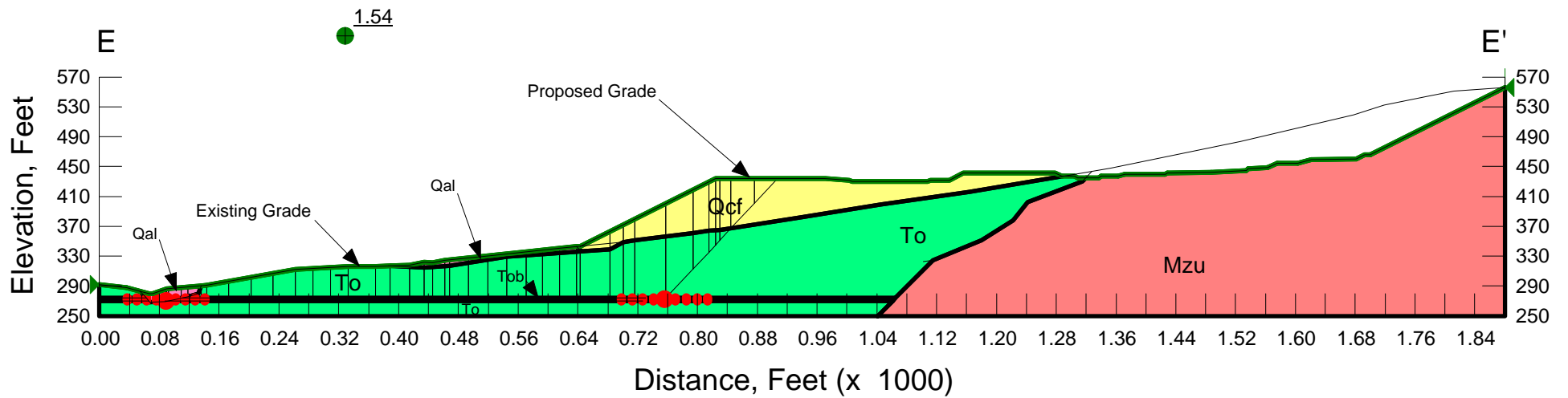

Figure D-20

Otay Ranch Village 4
 Project No. G1806-11-01
 Section E-E'
 Name: E-E' Case 1.gsz
 Date: 3/9/2015 Time: 4:07:44 PM

Material Properties:

Name: Qcf	Unit Weight: 130 pcf	Cohesion: 300 psf	Phi: 28 °
Name: To	Unit Weight: 130 pcf	Cohesion: 325 psf	Phi: 33 °
Name: Tob	Unit Weight: 130 pcf	Cohesion: 50 psf	Phi: 10 °
Name: Qal	Unit Weight: 130 pcf	Cohesion: 200 psf	Phi: 23 °
Name: Mzu	Unit Weight: 130 pcf	Cohesion: 0 psf	Phi: 35 °

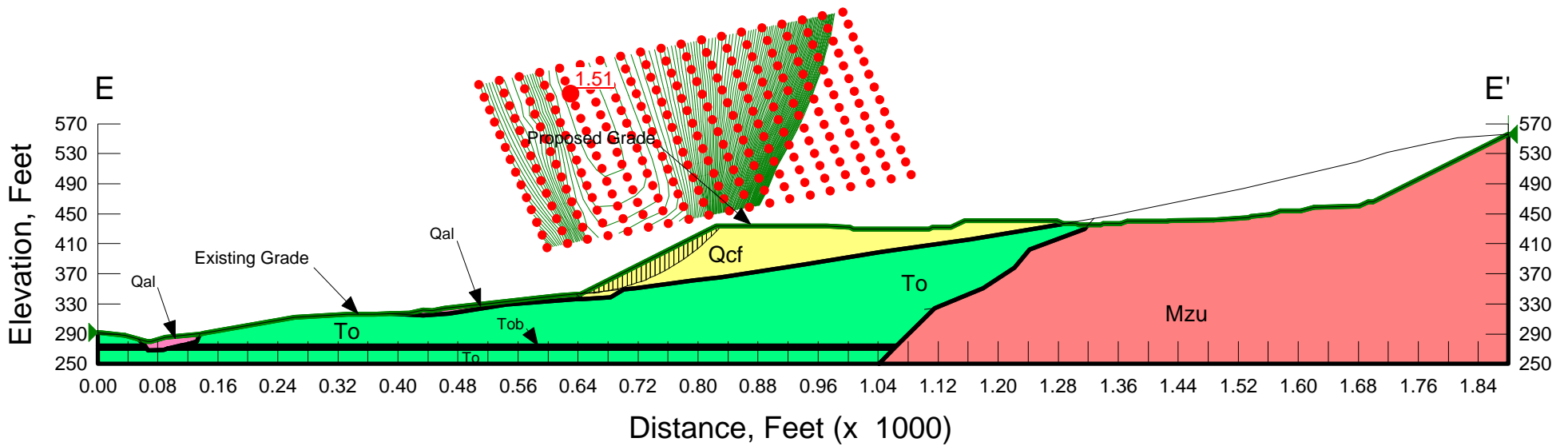

Figure D-21

ASSUMED CONDITIONS :

SLOPE HEIGHT	H = Infinite
DEPTH OF SATURATION	Z = 3 feet
SLOPE INCLINATION	2 : 1 (Horizontal : Vertical)
SLOPE ANGLE	i = 26.6 degrees
UNIT WEIGHT OF WATER	γ_w = 62.4 pounds per cubic foot
TOTAL UNIT WEIGHT OF SOIL	γ_t = 130 pounds per cubic foot
ANGLE OF INTERNAL FRICTION	ϕ = 28 degrees
APPARENT COHESION	C = 300 pounds per square foot

SLOPE SATURATED TO VERTICAL DEPTH Z BELOW SLOPE FACE

SEEPAGE FORCES PARALLEL TO SLOPE FACE

ANALYSIS :

$$FS = \frac{C + (\gamma_t - \gamma_w) Z \cos^2 i \tan \phi}{\gamma_t Z \sin i \cos i} = 2.5$$

REFERENCES :

- 1.....Haefeli, R. *The Stability of Slopes Acted Upon by Parallel Seepage*, Proc. Second International Conference, SMFE, Rotterdam, 1948, 1, 57-62
- 2.....Skempton, A. W., and F.A. Delory, *Stability of Natural Slopes in London Clay*, Proc. Fourth International Conference, SMFE, London, 1957, 2, 378-81

SURFICIAL SLOPE STABILITY ANALYSIS

GEOCON
INCORPORATED



GEOTECHNICAL ■ ENVIRONMENTAL ■ MATERIALS
6960 FLANDERS DRIVE - SAN DIEGO, CALIFORNIA 92121 - 2974
PHONE 858 558-6900 - FAX 858 558-6159

OTAY RANCH VILLAGE 4
CHULA VISTA, CALIFORNIA

RM / AML

DSK/GTYPD

DATE

PROJECT NO. G1806 - 11 - 01

FIG. D-22

APPENDIX

A solid green triangle pointing to the left, containing the letter 'E' in white.

E

APPENDIX E

RECOMMENDED GRADING SPECIFICATIONS

FOR

OTAY RANCH VILLAGE 4
CHULA VISTA, CALIFORNIA

PROJECT NO. G1806-11-01

RECOMMENDED GRADING SPECIFICATIONS

1. GENERAL

- 1.1 These Recommended Grading Specifications shall be used in conjunction with the Geotechnical Report for the project prepared by Geocon Incorporated. The recommendations contained in the text of the Geotechnical Report are a part of the earthwork and grading specifications and shall supersede the provisions contained hereinafter in the case of conflict.
- 1.2 Prior to the commencement of grading, a geotechnical consultant (Consultant) shall be employed for the purpose of observing earthwork procedures and testing the fills for substantial conformance with the recommendations of the Geotechnical Report and these specifications. The Consultant should provide adequate testing and observation services so that they may assess whether, in their opinion, the work was performed in substantial conformance with these specifications. It shall be the responsibility of the Contractor to assist the Consultant and keep them apprised of work schedules and changes so that personnel may be scheduled accordingly.
- 1.3 It shall be the sole responsibility of the Contractor to provide adequate equipment and methods to accomplish the work in accordance with applicable grading codes or agency ordinances, these specifications and the approved grading plans. If, in the opinion of the Consultant, unsatisfactory conditions such as questionable soil materials, poor moisture condition, inadequate compaction, adverse weather, result in a quality of work not in conformance with these specifications, the Consultant will be empowered to reject the work and recommend to the Owner that grading be stopped until the unacceptable conditions are corrected.

2. DEFINITIONS

- 2.1 **Owner** shall refer to the owner of the property or the entity on whose behalf the grading work is being performed and who has contracted with the Contractor to have grading performed.
- 2.2 **Contractor** shall refer to the Contractor performing the site grading work.
- 2.3 **Civil Engineer** or **Engineer of Work** shall refer to the California licensed Civil Engineer or consulting firm responsible for preparation of the grading plans, surveying and verifying as-graded topography.

- 2.4 **Consultant** shall refer to the soil engineering and engineering geology consulting firm retained to provide geotechnical services for the project.
- 2.5 **Soil Engineer** shall refer to a California licensed Civil Engineer retained by the Owner, who is experienced in the practice of geotechnical engineering. The Soil Engineer shall be responsible for having qualified representatives on-site to observe and test the Contractor's work for conformance with these specifications.
- 2.6 **Engineering Geologist** shall refer to a California licensed Engineering Geologist retained by the Owner to provide geologic observations and recommendations during the site grading.
- 2.7 **Geotechnical Report** shall refer to a soil report (including all addenda) which may include a geologic reconnaissance or geologic investigation that was prepared specifically for the development of the project for which these Recommended Grading Specifications are intended to apply.

3. MATERIALS

- 3.1 Materials for compacted fill shall consist of any soil excavated from the cut areas or imported to the site that, in the opinion of the Consultant, is suitable for use in construction of fills. In general, fill materials can be classified as *soil* fills, *soil-rock* fills or *rock* fills, as defined below.
- 3.1.1 **Soil fills** are defined as fills containing no rocks or hard lumps greater than 12 inches in maximum dimension and containing at least 40 percent by weight of material smaller than $\frac{3}{4}$ inch in size.
- 3.1.2 **Soil-rock fills** are defined as fills containing no rocks or hard lumps larger than 4 feet in maximum dimension and containing a sufficient matrix of soil fill to allow for proper compaction of soil fill around the rock fragments or hard lumps as specified in Paragraph 6.2. **Oversize rock** is defined as material greater than 12 inches.
- 3.1.3 **Rock fills** are defined as fills containing no rocks or hard lumps larger than 3 feet in maximum dimension and containing little or no fines. Fines are defined as material smaller than $\frac{3}{4}$ inch in maximum dimension. The quantity of fines shall be less than approximately 20 percent of the rock fill quantity.

- 3.2 Material of a perishable, spongy, or otherwise unsuitable nature as determined by the Consultant shall not be used in fills.
- 3.3 Materials used for fill, either imported or on-site, shall not contain hazardous materials as defined by the California Code of Regulations, Title 22, Division 4, Chapter 30, Articles 9 and 10; 40CFR; and any other applicable local, state or federal laws. The Consultant shall not be responsible for the identification or analysis of the potential presence of hazardous materials. However, if observations, odors or soil discoloration cause Consultant to suspect the presence of hazardous materials, the Consultant may request from the Owner the termination of grading operations within the affected area. Prior to resuming grading operations, the Owner shall provide a written report to the Consultant indicating that the suspected materials are not hazardous as defined by applicable laws and regulations.
- 3.4 The outer 15 feet of *soil-rock* fill slopes, measured horizontally, should be composed of properly compacted *soil* fill materials approved by the Consultant. *Rock* fill may extend to the slope face, provided that the slope is not steeper than 2:1 (horizontal:vertical) and a soil layer no thicker than 12 inches is track-walked onto the face for landscaping purposes. This procedure may be utilized provided it is acceptable to the governing agency, Owner and Consultant.
- 3.5 Samples of soil materials to be used for fill should be tested in the laboratory by the Consultant to determine the maximum density, optimum moisture content, and, where appropriate, shear strength, expansion, and gradation characteristics of the soil.
- 3.6 During grading, soil or groundwater conditions other than those identified in the Geotechnical Report may be encountered by the Contractor. The Consultant shall be notified immediately to evaluate the significance of the unanticipated condition

4. CLEARING AND PREPARING AREAS TO BE FILLED

- 4.1 Areas to be excavated and filled shall be cleared and grubbed. Clearing shall consist of complete removal above the ground surface of trees, stumps, brush, vegetation, man-made structures, and similar debris. Grubbing shall consist of removal of stumps, roots, buried logs and other unsuitable material and shall be performed in areas to be graded. Roots and other projections exceeding 1½ inches in diameter shall be removed to a depth of 3 feet below the surface of the ground. Borrow areas shall be grubbed to the extent necessary to provide suitable fill materials.

- 4.2 Any asphalt pavement material removed during clearing operations should be properly disposed at an approved off-site facility. Concrete fragments that are free of reinforcing steel may be placed in fills, provided they are placed in accordance with Section 6.2 or 6.3 of this document.
- 4.3 After clearing and grubbing of organic matter and other unsuitable material, loose or porous soils shall be removed to the depth recommended in the Geotechnical Report. The depth of removal and compaction should be observed and approved by a representative of the Consultant. The exposed surface shall then be plowed or scarified to a minimum depth of 6 inches and until the surface is free from uneven features that would tend to prevent uniform compaction by the equipment to be used.
- 4.4 Where the slope ratio of the original ground is steeper than 5:1 (horizontal:vertical), or where recommended by the Consultant, the original ground should be benched in accordance with the following illustration.

TYPICAL BENCHING DETAIL

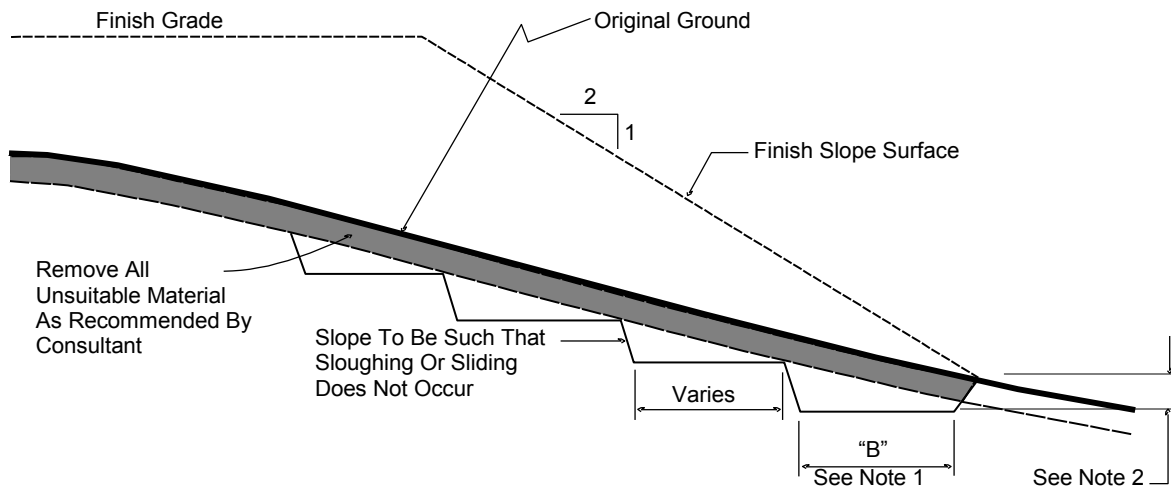

No Scale

- DETAIL NOTES:
- (1) Key width "B" should be a minimum of 10 feet, or sufficiently wide to permit complete coverage with the compaction equipment used. The base of the key should be graded horizontal, or inclined slightly into the natural slope.
 - (2) The outside of the key should be below the topsoil or unsuitable surficial material and at least 2 feet into dense formational material. Where hard rock is exposed in the bottom of the key, the depth and configuration of the key may be modified as approved by the Consultant.

- 4.5 After areas to receive fill have been cleared and scarified, the surface should be moisture conditioned to achieve the proper moisture content, and compacted as recommended in Section 6 of these specifications.

5. COMPACTION EQUIPMENT

- 5.1 Compaction of *soil* or *soil-rock* fill shall be accomplished by sheepsfoot or segmented-steel wheeled rollers, vibratory rollers, multiple-wheel pneumatic-tired rollers, or other types of acceptable compaction equipment. Equipment shall be of such a design that it will be capable of compacting the *soil* or *soil-rock* fill to the specified relative compaction at the specified moisture content.
- 5.2 Compaction of *rock* fills shall be performed in accordance with Section 6.3.

6. PLACING, SPREADING AND COMPACTION OF FILL MATERIAL

- 6.1 *Soil* fill, as defined in Paragraph 3.1.1, shall be placed by the Contractor in accordance with the following recommendations:
- 6.1.1 *Soil* fill shall be placed by the Contractor in layers that, when compacted, should generally not exceed 8 inches. Each layer shall be spread evenly and shall be thoroughly mixed during spreading to obtain uniformity of material and moisture in each layer. The entire fill shall be constructed as a unit in nearly level lifts. Rock materials greater than 12 inches in maximum dimension shall be placed in accordance with Section 6.2 or 6.3 of these specifications.
- 6.1.2 In general, the *soil* fill shall be compacted at a moisture content at or above the optimum moisture content as determined by ASTM D 1557-09.
- 6.1.3 When the moisture content of *soil* fill is below that specified by the Consultant, water shall be added by the Contractor until the moisture content is in the range specified.
- 6.1.4 When the moisture content of the *soil* fill is above the range specified by the Consultant or too wet to achieve proper compaction, the *soil* fill shall be aerated by the Contractor by blading/mixing, or other satisfactory methods until the moisture content is within the range specified.

- 6.1.5 After each layer has been placed, mixed, and spread evenly, it shall be thoroughly compacted by the Contractor to a relative compaction of at least 90 percent. Relative compaction is defined as the ratio (expressed in percent) of the in-place dry density of the compacted fill to the maximum laboratory dry density as determined in accordance with ASTM D 1557-09. Compaction shall be continuous over the entire area, and compaction equipment shall make sufficient passes so that the specified minimum relative compaction has been achieved throughout the entire fill.
- 6.1.6 Where practical, soils having an Expansion Index greater than 50 should be placed at least 3 feet below finish pad grade and should be compacted at a moisture content generally 2 to 4 percent greater than the optimum moisture content for the material.
- 6.1.7 Properly compacted *soil* fill shall extend to the design surface of fill slopes. To achieve proper compaction, it is recommended that fill slopes be over-built by at least 3 feet and then cut to the design grade. This procedure is considered preferable to track-walking of slopes, as described in the following paragraph.
- 6.1.8 As an alternative to over-building of slopes, slope faces may be back-rolled with a heavy-duty loaded sheepsfoot or vibratory roller at maximum 4-foot fill height intervals. Upon completion, slopes should then be track-walked with a D-8 dozer or similar equipment, such that a dozer track covers all slope surfaces at least twice.
- 6.2 *Soil-rock* fill, as defined in Paragraph 3.1.2, shall be placed by the Contractor in accordance with the following recommendations:
- 6.2.1 Rocks larger than 12 inches but less than 4 feet in maximum dimension may be incorporated into the compacted *soil* fill, but shall be limited to the area measured 15 feet minimum horizontally from the slope face and 5 feet below finish grade or 3 feet below the deepest utility, whichever is deeper.
- 6.2.2 Rocks or rock fragments up to 4 feet in maximum dimension may either be individually placed or placed in windrows. Under certain conditions, rocks or rock fragments up to 10 feet in maximum dimension may be placed using similar methods. The acceptability of placing rock materials greater than 4 feet in maximum dimension shall be evaluated during grading as specific cases arise and shall be approved by the Consultant prior to placement.

- 6.2.3 For individual placement, sufficient space shall be provided between rocks to allow for passage of compaction equipment.
 - 6.2.4 For windrow placement, the rocks should be placed in trenches excavated in properly compacted *soil* fill. Trenches should be approximately 5 feet wide and 4 feet deep in maximum dimension. The voids around and beneath rocks should be filled with approved granular soil having a Sand Equivalent of 30 or greater and should be compacted by flooding. Windrows may also be placed utilizing an "open-face" method in lieu of the trench procedure, however, this method should first be approved by the Consultant.
 - 6.2.5 Windrows should generally be parallel to each other and may be placed either parallel to or perpendicular to the face of the slope depending on the site geometry. The minimum horizontal spacing for windrows shall be 12 feet center-to-center with a 5-foot stagger or offset from lower courses to next overlying course. The minimum vertical spacing between windrow courses shall be 2 feet from the top of a lower windrow to the bottom of the next higher windrow.
 - 6.2.6 Rock placement, fill placement and flooding of approved granular soil in the windrows should be continuously observed by the Consultant.
- 6.3 *Rock* fills, as defined in Section 3.1.3, shall be placed by the Contractor in accordance with the following recommendations:
- 6.3.1 The base of the *rock* fill shall be placed on a sloping surface (minimum slope of 2 percent). The surface shall slope toward suitable subdrainage outlet facilities. The *rock* fills shall be provided with subdrains during construction so that a hydrostatic pressure buildup does not develop. The subdrains shall be permanently connected to controlled drainage facilities to control post-construction infiltration of water.
 - 6.3.2 *Rock* fills shall be placed in lifts not exceeding 3 feet. Placement shall be by rock trucks traversing previously placed lifts and dumping at the edge of the currently placed lift. Spreading of the *rock* fill shall be by dozer to facilitate *seating* of the rock. The *rock* fill shall be watered heavily during placement. Watering shall consist of water trucks traversing in front of the current rock lift face and spraying water continuously during rock placement. Compaction equipment with compactive energy comparable to or greater than that of a 20-ton steel vibratory roller or other compaction equipment providing suitable energy to achieve the

required compaction or deflection as recommended in Paragraph 6.3.3 shall be utilized. The number of passes to be made should be determined as described in Paragraph 6.3.3. Once a *rock* fill lift has been covered with *soil* fill, no additional *rock* fill lifts will be permitted over the *soil* fill.

- 6.3.3 Plate bearing tests, in accordance with ASTM D 1196-09, may be performed in both the compacted *soil* fill and in the *rock* fill to aid in determining the required minimum number of passes of the compaction equipment. If performed, a minimum of three plate bearing tests should be performed in the properly compacted *soil* fill (minimum relative compaction of 90 percent). Plate bearing tests shall then be performed on areas of *rock* fill having two passes, four passes and six passes of the compaction equipment, respectively. The number of passes required for the *rock* fill shall be determined by comparing the results of the plate bearing tests for the *soil* fill and the *rock* fill and by evaluating the deflection variation with number of passes. The required number of passes of the compaction equipment will be performed as necessary until the plate bearing deflections are equal to or less than that determined for the properly compacted *soil* fill. In no case will the required number of passes be less than two.
- 6.3.4 A representative of the Consultant should be present during *rock* fill operations to observe that the minimum number of “passes” have been obtained, that water is being properly applied and that specified procedures are being followed. The actual number of plate bearing tests will be determined by the Consultant during grading.
- 6.3.5 Test pits shall be excavated by the Contractor so that the Consultant can state that, in their opinion, sufficient water is present and that voids between large rocks are properly filled with smaller rock material. In-place density testing will not be required in the *rock* fills.
- 6.3.6 To reduce the potential for “piping” of fines into the *rock* fill from overlying *soil* fill material, a 2-foot layer of graded filter material shall be placed above the uppermost lift of *rock* fill. The need to place graded filter material below the *rock* should be determined by the Consultant prior to commencing grading. The gradation of the graded filter material will be determined at the time the *rock* fill is being excavated. Materials typical of the *rock* fill should be submitted to the Consultant in a timely manner, to allow design of the graded filter prior to the commencement of *rock* fill placement.
- 6.3.7 *Rock* fill placement should be continuously observed during placement by the Consultant.

7. OBSERVATION AND TESTING

- 7.1 The Consultant shall be the Owner's representative to observe and perform tests during clearing, grubbing, filling, and compaction operations. In general, no more than 2 feet in vertical elevation of *soil* or *soil-rock* fill should be placed without at least one field density test being performed within that interval. In addition, a minimum of one field density test should be performed for every 2,000 cubic yards of *soil* or *soil-rock* fill placed and compacted.
- 7.2 The Consultant should perform a sufficient distribution of field density tests of the compacted *soil* or *soil-rock* fill to provide a basis for expressing an opinion whether the fill material is compacted as specified. Density tests shall be performed in the compacted materials below any disturbed surface. When these tests indicate that the density of any layer of fill or portion thereof is below that specified, the particular layer or areas represented by the test shall be reworked until the specified density has been achieved.
- 7.3 During placement of *rock* fill, the Consultant should observe that the minimum number of passes have been obtained per the criteria discussed in Section 6.3.3. The Consultant should request the excavation of observation pits and may perform plate bearing tests on the placed *rock* fills. The observation pits will be excavated to provide a basis for expressing an opinion as to whether the *rock* fill is properly seated and sufficient moisture has been applied to the material. When observations indicate that a layer of *rock* fill or any portion thereof is below that specified, the affected layer or area shall be reworked until the *rock* fill has been adequately seated and sufficient moisture applied.
- 7.4 A settlement monitoring program designed by the Consultant may be conducted in areas of *rock* fill placement. The specific design of the monitoring program shall be as recommended in the Conclusions and Recommendations section of the project Geotechnical Report or in the final report of testing and observation services performed during grading.
- 7.5 The Consultant should observe the placement of subdrains, to verify that the drainage devices have been placed and constructed in substantial conformance with project specifications.
- 7.6 Testing procedures shall conform to the following Standards as appropriate:

7.6.1 Soil and Soil-Rock Fills:

- 7.6.1.1 Field Density Test, ASTM D 1556-07, *Density of Soil In-Place By the Sand-Cone Method.*
- 7.6.1.2 Field Density Test, Nuclear Method, ASTM D 6938-08A, *Density of Soil and Soil-Aggregate In-Place by Nuclear Methods (Shallow Depth).*
- 7.6.1.3 Laboratory Compaction Test, ASTM D 1557-09, *Moisture-Density Relations of Soils and Soil-Aggregate Mixtures Using 10-Pound Hammer and 18-Inch Drop.*
- 7.6.1.4. Expansion Index Test, ASTM D 4829-08A, *Expansion Index Test.*

7.6.2 Rock Fills

- 7.6.2.1 Field Plate Bearing Test, ASTM D 1196-09 (Reapproved 1997) *Standard Method for Nonreparative Static Plate Load Tests of Soils and Flexible Pavement Components, For Use in Evaluation and Design of Airport and Highway Pavements.*

8. PROTECTION OF WORK

- 8.1 During construction, the Contractor shall properly grade all excavated surfaces to provide positive drainage and prevent ponding of water. Drainage of surface water shall be controlled to avoid damage to adjoining properties or to finished work on the site. The Contractor shall take remedial measures to prevent erosion of freshly graded areas until such time as permanent drainage and erosion control features have been installed. Areas subjected to erosion or sedimentation shall be properly prepared in accordance with the Specifications prior to placing additional fill or structures.
- 8.2 After completion of grading as observed and tested by the Consultant, no further excavation or filling shall be conducted except in conjunction with the services of the Consultant.

9. CERTIFICATIONS AND FINAL REPORTS

- 9.1 Upon completion of the work, Contractor shall furnish Owner a certification by the Civil Engineer stating that the lots and/or building pads are graded to within 0.1 foot vertically of elevations shown on the grading plan and that all tops and toes of slopes are within 0.5 foot horizontally of the positions shown on the grading plans. After installation of a section of subdrain, the project Civil Engineer should survey its location and prepare an *as-built* plan of the subdrain location. The project Civil Engineer should verify the proper outlet for the subdrains and the Contractor should ensure that the drain system is free of obstructions.
- 9.2 The Owner is responsible for furnishing a final as-graded soil and geologic report satisfactory to the appropriate governing or accepting agencies. The as-graded report should be prepared and signed by a California licensed Civil Engineer experienced in geotechnical engineering and by a California Certified Engineering Geologist, indicating that the geotechnical aspects of the grading were performed in substantial conformance with the Specifications or approved changes to the Specifications.

LIST OF REFERENCES

1. *2013 California Building Code, California Code of Regulations, Title 24, Part 2, based on the 2012 International Building Code*, prepared by California Building Standards Commission, dated July, 2013.
2. *ACI 318-11, Building Code Requirements for Structural Concrete and Commentary*, prepared by the American Concrete Institute, dated August, 2011.
3. *ACI 330-08, Guide for the Design and Construction of Concrete Parking Lots*, prepared by the American Concrete Institute, dated June, 2008.
4. Afrouz, A. A., 1992, *Practical Handbook of Rock Mass Classifications and Modes of Ground Failure*, CRC Press.
5. American Geological Institute, 1982, *AGI Data Sheets for Geology in the Field, Laboratory, and Office*, second edition, Data Sheet 58.2.
6. ASCE 7-10, *Minimum Design Loads for Buildings and Other Structures, Second Printing*, April 6, 2011.
7. Bieniawski, Z. T., 1989, *Engineering Rock Mass Classifications*, Wiley: New York.
8. Boore, D. M. and G. M. Atkinson (2008), *Ground-Motion Prediction for the Average Horizontal Component of PGA, PGV, and 5%-Damped PSA at Spectral Periods Between 0.01 and 10.0 S*, Earthquake Spectra, Volume 24, Issue 1, pages 99-138, February 2008.
9. California Division on Mines and Geology, *Geology of National City, Imperial Beach, and Otay Mesa Quadrangles, Southern San Diego Metropolitan Area, California*, Michael P. Kennedy and Siang S. Tan, 1977.
10. California Geologic Survey (CGS), *Geologic Map of the Otay Mesa 7.5' Quadrangle, San Diego County, California*, CGS and USGS, 2002.
11. California Geological Survey (CGS), 2003, *Earthquake Shaking Potential for California*, from USGS/CGS Seismic Hazards Model, CSSC No. 03-02.
12. California Geologic Survey, *Seismic Shaking Hazards in California*, Based on the USGS/CGS Probabilistic Seismic Hazards Assessment (PSHA) Model, edited May 9, 2010. 10% probability of being exceeded in 50 years.
<http://redirect.conservation.ca.gov/cgs/rghm/pshamap/pshamap.asp>
13. Campbell, K. W. and Y. Bozorgnia, *NGA Ground Motion Model for the Geometric Mean Horizontal Component of PGA, PGV, PGD and 5% Damped Linear Elastic Response Spectra for Periods Ranging from 0.01 to 10 s*, Preprint of version submitted for publication in the NGA Special Volume of Earthquake Spectra, Volume 24, Issue 1, pages 139-171, February 2008.
14. Chiou, Brian S.J. and Robert R. Youngs, *A NGA Model for the Average Horizontal Component of Peak Ground Motion and Response Spectra*, preprint for article to be published in NGA Special Edition for Earthquake Spectra, Spring 2008.

LIST OF REFERENCES (Concluded)

15. Geocon Inc., February 14, 2003 *Consultation: Slope Stability, Reclamation ¾:1 Slopes, Hanson Aggregates Otay Ranch Pit, Hanson Otay Mesa Quarry, Chula Vista, California* (Project No. 07052-42-01).
16. Geocon Inc., October 4, 2006, *Consultation: Temporary Stockpile, Hanson Otay Mesa Quarry, Chula Vista, California* (Project No. 07741-42-01).
17. Geocon Inc., October 4, 2006, *Preliminary Geotechnical Evaluation, Otay Quarry, 2041 Heritage Road, Chula Vista, California* (Project No. G1296-42-01).
18. Geocon Inc. March 27, 2014, *Geotechnical Investigation, Otay Ranch Village 3 North and Village 4 Park Site, Chula Vista, California* (Project No. 06930-11-02).
19. Hoek, E. and J. W. Bray, 1981, *Rock Slope Engineering, Institution of Mining and Metallurgy*.
20. Jennings, C. W., 1994, *Fault Activity Map of California and Adjacent Areas*, California Geologic Data Map Series, Map No. 6.
21. Risk Company, *EZ-FRISK*, (Version 7.62) 2013.
22. Treiman, Jerome A., 1993, *The Rose Canyon Fault Zone Southern California*, California Division of Mines and Geology Publication.
23. URS, 2004, *San Diego County Multi-Jurisdictional Hazard Mitigation Plan, San Diego County, California*, dated March 15, (URS Project No. 27653042.00500).
24. U.S. Geological Survey (USGS), 2008, *Deaggregation of Seismic Hazard for PGA and 2 Periods of Spectral Acceleration*, USGS Website: <http://geohazards.usgs.gov/deaggint/2008/>.
25. USGS computer program, *Seismic Hazard Curves and Uniform Hazard Response Spectra*, <http://earthquake.usgs.gov/designmaps/us/application.php>.
26. Unpublished reports, aerial photographs and maps on file with Geocon Incorporated.
27. Walsh, Stephen L. and Demere, Thomas A., 1991, *Age and Stratigraphy of the Sweetwater and Otay Formations, San Diego County California*, In Abbott, P. L. and May, J. A., eds., 1991, *Eocene Geologic history San Diego Region, Pacific section SEPM*, Vol. 68,p. 131-148.