

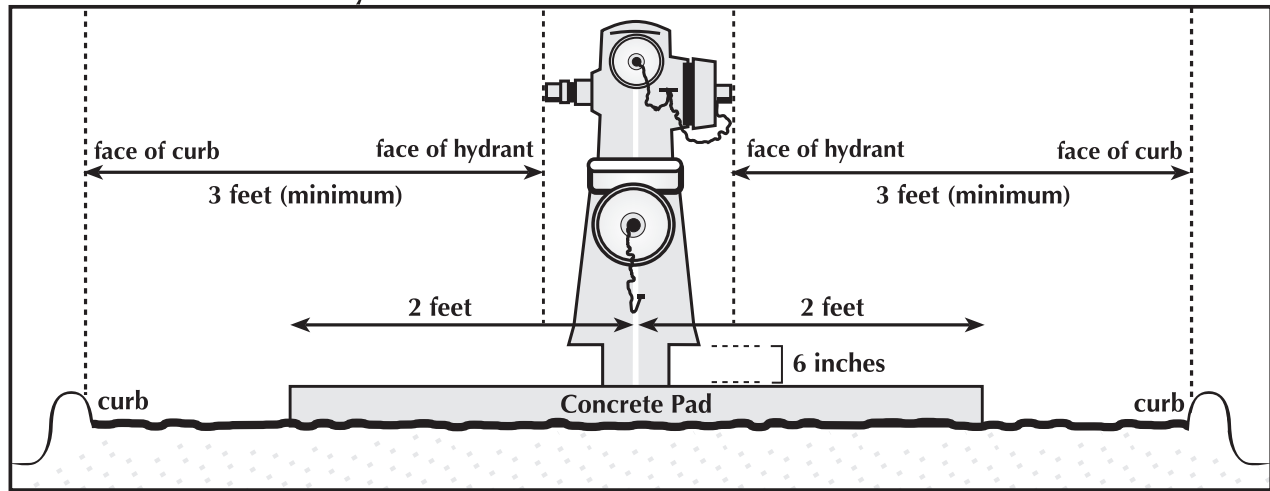

## CHULA VISTA FIRE DEPARTMENT

FIRE PREVENTION DIVISION

### Fire Hydrant Detail



SIDE VIEW

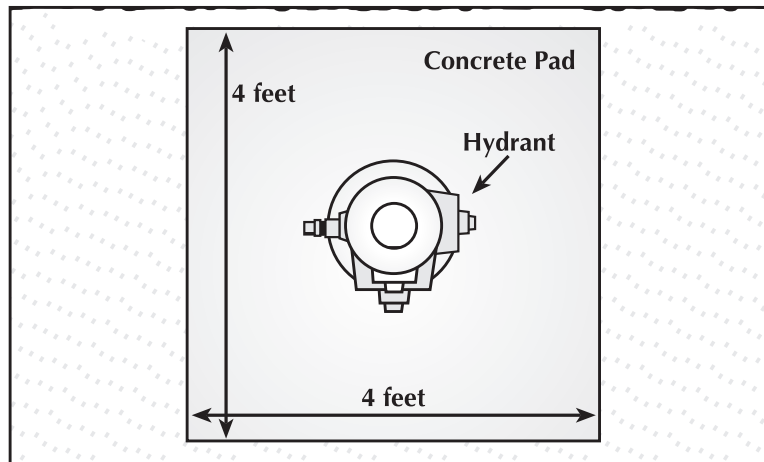

TOP VIEW

### Hydrant Specifications

1. Measurements **MUST** be exact and will be subject to a field inspection
2. Residential and commercial hydrants must have one 4 inch port and two 2 1/2 inch ports with national standard threads (NST)
3. Industrial fire hydrants must have two 4 inch port and one 2 1/2 inch port with NST
4. Painted (OSHA) yellow
5. Must have concrete pad adhering to the above specifications
6. A blue reflective marker must be in place to identify fire hydrant location
7. Concrete pad must be a minimum of 4 inches thick
8. Base of hydrant must be 6 inches from concrete pad
9. Provide 3-feet (minimum) from the face of the hydrant to the face of the curb (bollards are required if distance is not met)