

### I. Patio Cover Limitations and Requirements

- A. Patio covers, as permitted by Appendix H of the current edition of the California Residential Code (CRC), have certain limitations:
1. They are not designed or intended to be used as room additions.
  2. They cannot always be converted to complying room additions. A building permit is required for the conversion.
  3. Shall not be enclosed if openings serving as emergency or rescue openings from sleeping rooms open into the patio cover structure.
- B. CRC Appendix H specify that patio covers must meet the following requirements:
1. Are one story structures not exceed twelve feet in height.
  2. May be detached or attached to other buildings as accessories to private garages, dwellings or single units in apartment buildings.
  3. May be used only for recreational or outdoor living purposes, not as habitable rooms, carports, garages, or storage rooms.
  4. May have enclosure walls of any configuration, provided the open area of the longer wall and one additional wall is equal to at least 65 percent of the area below a minimum of 6'-8" of each wall, measured from the floor.
  5. Required openings are permitted to be enclosed with the following:
    - a. Insect screening, or
    - b. Approved translucent or transparent plastic not more than 0.125" (1/8") in thickness, or
    - c. Glass conforming to the provisions of CRC R308, or

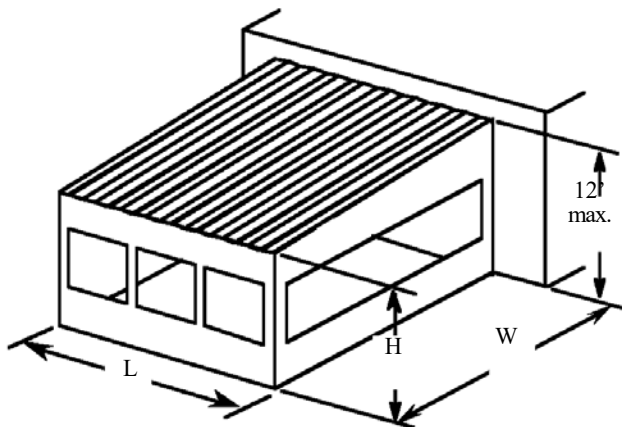

**FIGURE 1 / Patio cover with three sides open**

- d. Any combination of the foregoing.
6. Must meet structural requirements as specified in CRC AH 105.
7. Must meet the requirements of Table R302.1(1) or R302.1(2) for exterior wall construction and opening protection as required for the dwelling.

### II. Examples

The following examples are intended to show how Appendix H applies to patio enclosures:

- A. A patio cover with three sides open must have open area provided on the longer side and one other side for a total of not less than 65 percent of the area of its longer side plus one additional side as shown in Figure 1. The height of wall to be used in calculations shall be six feet eight inches (6'-8"). The remaining area may be of solid material. See Section II, Item F for computation of required open area.
- B. A patio cover with two adjacent sides open must have open area provided on the longer side and, if necessary, the shorter side for a total of not less than 65 percent of the area of the longer side plus the shorter side as shown in Figure 2. The height of wall to be used in calculations shall be six feet eight inches (6'-8"). The remaining area may be of solid material. See Section II, Item F for computation of required open area.
- C. A patio cover with two opposite sides open must have open area provided on either or both of the open sides for a total of not less than 65 percent of the area of side "L" plus side "W" as shown in Figure 3. The height of wall to be used in calculations shall be six feet eight inches (6'-8"). The remaining area may be of solid material. See Section II, Item F for computation of required open area.
- D. A patio cover with one side open must have open area provided on side "L" equal to at least 65 percent of the area of side "L" plus side "W" as shown in Figure 4. The height of wall to be used in calculations shall be six feet eight inches (6'-8"). The remaining area may be of solid material. See Section II, Item F for computation of required open area.
- E. A patio cover with one side and a portion of a second side open must have open area provided on side "L" and side "R" equal to at least 65 percent of the area of side "W" plus side "L" as shown in Figure 5. The height of wall to be used in calculations shall be six feet eight inches (6'-8"). The remaining area may be of solid material. See Section II, Item F for computation of required open area.

**FIGURE 2 / Patio cover with two adjacent sides open**

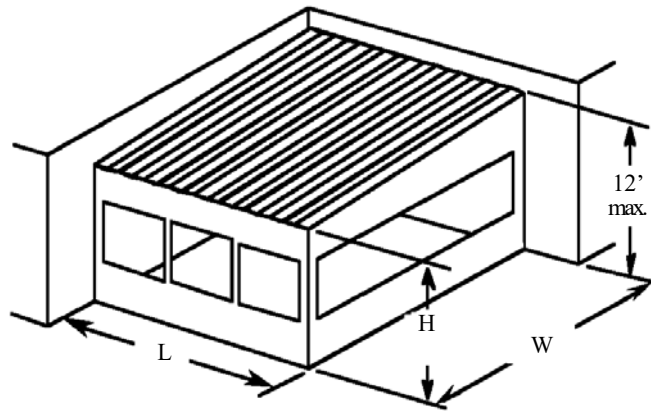

**FIGURE 3 / Patio cover with two opposite sides open**

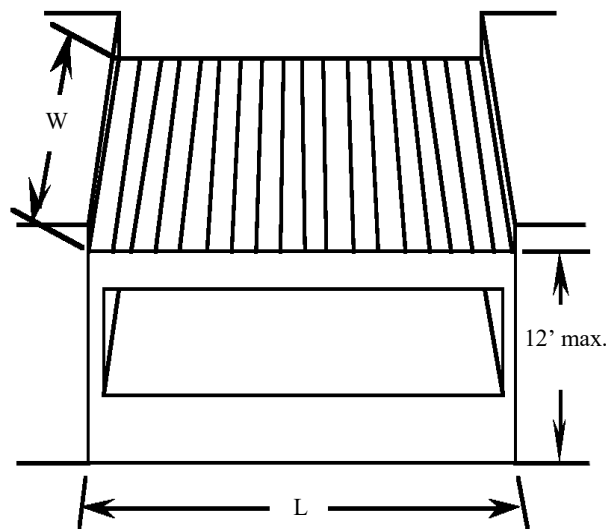

**FIGURE 4 / Patio cover with one side open**

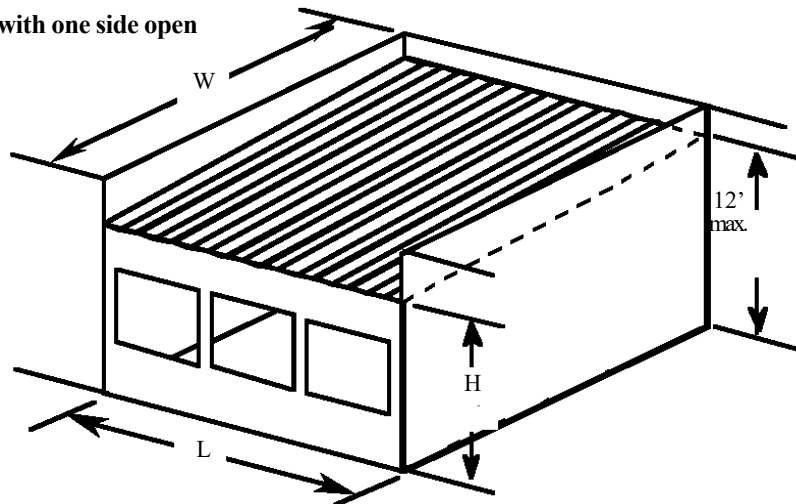

**FIGURE 5 /** Patio cover with one side and a portion of a second side open

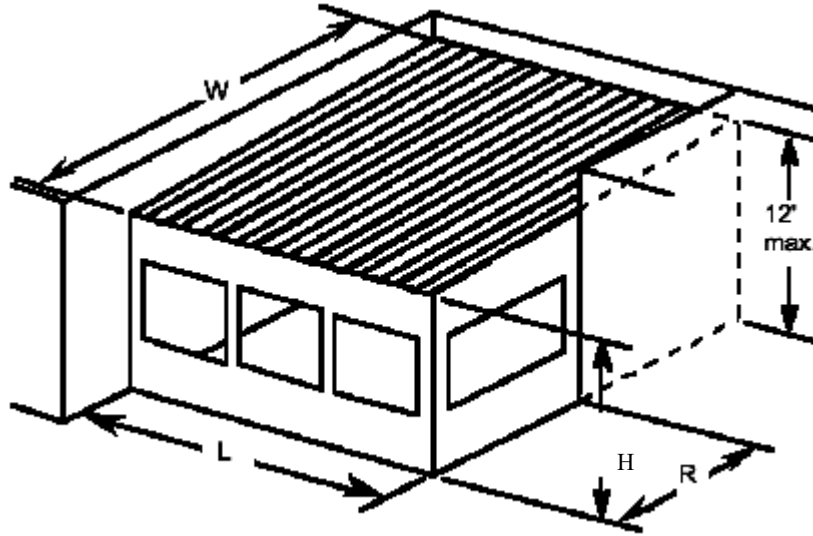

**F. Figure 6 illustrates computation of open area for a patio cover.**

Question:

Does the patio cover shown in Figure 6 have sufficient open area?

Answer:

Required open area:  
 =65% of 15' and 20' walls for a height of 6'-8"  
 (even though wall exceeds this 6'-8" minimum height)  
 =0.65 x (20' + 15') x (6.66')  
 =152 sq. ft. required

Open area of longer side:  
 = (6' x 11') + (6' x 6')  
 = 102 sq. ft.

Open area of shorter side:  
 = 6' x 14'  
 = 84 sq. ft.

Total open area provided:  
 =102 sq. ft. + 84 sq. ft.  
 =186 sq. ft.

Required open space is 152 sq. ft.; therefore, sufficient open area is provided.:

**FIGURE 6 /** Example

